

Performance of Maximum Power Point Tracking Algorithm based Photovoltaic Array and Utility Grid Interconnected System

Darshika Shukla ¹, Dr. Naveen Goel ²

¹M.Tech scholar, Electrical and Electronics Department, SSTC Bhilai, Chhattisgarh, India

²Professor, Electrical and Electronics Department, SSTC Bhilai, Chhattisgarh, India

Abstract - This paper presents modeling and simulation for the design of a hybrid micro grid system with renewable energies and methods for their control, resulting from the analysis. The photovoltaic installation includes photovoltaic panels and a DC-DC boost converter. The boost converter connected to the photovoltaic station was controlled using an additional maximum Power Point tracking and using incremental conductance algorithm (IC-MPPT A). The conversion element for boost converters is IGBT. The switching frequency of the boost transformer is 50 kHz for the photovoltaic array connected to the boost transformer. The hybrid micro grid was paired with a 1000V DC bus. A 400 V / 120 kV transformer and a 120 kV and 50 Hz AC power supply were used to create the network model. To convert DC to AC, as a topology, a full bridge inverter circuit was used and IGBT was chosen as the switching element. The phase closed loop (PLL) algorithm was used as a control so that the alternating current voltage generated at the output of the inverter is of the same phase, frequency and amplitude as the network. The system was operated under sunlight. Despite these variables, the desired results were obtained from the system.

Key Words: DC-DC Boost Converter; IC,MPPT techniques; PV array model; Three Phase Three-Level Inverter, IGBT, PLL.

1. INTRODUCTION

The increasing demand for energy particularly in developing countries like India and China and depletion of fossil fuel reserves has pushed all countries to finding alternative sources of energy. Though we are having many alternative sources of energy, solar PV and wind are the widely used energy resources [1]. A PV system consists of many components such as PV modules, mounting structure and electrical connections and means of regulating and modifying the electrical output. As we know solar cells, when exposed to solar radiation, produce DC power which has to be converted to AC power using power electronics-based converters along with control equipment's [2]. Most of the PV inverters are voltage-source inverters as they are simple have both voltage and current loops with good stability, very fast response. These are easy to implement and have inherent ability to control both voltage and current. The modeling and simulation of 100 kWp photovoltaic Power System installed and operating at G.

Narayanamma Institute of Technology & Science since March 2014. This grid-connected PV system consists of PV arrays installed on the roof-top terraces of two of the buildings in the college.

The photovoltaic panels are connected to the distribution boards of the building concerned by five 20 kW inverters. [3]-[4]. The simulation was carried out using the mathematical model for 20 kW photovoltaic panels. Two popular Maximum Power Point Tracking (MPPT) algorithms for capturing the maximum possible power under different solar irradiance conditions on the MATLAB/Simulink platform [5]. The two MPPT algorithms used viz. The (1) Perturb and Observe (P&O) and (2) Incremental Conductance (IncCond) algorithms are included in the control strategies used in the DC-DC boost converter connected between the PV array and the inverter [6]. The results of the simulation of the output power and other solar radiation variation parameters were compared with the actual power measurements made at the corresponding irradiance levels.

2. II. MATHEMATICAL MODEL OF A PV CELL

The grid-connected photovoltaic system transfers the energy generated from the photovoltaic system to the electrical grid. The block diagram of the grid-connected photovoltaic system can be represented in principle as shown in Figure 1

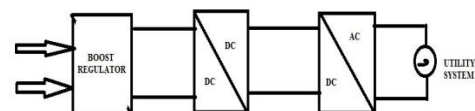

Fig 1: Block diagram of hybrid system

Photovoltaic array is a semi-conductor device that generates direct current electricity from sunlight. It is a combination of photovoltaic modules connected in series and in parallel. The energy produced by the photovoltaic panel depends on a number of parameters, such as temperature and solar radiation.

The photovoltaic array is connected to a maximum power point tracker (MPPT) to optimize the DC output power of the photovoltaic array by varying the operating voltage of the

photovoltaic array. The direct current power is then converted into alternating current by an inverter before being routed to the electricity grid.

A. PV Array

An equivalent circuit of a solar cell is shown in Figure 2[1] which can be represented by (1).

$$I = I_{ph} - I_0 \left[\exp \left(\frac{V + R_s I}{V_t a} \right) - 1 \right] - \frac{V + R_s I}{R_p} \tag{1}$$

Where:

I_{ph} = the solar-generated current.

I_0 = is the diode saturation current.

$V_t = NskT/q$ is thermal voltage of the array.

N_s = number of cells connected in series.

a = ideality constant of diode .

R_s = series-resistance.

R_p = parallel-resistance.

The current generated by the sun, I_{ph} , is linearly dependent on solar radiation and is influenced by temperature depending on the (2)[1].

$$I_{ph} = \frac{G}{G_n} [I_{phn} + K_i(T - T_n)] \tag{2}$$

where

$I_{ph,n}$ = Solar initiate current at the nominal-condition (25°C and 1000W/m²);

G = irradiance;

G_n = nominal irradiance;

T = cell temperature;

T_n = nominal cell temperature;

K_i =short-circuit current/temperature coefficient.

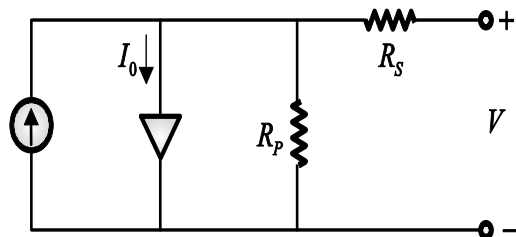

Fig 2: PV array Model

The diode imprehgnation current, I_0 which depends on temperature is given by (3)[2].

$$I_0 = N_{pp} I_{pv} - N_{pp} I_0 \left[\exp \left(\frac{V + IR_s \left(\frac{N_{ss}}{N_{pp}} \right)}{V_t a N_{ss}} \right) - 1 \right] - \frac{V + IR_s \left(\frac{N_{ss}}{N_{pp}} \right)}{R_p \left(\frac{N_{ss}}{N_{pp}} \right)} \tag{3}$$

Where:

I_0 = nominal diode saturation current.

$q=1.602*10^{-19}$ C (electron charge).

$k=1.380*10^{-23}$ J/K (Boltzmann constant).

$E_g=1.12$ eV is the band gap energy.

The nominal diode

$$I_{0,n} = I_{an} \left(\frac{T}{T_n} \right)^3 \exp \left[\frac{qE_g}{ak} \left(\frac{1}{T_n} - \frac{1}{T} \right) \right] \tag{4}$$

$$I_{o,n} = \frac{I_{sc,n}}{\left[\exp \left(\frac{V_{oc,n}}{aV_{t,n}} \right) \right] - 1}$$

Where:

$V_{oc,n}$ = nominal open-circuit voltage;

$V_{t,n}$ = nominal thermal voltage of the cell;

$I_{sc,n}$ = short-circuit current at the nominal condition (25oC and 1000W/m²).

A practical photovoltaic panel consists of several switched photovoltaic modules consisting of N_s solar cells connected in series and in parallel. Therefore, (1) with a single PV cell should be replaced with (5) to represent a PV generator. [2],[3].

3. DC-DC CONVERTER

Figure 3 below shows a boost or pulse width modulated (PWM) converter. It consists of a DC input voltage source V_g , a controlled switch S , a diode D , a boost inductor L , a filter capacitor C and a load resistor R .

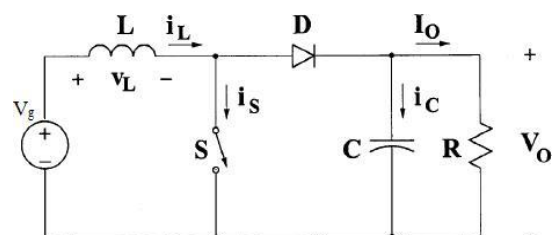

Fig 3: Circuit diagram or boost converter

From the inductor voltage balance equation we have

$$V_g(DT_s) + (V_s - V_0)(1 - D)T_s = 0$$

In practice, the photovoltaic generator is connected to the MPPT so that the photovoltaic generator can produce the maximum power it is capable of by varying the electrical operating point of the photovoltaic generator. The MPPT is basically a DC-DC converter as shown in Figure 3. The converter changes the operating voltage level of the PV array so that it can operate at V_{mp} to produce maximum power. The operating voltage level is controlled by changing the duty cycle of the inverter. A pulse-width modulation (PWM) control signal is applied to the gate of the transistor in the DC-DC converter, as shown in Figure 3. An algorithm automatically controls the generation of the PWM control signal. The Hill Climb (HC) algorithm is used to control the duty cycle of the converter. Figure 4 shows the flowchart of the HC algorithm [9]. In the proposed algorithm, the current and the voltage drawn from the photovoltaic network are measured and the power calculated. The 'slope' is the disturbance direction of the duty cycle D with values of '1' or '-1' and 'a' is the amplitude of the disturbance step. When the power increases, the direction of the disturbance of the duty cycle remains in the same direction until the MPP is reached, on the contrary when the power decreases.

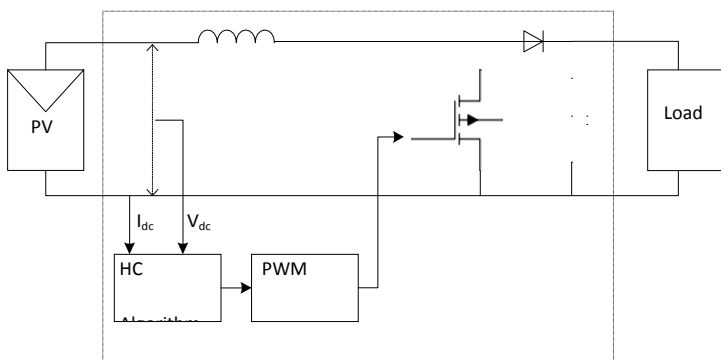

Fig 4 : Block diagram of simulation model

Many algorithms have been described in the literature to determine the maximum power of the photovoltaic system. Two of these methods, the P&O and IncCond methods, which have good convergence speed and less complexity, are used in our simulation.

4. PERTURB AND OBSERVE METHOD (P&O)

The most recommended method is the P&O method due to its simplicity and ease of implementation. In this method, the failure is in the operating voltage of the photovoltaic generator. Since the P&O algorithm cannot compare the grid terminal voltage to the actual maximum supply point voltage, the change in power is assumed to be the result of the grid terminal voltage disturbance. The output of this method exhibits oscillations which can be reduced by

minimizing the size of the disturbance. The organizational chart for P&O is shown in fig. 3, where the change in voltage at the terminals of the photovoltaic generator is responsible for the change in duty cycle.

The P&O method works by periodically increasing or decreasing the voltage or current of the photovoltaic generator by comparing the output power $P(n+1)$ with the previous value of the power $P(n)$. If the voltage disturbance at the terminals causes a power increase greater than $(dp/dv=0)$ then the disturbance must remain in the same direction or move in the opposite direction. This breakdown cycle must be repeated until maximum power is reached.

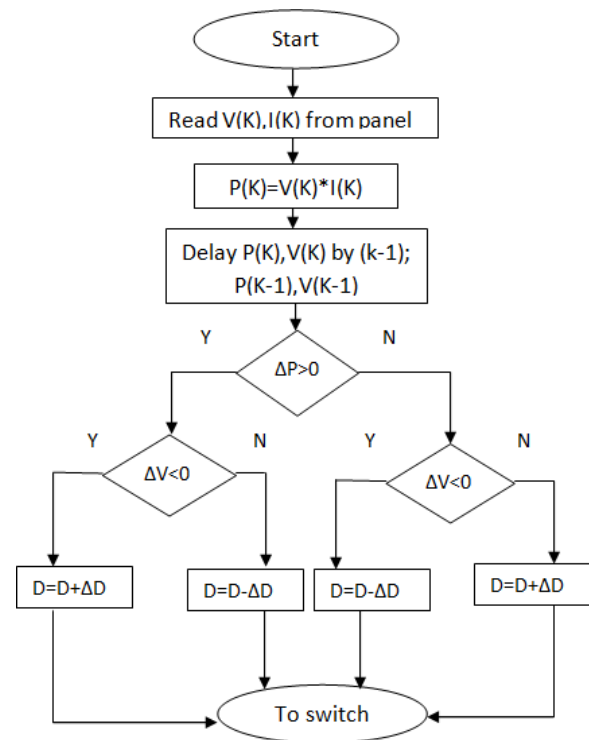

Fig.5 . Flow chart of P&O method

5. INCREMENTAL CONDUCTANCE METHOD

Usually any conventional MPPT has two independent control loops for maximum power control. The first loop contains the algorithm and the second loop contains the proportional-integral (PI) controller. This method uses incremental conduction to generate the error signal which will be zero at full power. Usually this error will not be zero, so it is up to the second control loop to make this error zero. Due to the nonlinear characteristics of the PV output and the unpredictable behavior of PI weather controllers, they do not perform well. Therefore, in this article, preference is given to the incremental conductance method, which exerts direct control. Here the duty cycle is adjusted directly from the algorithm. To compensate for the lack of PI, we allow a marginal error of 0.002. This allowable error size determines the sensitivity of the

system. The maximum power consumption condition is $(dI/dV = -I/V)$. The IncCond flowchart. The direct control method is shown in Fig. 4. According to the MPPT algorithm, the duty cycle is calculated and used as the desired duty cycle for the next step.

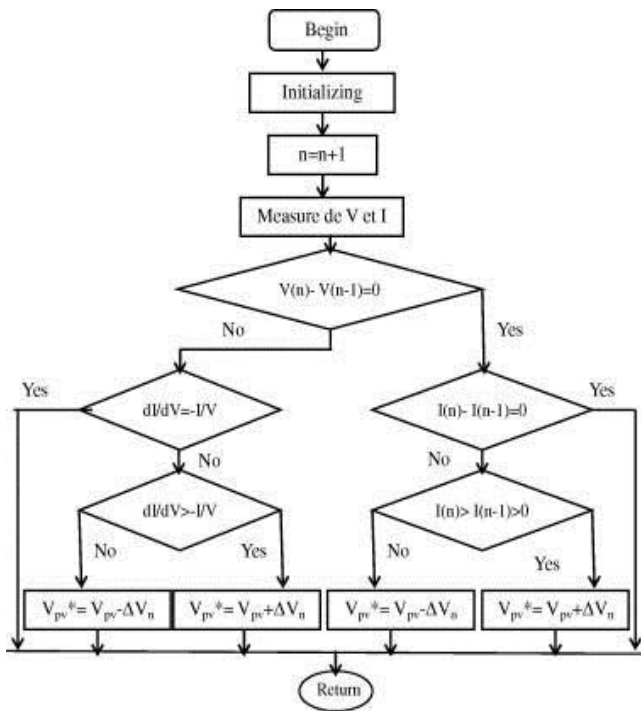

Fig 6 : Flow Chart of Incremental Conductance

6. INVERTER CONTROL

A. Three-phase three-level inverter

Here we use a three-phase three-level inverter because it provides industrial applications through adjustable frequency power. The inverter's DC power is taken from the large capacitor connected to the input terminal to suppress harmonic feedback to the source and make the DC input constant. The inverter is neutral point clamped (NPC) to have higher voltage and reduce current ripples in the waveform by increasing the number of steps.

B. Voltage source converter control

The three-phase voltage source converter regulates the DC bus voltage up to 500 volts while maintaining the power factor of one. Here, the control system uses two control loops: an outer loop to control the DC bus voltage to ± 250 volts and an inner loop to control the active current component (I_d) and the reactive current component (I_q) on the network side. The control system uses a $100 \mu s$ sampling period for the current and voltage regulators.

C. Control of grid side controller

The major functions of the grid side controller are:

- Grid synchronization
- Ensure acceptable power quality at the grid interface unit
- Control of reactive power transfer between the grid and converter
- Control of active power injected into the grid and to maintain constant DC link voltage

Here the control strategy involves two cascaded loops: The first is a fast internal current loop for maintaining sinusoidal currents and to protect against over currents and the second is an external voltages loop for balancing the power flow in the system.

SIMULINK MODEL AND RESULTS

In Simulink various PV array are present and in proposed system SunPower SPR 305 WHT-D is considered.

Parameters and its values

Parameters	Values
Number of cell per Module	5
Number of parallel string	66
Voc	64.2 V
Vmpp	54.7 V
Imp	5.96 A

In this paper modeling and simulation of a 100 kWp solar PV power plant has been done. MPPT method have been employed and it has been observed that the generation of power increases with increase in irradiance.

In this paper we present the mathematical modeling of PV and its IV characteristics by MATLAB R2020a software. This paper suggests that MPPT algorithm can be enabled with boost converter circuit so as to get better results with PV modules so as to get continuous supply with a PV grid integrated system. The overall controlling input parameter for generating power with PV module is temperature and irradiance and it has been seen that the generated PV power is inversely proportional to the temperature whereas it is directly proportional to the irradiance level measured in w/m .

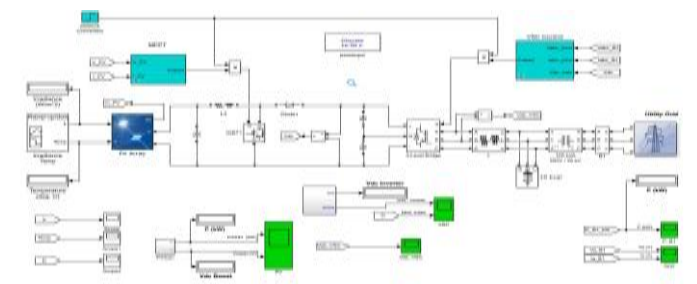

Fig 7 : Simulation Model of Hybrid Microgrid based on MPPT

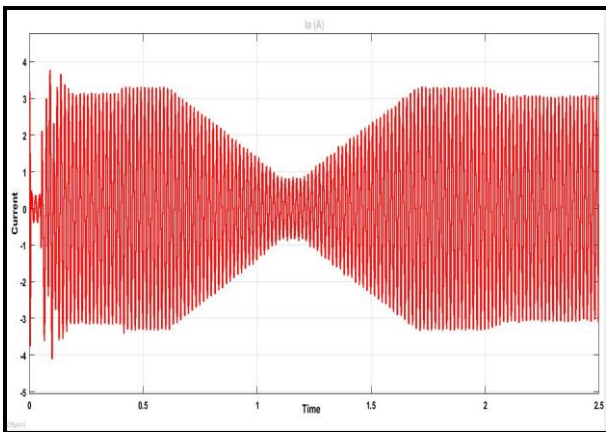

Fig 8: Current At Bus

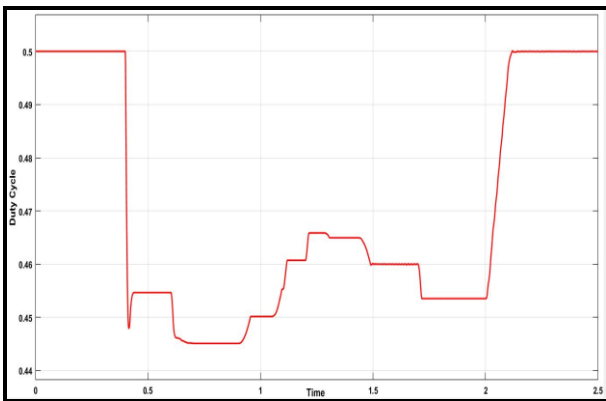

Fig 9: Duty cycle of the boost converter

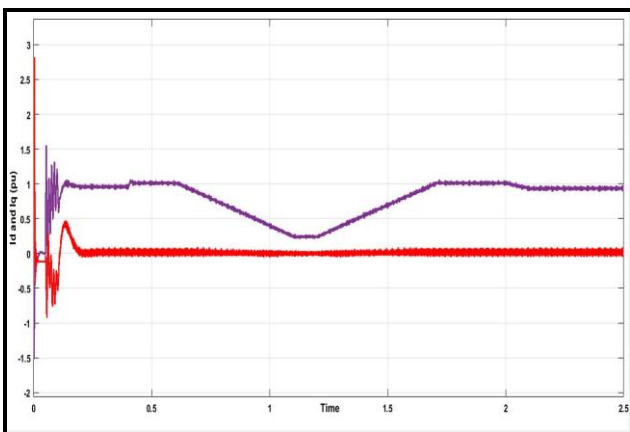

Fig 10: Id and Iq Current in pu

In figure 8 shows Current at the bus has been seen changing accordingly with the change in pattern of irradiance provided.

Fig. shows 9 the duty cycle applied to converter whose maximum value is .5. At t=.4s the applied MPPT algorithm gets enabled and starts regulating the converter's duty cycle so as to extract the maximum power from PV module.

After t=2.1s the duty cycle starts increasing and again reaches to its maximum value of .5.

Figure 10 shows the direct and quadrature current per unit values for the designed model. Id and Iq attains its maximum value of 1.5pu at time t=0.1s.

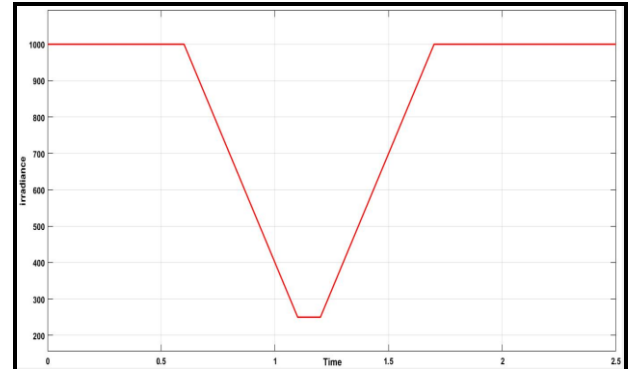

Fig 11: Irradiance of PV Array

Fig 11 shows the input of irradiance to PV modules. The irradiance level reaches a highest value of 1000w/m as shown in figure. At time t=.6sec the irradiance level start dropping and reaches to a value of 250w/m at t=1.1 s but after t=1.2s it start increasing gradually and finally attains its maximum value of 1000w/m at t=1.7s.

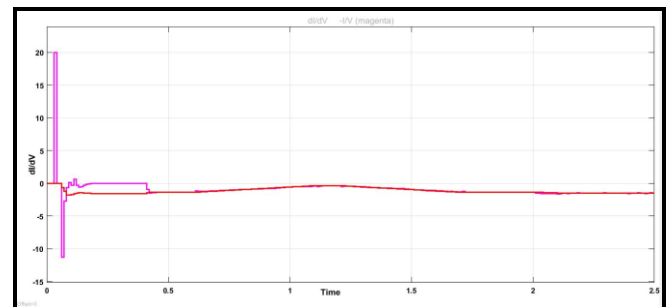

Fig 12: MPPT algorithm di/dv

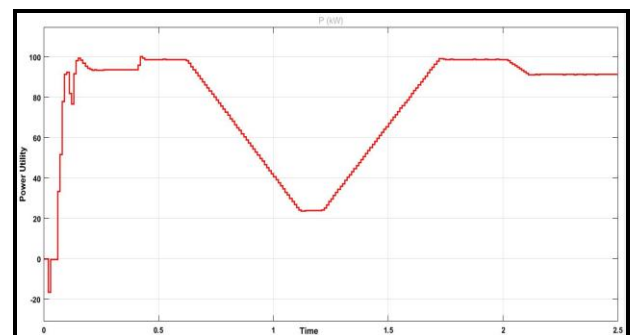

Fig 13: Power Utility

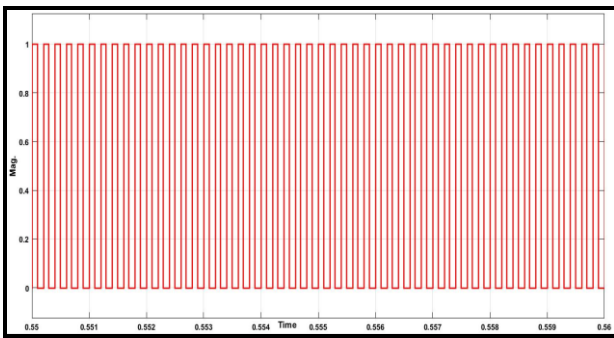

Fig 14: Pulse MPPT

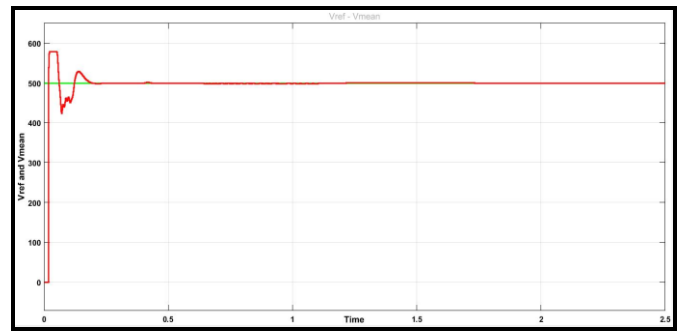

Fig 17: Vref and Vmean

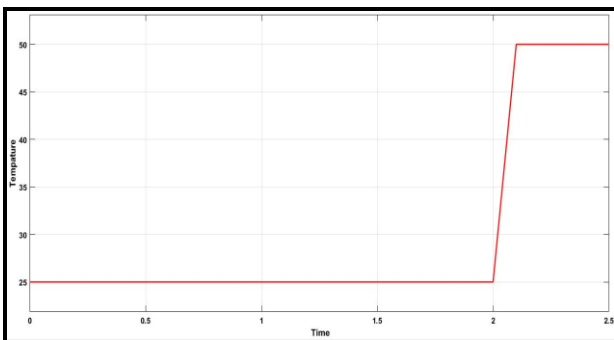

Fig 15: Temperature

Fig 15 shows the temperature variation applied at the input of the photovoltaic module. The temperature is 25°C at t=2s then reaches 50°C. In other words, we simply double the temperature to see the effect on the energy generated Curve IV.

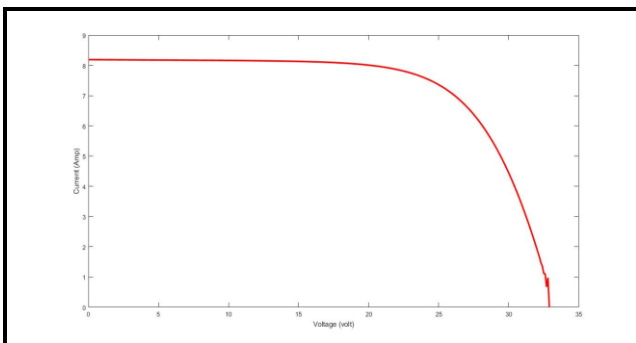

Fig 16: I-V Curve

The maximum power point of a solar cell represents the utilization of a PV modules to its full extent. Here the coordinates for maximum power point current and voltage are [7.9A, 26V]. At this operating point is tracking maximum power or in other words it can be said that it is drawing maximum power from PV Panel. The maximum power pint voltage can drift accordingly with wide range of parameters such as temperature device degradation and solar irradiance availability at location.

Mean voltage for inverter circuit is shown below in which the reference value is set at 500V whereas the mean value reaches its maximum value of 508V within fraction of seconds from 0.

7. CONCLUSION

In this work, modeling and simulation of a photovoltaic solar installation of 100 kWp. The 100 kWp system consists of five 20 kW systems connected in parallel. MPPT methods including IncCond were used to run the simulation in MATLAB/Simulink on the 100 kW system. It was observed that, as expected, the generated power increased as the irradiance increased. However, the IncCond method showed a decrease in the duty cycle when the illuminance was changed. The slight difference is due to the variation of the PV module parameters available in MATLAB. This modified MPPT algorithm is able to increase the stable and dynamic performance of the PV system. This allows us to extract maximum energy from solar radiation and ensure a stable and efficient power supply. The above results indicated that the proposed MPPT algorithm can be efficient in tracking the maximum amount of radiation and also providing the maximum energy for the PV array. Moreover, this proposed MPPT algorithm gave us maximum power at low cost and less energy loss..

REFERENCES

- [1] Antony Anila and Menon Devika, "Islanding Detection Technique of Distribution Generation System" in 2016 International Conference on Circuit, Power and Computing Technologies [ICCPCT], 978-1-5090 1277-0/16/\$31.00 ©2016 IEEE.
- [2] Rosin, H. Höimoja, T. Möller, M. Lehtla " Residential Electricity Consumption and Loads Pattern Analysis" in 978-1-4244-6981- 9/10/\$26.00 ©2010 IEEE.
- [3] "Ministry of New and Renewable Energy, Annual Report 2015-2016" Retrieved 2017-04-21. P. Rahi, Harish Kumar Thakur, and A. K. Chandel "Power

- Sector Reforms in India: A Case Study” in 978-1-4244-1762-9/08/\$25.00©02008 IEEE.
- [4] Farha Naz, Sarfaraz Shaikh, Dr. Alice Cheeran “DSP Based Controller for various Power Electronics Converters Used in Micro-Grid “ in International Journal of Recent Trends in Engineering & Research (IJRTER) Volume 02, Issue 10; October - 2016 [ISSN: 2455-1457]
- [5] Hemant Patel , Manju Gupta , Aashish Kumar Bohre ,”Mathematical Modeling and Performance Analysis of MPPT based Solar PV System “ in 2016 International Conference on Electrical Power and Energy Systems (ICEPES) Maulana Azad National Institute of Technology, Bhopal, India. Dec 14-16, 2016.
- [6] Vidhya K Viswambaran , Dr.Arfan Ghani and Dr. Erping Zhou “Modelling and Simulation of Maximum Power point Tracking Algorithms & Review of MPPT Techniques for PV Applications” in 978-1-5090-5306-3/16/\$31.00 ©2016 IEEE.
- [7] Ahmed M. Atallah, Almoataz Y. Abdelaziz, and Raihan S. Jumaah “Implementation Of Perturb And Observe Mppt Of Pv System With Direct Control Method Using Buck And Buckboost Converters ” in Emerging Trends in Electrical, Electronics & Instrumentation Engineering: An international Journal (EEIEJ), Vol. 1, No. 1, February 2014.
- [8] Dr. Rachana Garg, Dr. Alka Singh, Shikha Gupta “PV Cell Models and Dynamic Simulation of MPPT Trackers in MATLAB” in 2014 International Conference on Computing for Sustainable Global Development (INDIACom) ,978-93-80544-12-0/14/\$31.00 c 2014 IEEE.
- [9] William Christopher and Dr.R.Ramesh , “Comparative Study of P&O and InC MPPT Algorithms” American Journal of Engineering Research (AJER) e-ISSN : 2320-0847 p-ISSN : 2320-0936 Volume-02, Issue-12, pp-402-408.
- [10] Robert L.Steigerwald, “Power Electronic Converter Technology”, in Proceedings of The Ieee, Vol. 89, No. 6, June 2001, Publisher Item Identifier S 0018-9219(01)04105-6.
- [11] Jun Qi, Youbing Zhang*, Yi Chen “Modeling and maximum power point tracking (MPPT) method for PV array under partial shade conditions “ in journal of College o Information Engineering, China. Available [online] Renewable Energy journal homepage: www.elsevier.com/locate/renene ,2013 Elsevier Ltd.
- [12] N.Femia, G.Petrone, G. Spagnuolo, M. Vitelli, "Optimizing sampling rate of P&O MPPT technique," in Proceeding of IEEE PESC, pp 1945- 1949,2004. "Ministry of New and Renewable Energy, Annual Report 2015-2016".Retrieved 2017-04-21 SPR-305E-WHT-D by SunPower data sheet [online] Available:http://www.solarhub.com/solarhub_products/16980-SPR-305E-WHT- D-SunPower.