

Automatic Medical Waste Segregation Machine

Mohammed Ziyad T. K¹, Dr. George Rapheal²

¹ PG Student, Industrial Automation and Robotics, Jyothi Engineering College Thrissur, Kerala, India.

² Associate Professor, Mechanical Engineering, Jyothi Engineering College Thrissur, Kerala, India.

Abstract - A significant amount of potentially hazardous wastes is produced by hospitals. because it is important for everyone who works in hospitals to be aware of the correct procedures for getting rid of toxic waste. In the absence of such measures, the wastes may cause issues for the medical staff and/or the general population by increasing their susceptibility to infectious diseases like AIDS, typhoid, boils, and Hepatitis A or B. The main goal of this project is to develop a creative new method for segregating municipal waste in India, where rag pickers currently handle the majority of waste separation. They mostly sort all of the trash by hand, including dangerous hospital waste and canisters with dangerous heavy metals. As a result, it causes harmful chronic health impacts like tuberculosis, cancer, and heavy metal poisoning, which may lower one's quality of life, shorten one's lifespan, and have an impact on future generations of children born to such affected parents.

Keywords – Waste Management, Arduino Uno, Dangerous Waste, IR Sensor, Metal Detector.

1. INTRODUCTION

A significant amount of potentially hazardous wastes is produced by hospitals. Everyone The main goal of this project is to develop a creative new method for segregating municipal waste in India, where rag pickers currently handle the majority of waste separation. They mostly sort all of the trash by hand, including dangerous hospital waste and canisters with dangerous heavy metals. As a result, it causes harmful chronic health impacts like tuberculosis, cancer, and heavy metal poisoning, which may lower one's quality of life, shorten one's lifespan, and have an impact on future generations of children born to such affected parents.



Fig 1: Waste Dump Yard

We rely on sensors to determine how to separate the plastic waste from the wet metallic waste. We suggest installing an "AUTOMATIC WASTE SEGREGATOR" at the hospital and clinic to address this issue. who works in hospitals, from the doctor to the janitor, must be aware of the correct procedures for disposing of hazardous wastes because there are so many individuals doing a variety of jobs there. In the absence of such measures, the wastes may cause issues for the medical staff and the general population by increasing their susceptibility to infectious diseases like AIDS, typhoid, boils, and Hepatitis A or B.

1.1 Existing System



Fig 2: Existing System

Currently, wastes are disposed of in a simple bin with no segregation, which leaves them vulnerable to contamination from blood syringes, sponges, and other wastes that are cleaned on a weekly or monthly basis without any safety precautions. These conditions can result in physical infection and some fatal diseases.

1.2 Limitations of Existing System

- The current method could result in dangerous diseases.
- spreads viral illnesses with medical staff serving as the carriers.

1.3 Aim and Objectives

We are using three different types of sensors, infrared sensor, wet sensor, and metal detector to separate the waste

into metallic, wet, and other waste in order to find a solution for the messy, unhygienic way of disposal and put them on the right path. The programming for these sensors is done in Arduino.

The objectives of this project are:

We are using sensor-based trash detection in this proposed system.

- Consequently, our concept is to create a garbage segregator that can recognize the type of waste and automatically sort it into the appropriate receptacles.
- By implementing this project at the hospital or medical level, physical labour and trash disposal costs will be reduced.
- To measure the many parameters of the waste and bins, we worked with sensors like rain sensors, proximity sensors, and ultrasonic sensors.

1.4 Scope

This type of segregator is used in small clinics and hospitals where there is a great deal of waste production and improper disposal, in order to maintain hygienic conditions and prevent the spread of illness.

2. LITERATURE SURVEY

According to Amutha, there is no mechanism in place for households to separate waste into categories like dry, wet, and metallic wastes. At the household level, an Automated Waste Segregator (AWS) can be utilized to separate waste so that it can be processed right away. Depending on the threshold values chosen, the AWS uses capacitive sensors to distinguish between wet and dry waste and inductive sensors to recognize metallic objects. Ceramic, on the other hand, cannot be classified into dry waste because it has a greater relative dielectric constant than the other dry wastes that are. By improving precision and overall effectiveness.

The system's drawbacks include the fact that it can only separate one sort of waste at a time, with precedence given to metal, wet, and dry waste. Thus, a mixed form of garbage can be separated using buffer spaces. Since metal objects can be sensed quickly, it is possible to achieve better results by placing the entire sensing module along a single platform where the object is steady.

As said by Aleena VJ The trash segregator, as its name implies, divides garbage into three main categories: plastic, organic waste, and metallic waste. The suggested system would have the ability to handle and monitor the collection of solid waste in general. To control the flow of garbage onto the conveyor, an open and shut mechanism is included in the

inlet portion. The metallic trash is located using an inductive proximity sensor. Waste is separated into dry and wet categories using a blower mechanism. Arduino Uno regulates the conveyor belt's timing and motion. This prevents any segment from operating continuously or needlessly.

For Vijay, a mechanical device can be used to separate wet and dry garbage into different containers; in this case, sensors can be utilized to distinguish between the two types of waste. An IR sensor can be used to identify the presence of any waste, wet or dry, and in the following step, a moisture sensor can be used to detect wet waste. In this process, the motor rotates in the direction of the dry waste container if only infrared detection of the waste is made; otherwise, it moves to the wet container. Both of these containers have ultrasonic sensors built into the top that are used to measure distance. This allows for the measurement of the waste contained in the containers.

According to Rashmi M. Kittali, even PLC can be used with AWS It benefits from less labour, better precision, and quicker waste management. Additionally, employment in dangerous environments is avoided. In the future, this operation could be completed by using a robotic arm to collect and place recyclable goods. By mounting limit sensors at the top of each bin, the bins can be unloaded. Based on the results of the aforementioned survey, we will develop an AWS utilizing an Arduino UNO with a feedback system that will use an ultrasonic distance measure sensor. As soon as garbage reaches the sensor level that is attached in the bin, the system will turn off.

2.1 Conclusion Based on Literature Review

We can sort the medical waste into metallic waste, wet waste, and metal waste by employing an infrared sensor, a wet sensor, and a metal detector. Segregation can be accomplished through programming in the corresponding arduino.

3. MATERIALS AND COMPONENTS DESCRIPTION

3.1 HARDWARE COMPONENTS

3.1.1 UNO Arduino

A widely used open source microcontroller board powered by the ATmega 328P is called the Arduino Uno. This board was created by the hardware business Arduino.cc, which has its headquarters in Italy. A number of digital and analogue I/O data pins on this board are utilized to connect it to other electrical parts. Six analogue and fourteen digital pins make up the Arduino Uno.

The Arduino IDE (Integrated Development Environment), which supports embedded C, can be used to programme this board. The board's back end is built using Java. The code for

Uno can be uploaded onto the board using the USB connection. By attaching a laptop, PC, or other device to this post, the board can also be powered. It comes with a DC input power jack in addition to a USB port. The Arduino board can alternatively be powered by a 9V external battery.

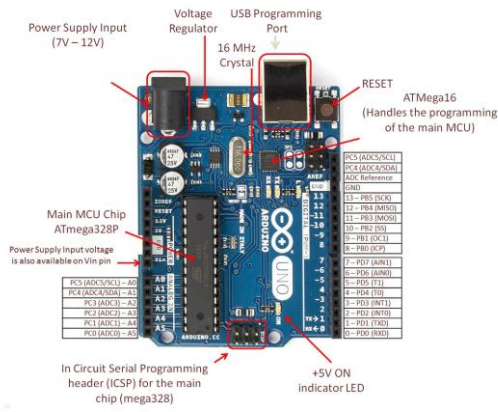

Fig 3: Arduino Uno

UART TTL (5V) serial communication is provided by the ATmega328 and is available on digital pins 0 (RX) and 1. (TX). The board's ATmega16U2 transmits this serial communication over USB and presents a virtual COM port to computer applications. There are innumerable benefits to using an Arduino over an 8051 or another micro-controller from the 8051 family. In contrast to the 8051, the Arduino has built-in ADC and DAC. Arduino may be programmed using an IDE that supports C programming, making it easier to programme than an 8051, which requires assembly language programming.

Technical Specifications:

1. Operating Voltage: 5V
2. Input Voltage: 7-20V
3. DC current per I/O pin: 20 mA
4. Flash Memory: 32 KB
5. Clock Frequency: 16 MHz.
6. No. of digital pins: 14
7. No. of analog pins: 6

3.1.2 I R SENSORS

One of the most widely used sensors in the world of electronics is the infrared (IR) sensor, which has a wide range of uses in both household and commercial settings. A sensor module called an IR module has an IR transmitter and a receiver. The obstacle detection range of this module is 5 cm, however it can be extended by 15 cm. The operating voltage is 5 volts. The heat of an object and any nearby motion can both be picked up by an IR sensor. The operation

of an IR module is rather simple. Considering that the module has a transmitter and a receiver. If there is an obstruction in the way of the IR transmitter's route once it is powered up, it begins to transmit continuous IR waves.

Technical Specifications:

1. Operating Voltage: 5V
2. Minimum Distance: 2-5 cms
3. Maximum Distance: 10-15 cms

Circuit Description: The circuit of an infrared sensor contains the following components-

1. LM358 IC two IR transmitter and receiver pair.
2. Resistors in the kilo ohms' range.
3. Variable resistor.

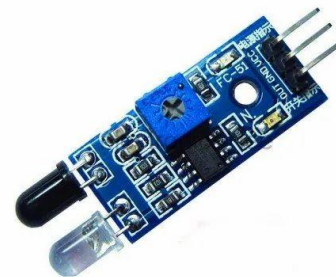

Fig 4: IR Sensor

3.1.3 METAL DETECTOR



Fig 5: Inductive Proximity Sensor

A non-contact electronic proximity sensor called an inductive proximity sensor is used to find metal. The metal being detected totally determines the sensor's sensing range.

The coil and oscillator that generate an electromagnetic field around the sensing range are the foundation of their operation. The amplitude of the oscillation is dampened by the presence of any metallic substance within the detecting range.

Technical Specifications:

1. Operating Voltage: 5V
2. Sensing Range (In case of ferrous waste): 5-3 cms
3. Sensing Range (Absence of ferrous waste): 1-1.5 cms

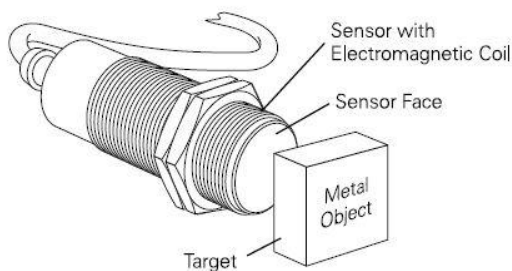

Fig 6: Block Diagram of Inductive Proximity Sensor

3.1.4 WET SENSOR

This sensor is used to determine how much moisture is present in a given substance, as its name suggests. These sensors indirectly employ the volumetric water content by utilizing other characteristics like electrical resistance and dielectric constant. In most situations, the sensor produces a voltage proportionate to the dielectric permittivity and hence determines the material's moisture content.



Fig 7: Wet Sensor

3.1.5 SERVO MOTORS

A servo motor is a rotary actuator that allows for precise control of angular position. It comprises of a motor

connected to a position feedback sensor. It also requires a servo drive to complete the system.



Fig 8: Servo Motor

3.1.6 ADC Converter

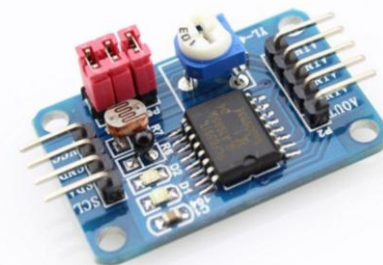

Fig 9: ADC Converter

Microprocessor-controlled circuits, Arduinos, Raspberry Pis, and other similar digital logic circuits may connect with the outside world thanks to analogue-to-digital converters, or ADCs. Many digital systems interact with their surroundings by detecting the analogue signals from such transducers because in the actual world, analogue signals have continuously changing values that come from numerous sources and sensors that can monitor sound, light, temperature, or movement.

For the PCF8591 IC, this is a breakout board or prototype board. This low-power, single-supply 8-bit CMOS data acquisition device has a serial I2C bus interface, four analogue inputs, one analogue output, and is single-chip. Up to eight devices linked to the I2C bus can be used without additional hardware thanks to the utilization of the three address pins A0, A1, and A2.

4. WORKING

4.1 Block Diagram

when we plugged in the adaptor power is delivered to the entire system The program which we are done in the c++ is being uploaded to the arduino. The programming is done like whenever the wet sensor detect the wet object it passes the information correspondingly .The servo 1 works so the opening the collecting trash is opened .waste fallen to the

bin, After delay of 1 sec the servo motor returns back so trash closes Similarly If metallic waste enters ,if it detect the corresponding the servo 2 rotates an angle of 100 degree, servo 1 opens , waste fallen to the second bin, after 1 sec delay it will return back When plastic object or any other kind of waste is being detected, the servo motor 2 rotates an angle of 180 degree, similarly the servo 1 opens and waste is fallen to the third bin after 1 sec delay servo 1 return back.

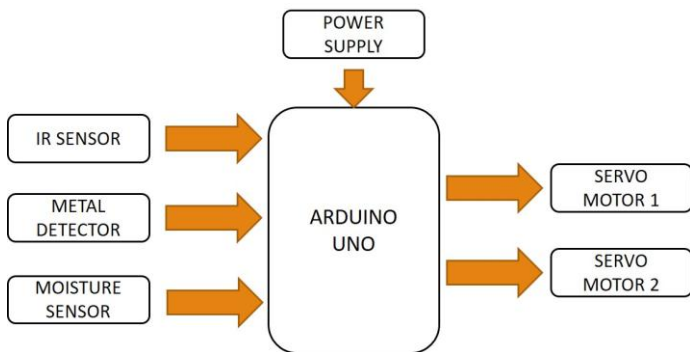

Fig 10: Block Diagram

As initially we put a wet cloth similar as to the blood coated sponge at the moment the wet sensor detects the wetness and the top open and the waste fallen to the wet bin and next we Put a needle as representing metal waste then the sensor detect that and the second servomotor rotates an angle of 100 degree and the waste fallen to the bin after a delay of 1 sec the bin closes and the servomotor 2 returns back and next we put a plastic syringe when the IR sensor detect that the servo motor 2 turns an angle of 180 degree and the third bin reach out there and the waste fallen and bin back to normal position.

4.2 Circuit Diagram

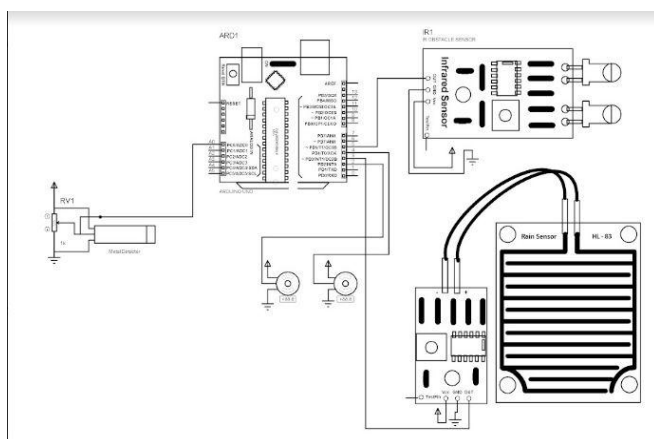

Fig 11: Circuit Diagram

This is the prototype's circuit schematic. Here, the microcontroller of the Arduino Uno is utilized to link input sensors such as the IR sensor, Rain Sensor, and Metal Detector Sensor. The metal detector's positive terminal is connected

to pin A0 on the Arduino, and the other terminal is grounded. The microcontroller's digital pins D2 and D4 are connected to the two servo motors. GND is connected to GND, and the out-of-IR sensor is attached to the Arduino's D5 pin. The ADC converter is connected to the rain sensor, and the output of the ADC is connected to the Arduino's D3 pin. On the above figure, the circuit connections are illustrated.

5. EXPERIMENTAL SETUP

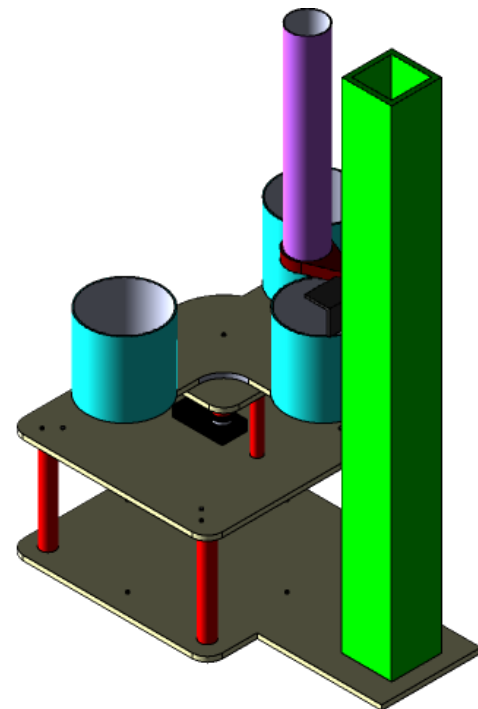

Fig 12: 3D Model

Arduino Uno has the major role in our system we have programmed accordingly We have a metal detector IR sensor and a moisture sensor connected to the Arduino board Where IR and moisture sensor are connected on the digital pin The moisture sensor is being attached with servo motor 1 and work as an opening of the slot on collector trash an ADC is connected along with wet sensor to get the output signal in dc form.

A metal detector is connected to the analog pin The two servo motors are connected to the digital side carrying a major role in the selection of the corresponding waste bin and the rest will function to support for opening and closing top We have three separate waste bin which are used to segregate wet, metal and other waste correspondingly which are connected over servomotor.

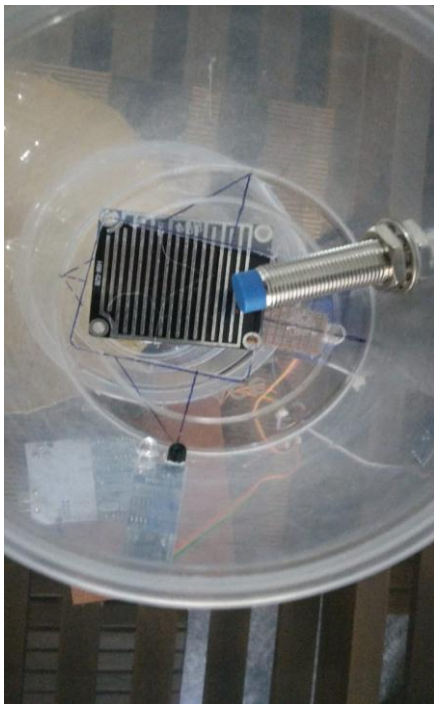

Fig 13: Metal sensor and Wet sensor are attached



Fig 14: IR sensor is attached

We have a ADC attached corresponding to the metal detector where it produces analogue signal which have to be converted in to digital signal inside the UNO board and we are using external power source instead of batteries because our servo motor 2 which is used to rotate the dust bin requires high voltage. so by the help of adapter plugged in

can serve the power required as the moisture sensor is not good enough to supply the out we are providing Pulse width modulation We have a main collecting trash with an opening controlled by servo motor for initial collection of waste.



Fig 15: Final Setup Model

6. RESULT AND DISCUSSION

As we expected the segregation take place normally without any failure the three kind of segregation expect metal detection goes very smoothly for detecting metal the sensor should be more accurate and it should have a high range width than existing one.

6.1 Advantages and Disadvantages

Advantages

1. As much of our expectation our system separates the waste materials according to wet metal and other waste instantly.
2. our system is a portable system.
3. Initial cost is very less.
4. Not a space consuming.

Disadvantage

1. Large bundle of wastes at a single moment will be complicated.
2. If there is any power loss system will not work.

6.2 Future Scope

- Every project is always having scope for improvement, here we are separating waste when they disposed simultaneously. The waste segregator can be improvised to include the separation of multiple wastes at a time.
- More compactable mechanical design can also found.
- Providing a conveyor belt at beginning can increase the sorting capability.

7. CONCLUSION

The trash segregator divides the garbage into three main categories: plastic, metallic, and moist. The suggested system would have the ability to handle and monitor the collection of solid waste in general. Metal detectors are used to identify metallic waste, and the input part is equipped with an open and close mechanism to control the flow of those detectors. To detect moisture waste and other types of trash, wet sensor and IR sensors are employed. The deployment of this system at a local level, such as societies, clinics, and other locations, can lessen the load on the local authorities. The rapid detection and functioning of sensors and the associated segregation by the system was expected. The automatic trash segregator is a modest first step toward creating a productive and affordable waste collection system that requires little to no human involvement and poses no threat to human life.

REFERENCE

- [1] Sinthiya, Nusrat Jahan, Tanvir Ahmed Chowdhury, and A. K. M. Haque. "Artificial Intelligence Based Smart Waste Management—A Systematic Review." *Computational Intelligence Techniques for Green Smart Cities* (2022): 67-92.
- [2] Batra, Deepika, and N. K. Totala. "Factors Influencing Investors' Awareness and Perception towards the Hedge Funds in India: An Innovative Approach for Empirical Study." *RESEARCH JOURNEY* 88 (2019): 135.
- [3] Devi, RS Sandhya, V. R. Vijaykumar, and M. Muthumeena. "Waste segregation using deep learning algorithm." *International Journal of Innovative Technology and Exploring Engineering* 8, no. 02 (2018).
- [4] Harika, K., V. Rajasekhar Muneerunnisa, P. Venkateswara Rao, and L. J. N. SreeLakshmi. "IoT based smart garbage monitoring and alert system using arduino UNO." *Int. J. Innov. Res. Comput. Commun. Eng* 6, no. 2 (2018).
- [5] Saha, Himadri Nath, Supratim Auddy, Subrata Pal, Shubham Kumar, Shivesh Pandey, Rakhee Singh, Amrendra Kumar Singh, Swarnadeep Banerjee, Debmalya Ghosh, and Sanhita Saha. "Waste management using internet of things (iot)." In 2017 8th annual industrial automation and electromechanical engineering conference (IEMECON), pp. 359-363. IEEE, 2017.
- [6] Kumar, BR Santhosh, N. Varalakshmi, Soundarya S. Lokeshwari, K. Rohit, and D. N. Sahana. "Eco-friendly IOT based waste segregation and management." In 2017 International Conference on Electrical, Electronics, Communication, Computer, and Optimization Techniques (ICEECCOT), pp. 297-299. IEEE, 2017.
- [7] Sejera, Marloun, Joseph Bryan Ibarra, Anrol Sarah Canare, Lyra Escano, Dianne Claudinne Mapanoo, and John Phillip Suaviso. "Standalone frequency based automated trash bin and segregator of plastic bottles and tin cans." In 2016 IEEE Region 10 Conference (TENCON), pp. 2370-2372. IEEE, 2016.
- [8] VJ, Aleena, Kavya Balakrishnan, T. B. Rosmi, K. Swathy Krishna, S. Sreejith, and T. D. Subha. "Automatic waste segregator and monitoring system." *Journal of Microcontroller Engineering and Applications* 3, no. 2 (2016): 1-7.
- [9] Chandramohan, Amrutha, Joyal Mendonca, Nikhil Ravi Shankar, Nikhil U. Baheti, Nitin Kumar Krishnan, and M. S. Suma. "Automated waste segregator." In 2014 Texas Instruments India Educators' Conference (TIIEC), pp. 1-6. IEEE, 2014.
- [10] Rajkamal, R., V. Anitha, P. Gomathi Nayaki, K. Ramya, and E. Kayalvizhi. "A novel approach for waste segregation at source level for effective generation of electricity—GREENBIN." In 2014 International Conference on Science Engineering and Management Research (ICSEMR), pp. 1-4. IEEE, 2014.