

# FEEDER PROTECTION SYSTEM FROM EARTH FAULT, SHORT CIRCUIT AND OVERLOAD FAULTS

Sandesh Kulye<sup>1</sup>, Gaurav Shelke<sup>2</sup>, Praful shinde<sup>3</sup>, Saishyam Nirgun<sup>4</sup>, Ganesh Mhatre<sup>5</sup>

<sup>1,2,3,4</sup> Department of Electronics and Electrical Engineering, NHITM, Thane, Maharashtra

<sup>5</sup> Professor, Dept. Electrical Engineering, New Horizon Institute of Technology, Maharashtra, India

\*\*\*

**Abstract** - The aim of this project to protect the bus bar from an overload, a short circuit and Earth fault condition. In the power system the Over load condition occurs because of over current flowing in the circuit due to an unbalance of a load. The primary winding of the distribution transformer or any other transformer is designed to operate at certain specific current if that current flowing through that instrument is more than the rated current, then immediately the system may burn or get damaged. Thus, we are going to protect the bus bar from over load condition. This project work is on protection from over current and over load and to trip the circuit, when over load is occurred relay will trip the complete circuit and buzzer will on to indicate over load. It will be indicated also with the help of led. Under healthy condition the resultant current is equal to zero. In 3 phase system whenever the unbalance in current is occur the resultant current is not equal to zero. If this value exceeds the predefined value indicated on the relay, then the relay actuates and trips the complete circuit.

**Key Words:** Feeder Protection, Arduino, ACS712 Current Sensor, Relays

## 1. INTRODUCTION

In electric power system, an automatic short circuit and overload protection system is a circuit breaker equipped with a mechanism that will automatically close the breaker contacts after it has been opened due to a fault. Automatic protection systems for faults and overload are used in coordinated protection schemes for overhead transmission line power distribution circuits. These circuits are prone to temporary faults such as short circuit or overload. With traditional circuit breaker or fuse, a transient fault would open the contacts of breaker or blow the fuse, which will result in disabling the line until a technician could manually close the circuit breaker or replace the fuse. But an automatic short circuit and overload protection system will make several attempts to re-energize the line. If the momentary fault has cleared, the automatic protection system will keep the circuit breaker closed and normal operation of the power line will resume.

Protection of the power system is most important point while designing electrical power system. We need to protect these electrical power system components from

any kind of fault and other conditions like overload. This increases the life cycle of the components and also removes unnecessary expenses in frequent replacement of outdated components. It gives assurance of continuous power supply in order to help the needs of the overgrowing industry. This project therefore pursues a automatic system based on micro-controller that will smartly monitors the faults and reminds a safety measures in order to protect the feeder in the event of power overloading, short circuit and earth faults.

## 1.1 Objective

The main objective of this project is to design and implement a system with the support of Arduino and other peripheral devices to protect feeders from earth faults and overloading. To achieve this the following steps to be done. i) Design and build over current relay using Arduino and current sensor. ii) Development of program to convert the analogue sensor output to equivalent digital form within the (Arduino). iii) Development of LCD program in order to display the sensed levels by sensors and enhancement of warning (audio and visual) relay control system program. iv) Automatic reclosing of relay and relay co-ordination for earth fault relay.

## 1.2 Literature Review

An electric power system is a network deployed to supply, transfer, and use electric power with both reliability and economy. To ensure the highest returns on the large investment in the equipment like transformers feeders, which helps to make up the power system and to keep the users satisfied with dependable service, the entire system must be kept in operation continuously without major failures. The main idea is to restrict the disturbances during such failures to a limited area and continue supplying power in the balance areas. Equipment like relays is normally installed to find out such kind of faults. Which can perhaps happen in various sections of a power system, and to separate faulty sections so that the interruption is kept in a limited area in the total power system. A protecting relay is the device; whose work is to give instruction to detach a faulty part of the system. This action guarantees that the remaining system is still supplied with power also it protects the system from

further damage due to the any kind of fault. Hence, use of protective device is very important in the electrical systems, which are expected to generate, transmit and distribute power with least interruptions and fast restoration time. It can be well known that use of protective equipment is very vital to minimize the effects of faults, which otherwise can destroy the whole system.

### 1.3 Architecture

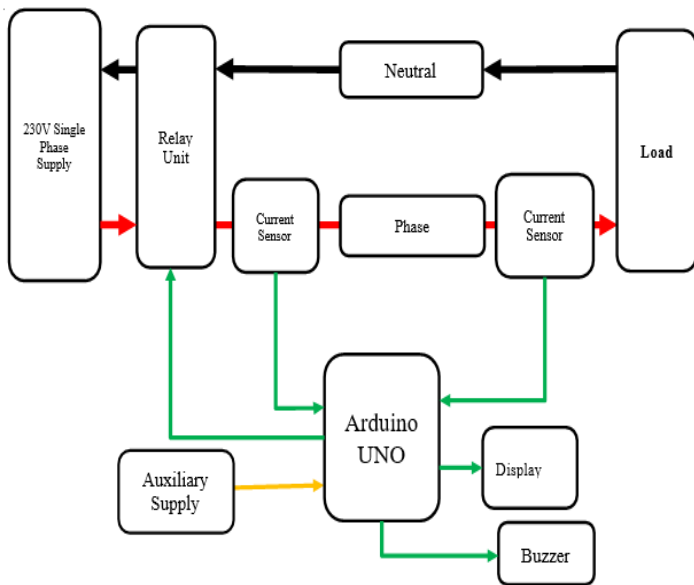

Fig - 1: Block Diagram

### 1.4 Block Diagram Description

Single Phase Feeder Supply is the input supply from the public utility where the device will be energized (230V). Relay is used to isolate feeder from supply. CT1 and CT2 it's the zone of protection for feeder from internal fault. This is the differential protection for the system. Neutral and Phase are the aluminum bars which carries the single phase 230 v supply. Arduino is the controller used in this project. It compares the currents value with the preset value. Buzzer is used for Sound Indication in only Abnormal Condition. Display unit shows the current value in normal and abnormal condition.

## 2. EXPERIMENTATION

We are demonstrating this project on a single-phase circuit. MCB is connected in phase circuit at starting, which is not an actual part of this circuit but used for protection purpose. Then phase and neutral wires are connected to the common terminal of relays, which is assembled on the control unit. Another connection taking from NC contact of the relay. Phase and neutral connected to their respective feeders, which is nothing

but aluminum rods. Current sensor ACS712-5A is connected in series in phase circuit at both ends of phase feeder. Phase and neutral connected to the terminal, from which we can take outlet for the load. For load, three 100w Incandescent lamps are arranged in a parallel manner with a separate switch connected for each lamp. By making on and of this lamp we can vary the load on this circuit. One socket- outlet is made for extra load connection.

Arduino UNO R3 is used for controlling all the operations in this project. 16\*2 LCD display connected Arduino, through I2C breakout board. Analogue pin A4, A5, 5v and GND pins connected to this I2C. Pin A0 and A1 are receiving an output signal from current sensor 1 and 2 respectively. Digital pin 9 goes high when any abnormal condition arrives in the feeder. This pin connected to the transistor's Base, collector of the transistor is connected to another 9V battery, an emitter connected to the positive terminal of both Relays. We are used NPN transistor BC637 in this circuit. The ground terminal of relays commonly connected to GND of Arduino. 9v battery is used for providing sufficient power to the relay coil. A negative terminal of the battery and GND pins are connected for proper operation. Green LED is connected to digital pin 8, which show normal operation condition. Buzzer and Red LED is connected to pin 7, goes high when any abnormal condition on feeder sense by Arduino.

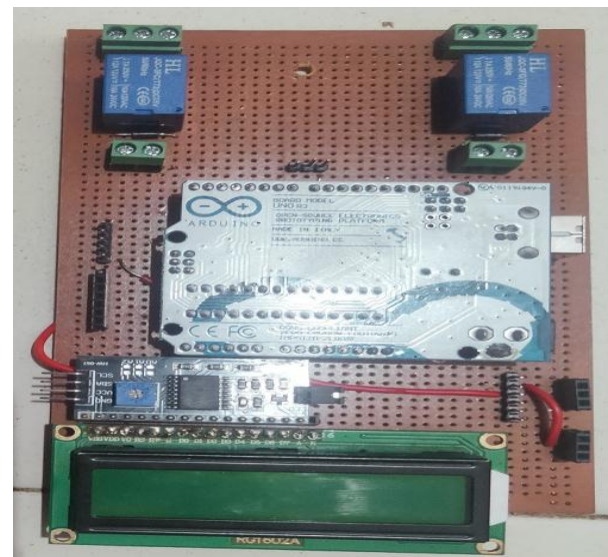

Fig -2: Control Unit

## 3. CONCLUSION

We describe a concept for circuit and fault current limitation in feeder system. The development is aimed at providing motivation and creating interest in the complex design of protection system, fault analysis, control circuit

design. An Overcurrent protection system was designed using microcontroller (Arduino). Thus, the proposed prototype protection system has been devised and implemented to trip the load elements successfully at different overvoltage and overcurrent conditions within a margin of error that might further be ameliorated upon future iterations of this scheme. This scheme is simple, moderately sensitive and reliable and may further be improved based upon this prototype to implement overvoltage and overcurrent protection simultaneously and improve the simplicity and efficiency of it. The aim of designing and constructing a low-cost Arduino based overcurrent protective device was achieved in this work. The device is found to be economical, easier to maintain and repair.

## REFERENCES

- 1) IEEE Transactions on Power Apparatus and Systems, Vol. PAS-104, No. 4, April 1985, Feeder Protection and Monitoring System, PART I: DESIGN, Implementation and Testing, by John Zeigler, B. Don Russell, Mike Aucoin.
- 2) International Journal of Research in Engineering, Science and Management, Feeder Protection from Over Load and Earth Fault Relay by Neha R. Ovhal, Maya G. Namwad, Vikrant Kumar, Akshay R. Khapekar, Neha V. Raut
- 3) Feeder Protection Challenges with High Penetration of Inverter Based Distributed Generation, Harag Margossian, Florin Capitanescu, Juergen Sachau Interdisciplinary Centre for Security, Reliability and Trust, University of Luxembourg