

# Design, Analysis and Optimization of Motorized Agriculture Weeding Tool

Deep Kishorkumar Bhatt<sup>1</sup>

<sup>1</sup>Graduate Student, Sardar Patel College of Engineering (Gujarat Technological University), Bakrol, Gujarat, India

\*\*\*

**Abstract** - The weeding tool in agriculture field is used to remove the weeds (Undesired plants) found near the desired crop. This weeding tool requires to work precisely during the weed removal operation depending upon the varied conditions of the farm-field to ensure no crop spoilage. While, the weeding tools which are available in the market, amongst many of them poses inability to work in certain condition because of their limited operational flexibilities. However, the design of weeding tool proposed in this paper is able to overcome incapability of conventional weeding tool attachments by governing motor powered, compact, light-weight and easy to maneuver design. Also, the proposed weeding tool can be utilized to perform various type of weeding operation such as intra-row, inter-row and in-between row weeding while ensuring precise removal of the weeds near the crops. In addition to the computer aided modelling of the tool, in this paper, the stress analysis of the computer aided design (CAD) of the proposed weeding tool using finite elemental analysis (FEA) method is also carried out for further design optimizations, and design of the tool is accordingly modified at the later stage after evaluating results of the analysis. Additionally, the designed tool was manufactured and tested on the field for empirical observation to perceive actual performance related information and substantiate optimization of the tool at the advance stage. Computer aided design, stress analysis and optimization of the weeding tool is performed holistically by using "Solidworks-2019" software in the proposed research.

**Key Words:** Motorised agriculture weeder, Computer aided design, Stress analysis, Field test, Empirical observation, Design Optimization

## 1.INTRODUCTION

Agriculture sector has been remained as economic backbone for many developing countries since pre-industrialisation era. The advancement especially in the agriculture field immensely enforces the economic upliftment of the developing nation. However, the agriculture sector is in itself enormous which brings up the wide gamut of operations and activities related to it. Farming is one of the associated activities that comes under the agriculture sector. Some of the important farming operations are ploughing, sowing, irrigation, weeding and harvesting. The proposed subject of the research is concerned with the weeding operation. Weeds are the undesired plants in the particular situation found on a field. A weed has a tendency of preventing the desired crop from getting nurtured by means of utilizing vitals given to the

desired crop, thus, making it extremely important to perform weed removal operation at various stages of growth of crop. There are numerous kinds of agricultural tools are available in the market that can serve distinguished operations as per the demand on the field. Among these tools, most tools are available as attachment which are driven by the power take-off (PTO) shaft of the tractors or tractor like agricultural machines. However, these tools which are attached to the tractor or alike equipment are not able to be used to remove weeds in between the crops due to the large design. Such situation led us to develop mobile and compact weeding tool which can be utilized in any soil condition, at any stage of crop and to perform any type of weeding such as Inter-row, Intra-row and In-between row weeding. The research study proposed in this paper deals with the three-dimensional modelling, stress analysis using finite elemental analysis technique, field testing and design optimization of the weeding tool. There are various components of the weeding tool which are mounting rotor, blade, motor shaft connector, fasteners and planetary geared motor. Three-dimensional solid model of the weeding tool assembly is as shown in the below figure 1.

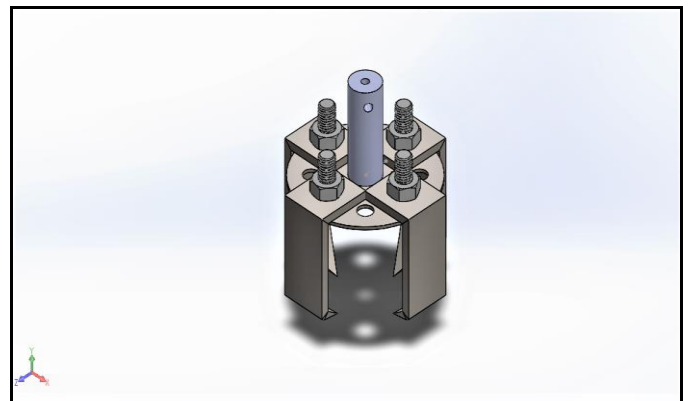

Fig -1: Weeding tool assembly (Without motor)

### 1.1 Details of component

The agriculture weeding tool presented in this paper has four different components. Which are as described below.

**I. Mounting rotor:** The mounting rotor is the circular base on which blades are mounted through fastening by using nut and bolt. The motor shaft connector is also fixed with the mounting rotor by means of welded joint. Since, the mounting rotor is welded with the motor shaft connector they mutually

act as a single moving body upon which blades are connected and consequently the blades also rotate as the rotor rotate.

**II. Blade:** Blade is one of the most important components of the whole assembly as it is the only part of the weeding tool assembly which ultimately performs the weed removal operation. There have been total four blades provided in the design. These blades are connected to the mounting rotor by mechanical fastening such as nut and bolt. When the motor is cracked up and starts rotating the blades connected to the mounting rotor also starts rotating. This rotation of the blades provides the rotational momentum while utilizing high torque of the motor, this in turn gives up the large amount of rotational force for removing the weeds coming into the direct contact with the blade. In the design of the blade, it is required to keep edges of the blade sharp enough to remove the weeds as efficient as possible.

**III. Motor shaft connector:** It is a hollow cylinder, with a hole on its surface to accommodate connector pin for fastening the motor shaft. Motor shaft connector basically bridges the motor with the tool assembly so that the rotation of the motor shaft can be transmitted to the tool. In the proposed design of the tool, the motor shaft connector is fixed to the mounting rotor using welded joint.

**IV. Motor:** Motor is the crucial element of the assembly, which is connected with the mounting rotor by the use of motor shaft connector. The shaft of the motor is inserted into the hollow motor shaft connector which is connected to it using connector pin. In particular, the weeding operation requires high amount of torque to force the weeds and further remove it from the roots. Therefore, the admissibility of the high torque motor in the system is important to ensure smooth operation. Given that fact, planetary geared electrical motor is used in the assembly, which not only provides the sufficient amount of torque but also is compact in design. The detailed specification of motor is outlined in the later section of the paper.

## 1.2 Proposed research objectives

The main objectives of the research are as follows:

- Design a compact and economic motor-powered weeding tool which can be utilized to remove weeds within the row and between the row as well.
- To do static stress analysis of the blade in the solidworks-2019 using finite elemental analysis technique.
- To analyze stress results and accordingly optimize the design by incorporating various modifications.
- To perform the field test of the tool assembly before applying any modification.
- Re-engineer the tool design by analyzing theoretical results and the on-field performance specific empirical observations.

- Re-evaluate the modified design using stress analysis to ensure design safety against failure and reliability.

## 2. LITERATURE REVIEW

The weeding operation is one of the important stages in the agriculture operation. There are several researches have been conducted and many are undergoing the research related to the design of various weeding tools and equipment. Many of them are related to the manual weeding tool and others are related to the equipment or attachment. However, design of mechanized weeding tool has always been at the center point of many modern researches, with the fact that, mechanization of the farm can benefit farmers and so the economy of the country in many ways.

One of the primary concerns in the field of agriculture is extremely diversified operations which require number of different tools to meet the demand. After studying the patent, we have found that **(Chakraborty Sneha)** has proposed a design of multipurpose agricultural tool which encompasses variety of tools in a single hand operated assembly. The main object of this invention is to reduce the inventory of agricultural tools. After referring and reviewing this literature, we get an enclosure of making our design flexible enough to support drastically distinguished tools.

The manual weeding tools which are available in the market have underlying inefficiencies regarding ergonomics of the design and tool performance. With this regard **(Dr. Rajiv Yadav & Sahastrarashmi Pund)** proposed a study on manually operated weeder while considering various parameters such as speed of travel, time of operation, field capacity, weeding efficiency and horse power requirement during the testing. The weeding efficiency of the developed weeder was satisfactory and it was easy to operate. It was found that the developed weeder could work up to 30 mm depth with field capacity of 0.048 ha/hr and higher weeding efficiency was obtained up to 92.5 %. During weeding operation, the peak heart rate of the subjects was found to range from 142 to 150 beats per min. In case of heavy work and dense grass infested field, the rest pause of 14 min was required by the subjects to come to the normal heart rate.

Removal of the weed is essential to ensure crop productivity on the field. There are several ways for removing the weeds. **(Snehal Shamkuwar, Swarnkar Swarnkar, Pankaj Gupta & Vinay Kumar Budhe)** have proposed study on different weed control techniques. Some methods of removal of weeds include use of chemical fertilizers. These methods are hazardous to the human consumption and also harmful to the environment. In order to ensure food security and sustainable agriculture development, it is critically important to ensure the agriculture produce to be free from chemical and environmental pollution.

### 3. METHODOLOGY

The basic procedure to design the tool includes six major stages which are data acquisition, calculation, motor selection, design and analysis, development and optimization.

The procedure employed is elaborated by the flowchart in the Fig. 1 shown below.

Each area of procedure shown in the flowchart is explained in detail in further sub-sections.

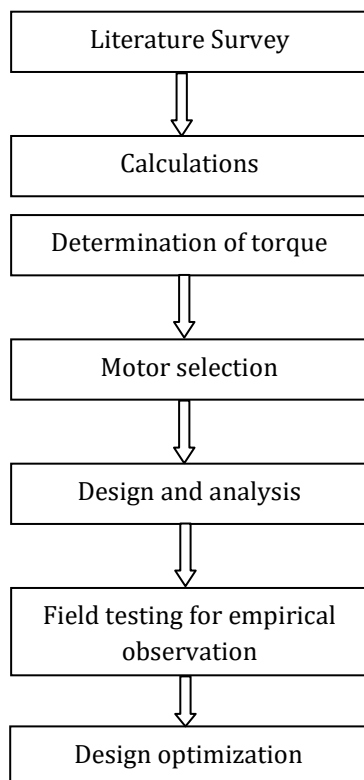

Fig -2: Research procedure

### 4. TORQUE CALCULATIONS

Calculation is by far the most important stage lies after the data acquisition. In this stage the required magnitude of torque needed to perform desired weeding operation is calculated. There are various assumptions and considerations taken into account during calculation, which are found to be appropriate on the various field condition during operation.

Determination of required motor torque

Considerations:

1. Depth of tool = 6.739 mm
2. Contact area of a blade = 68.79 mm<sup>2</sup>
3. Soil resistance = 0.5

Now, from the value of contact area of a single blade, the total area of contact for all blades is given by,

$$\begin{aligned} \text{Total contact area} &= 4 \times 68.79 \text{ mm}^2 \\ &= 275.16 \text{ mm}^2 \end{aligned}$$

Total force required is calculated by using the following equation.

Force required = total blade contact area x soil resistance

Now, putting the values in the above equation we get,

$$F = 275.16 \times 0.5 = 137.58 \text{ kg f}$$

$$F = 137.5 \times 9.98 = 1372.2 \text{ N}$$

Required torque can be determined by using following equation.

$$\text{Torque} = \text{Force} \times \text{Radius}$$

In our case the radius of rotor is considered while calculating the torque, which is, 20 cm or 0.2 m.

$$T = 1372.2 \times 0.2$$

$$= 274.44 \text{ N m}$$

Hence, the required torque is 274.44 N m.

### 5. MOTOR SELECTION

Once the required torque is calculated, the selection of the motor takes place. There are various kind of motors available to select, however, selection of the motor proceeded while considering different parameters of motor such as torque, speed, weight, power consumption, shaft pressure bearing capacity, electrical and thermal properties, rated electrical operational properties and cost. After conducting holistic research about different types of motor, the planetary geared dc motor was selected which satisfied all the prerequisites for the selection, with compact design, high torque, greater reliability and low power consumption.

Technical specifications of the selected motor are as given in the following table.

Table -1: Technical specification of motor

Motor type	Planetary geared motor
Operating voltage	12v DC
Motor speed at output shaft	300 rpm
Stall torque (Kg-cm)	40
Rated torque (Kg-cm)	10

**Table -2:** Other Base specification of motor

Normal voltage	12v DC
No load speed	18000 rpm
Rated torque (gm-cm)	151
No load current	0.8 A
Load current	Up to 7.5 A (Max.)

## 6. DESIGN AND ANALYSIS

### 6.1 Drawing of blade

The weeding tool proposed here encapsulates two main parts which are blade and mounting rotor. The design and analysis of blade have done in the software “solidworks-2019”. Although, the analysis of rotor is exempted as it is subjected to little or no direct contact with soil during the operation in normal conditions instead the blade is constantly under impact and wear during the operation of weeding.

The drawing of blade in different views are shown in below fig. 3 and fig. 4.

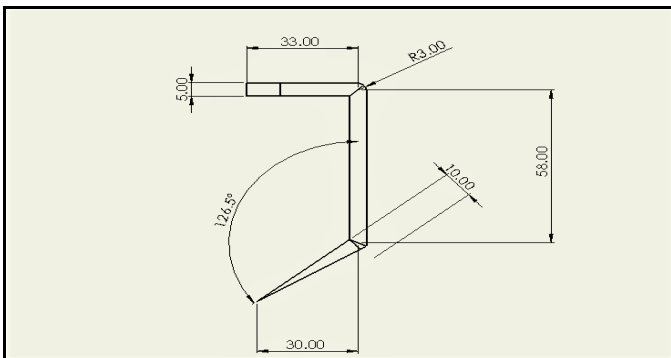

**Fig -3:** Front view of blade

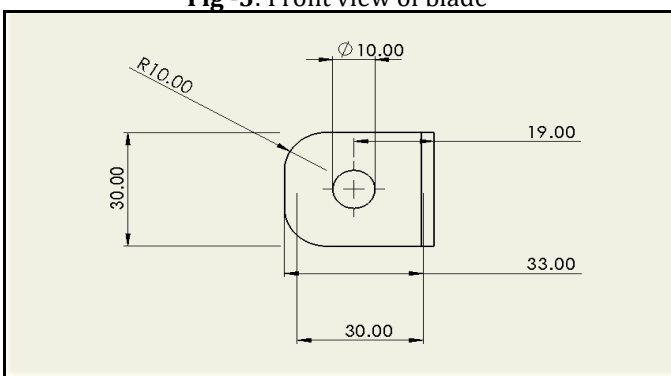

**Fig -4:** Top view of blade

In the design of the blade the sharpen edge is provided at the angle of 126.5 degrees to ensure smooth insertion of the blade in the soil during the weeding operation.

### 6.2 Material properties

In the research, for design of the tool, ASTM A36 STEEL was used as a material for the whole design of weeding tool, which is, in fact, the most commonly used and idle material to serve the purpose we need.

Some of the material properties of the same are mentioned in the below table 3 which are referred from the “solidworks-2019” material properties library.

**Table -3:** ASTM A36 STEEL material properties

Elastic modulus	200000 N/mm <sup>2</sup>
Poisson's ratio	0.26
Shear modulus	79300 N/mm <sup>2</sup>
Tensile strength	400 N/mm <sup>2</sup>
Mass density	7850 kg/m <sup>3</sup>
Yield Strength	2.5x10 <sup>8</sup> N/m <sup>2</sup>

### 6.3 Static stress analysis of blade

The result of static load stress analysis is governed by the von-mises maximum stress criterion. The type of mesh element which is used is blended curvature-based mesh, which is chosen in order to ensure as closer results as possible by incurring higher accuracy of meshing. Yield strength of the material is selected as the upper limit of the stress plot. The different plots of results of analysis are shown in fig. 5.

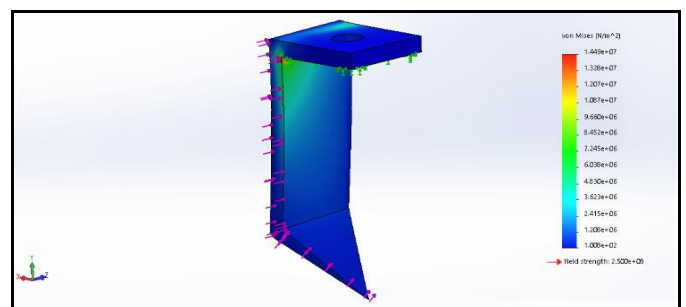

**Fig -5:** Result of Static stress analysis of a blade

From the above Fig. 4, it can be seen that the load is applied in the normal direction to the frontal surface of the blade because during rotation of the blade the frontal surface (surface of thickness) of the blade causes the removal of the weed. The magnitude of the load acting on the entire width surface is taken equal to the value of the stall torque of the motor from the motor specification table which is 78.456 N. Since beyond the stall torque motor will not be operable and so the tool. In addition, the value of maximum stress or von-mises stress induced in the blade is  $1.449 \times 10^7 \text{ N/m}^2$  which is under the yield strength of the material which ensures the design safety.

## 7. DEVELOPMENT OF TOOL

The tool was developed by using various advanced manufacturing equipment to meet the closer tolerances of the design. The mounting rotor and the holes were cut using computerised numerical controlled gas cutting machine. Furthermore, the blades were also cut using the same cutting machine. The bends on the tool were produced by using conventional bending machine and the motor shaft connector was turned using lathe machine. After manufacture of the tool, it was assembled and tested on the field for empirical observation of the performance.

### 7.1 Drawing of tool

Tool is represented in different views by following two-dimensional drawings of front view and top view are shown in fig.6 and fig.7 respectively. All the dimensions provided within the drawing are in mm.

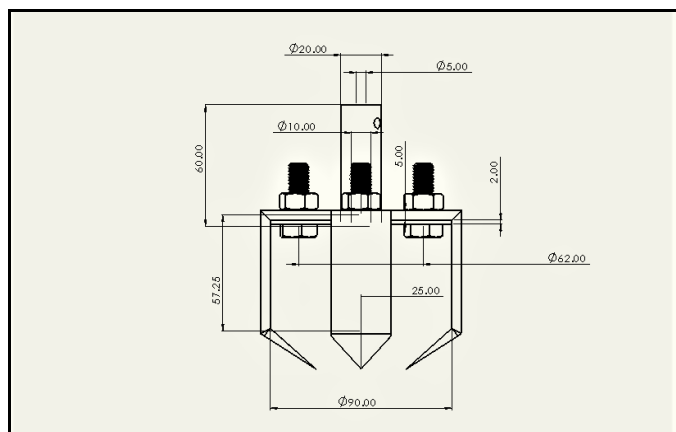

Fig -6: Front view of manufactured weeding tool

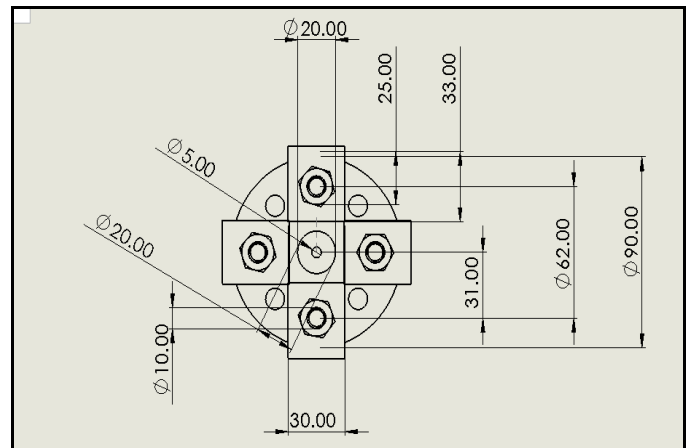

Fig -7: Top view of manufactured weeding tool

### 7.2 Field testing for empirical observations

After manufacturing of the weeding tool, the field testing was carried out on a random field with dry and wet soil. The underlying purpose to perform on field testing was to sought performance review by empirical observation, to further enhance the performance of weeding through certain design modifications if needed. After couple of operational tests of the tool on a field, few instances were experienced to be improvised subject to design modifications. Such observations are outlined below.

Outcomes of the empirical observation:

- During the operation of the tool, the power consumption by the motor was seen higher, measured by the multimeter, especially during the high depth weed removal
- Long weeds were seen to be trapped around the angle given at the end of the tool blade
- At some instances, the weeds were not removed from the roots
- It was also seen to have ineffective utilization of the working area due to the angle given at the end of the blade



Fig -8: Manufactured weeding tool during field testing

### 8. OPTIMIZATION OF TOOL

After analysing the outcomes of the empirical observation which can be improvised further, motivated to look forward towards the optimization of the tool. The design was optimized at greater extent against making few minute changes in the design of the blade of tool which can be seen in the fig.9. In addition, after modification of the design of the blade, it was again subjected to the static stress analysis for validating the expected output of the modified design.

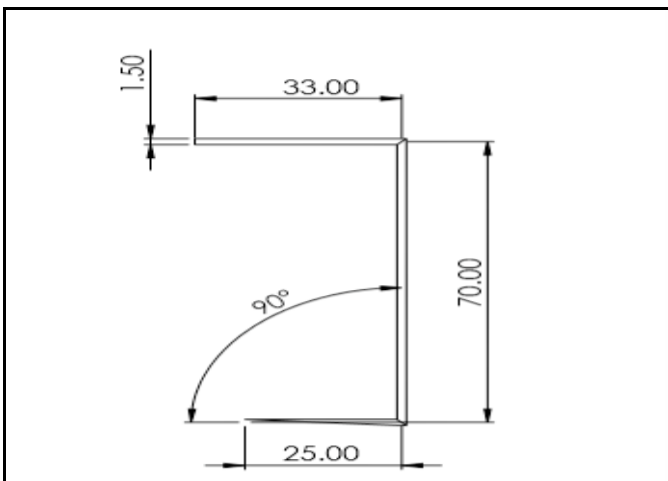

Fig -9: Front view of optimized blade of the tool

#### 8.1 Stress analysis of optimized tool blade

The optimized design of the blade was also subjected to similar boundary conditions and fixtures. Also, the magnitude and direction of the force acting on the blade were kept similar as they were in the analysis of the previous design of the tool blade. The result of static stress analysis of the optimized blade of the tool is as shown in the fig. 10.

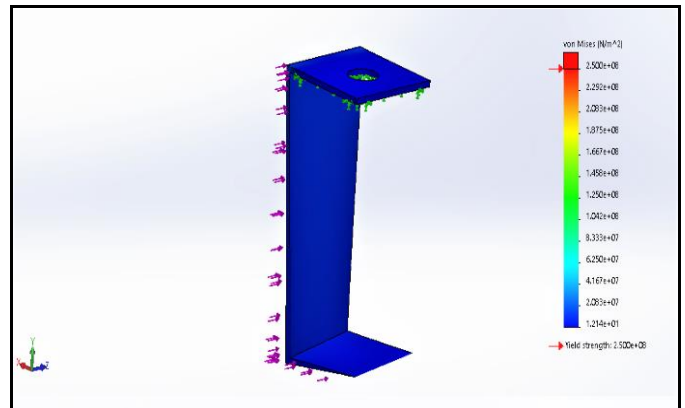

Fig -10: Result of the stress analysis of optimized blade of weeding tool

From the Fig. 10, it is evident that the von-mises stresses induced in the blade are lower than the yield strength of the material, which is valued as  $2.083 \times 10^7$  N/m<sup>2</sup>, with the calculated FOS of 1.20. This value of FOS is considered to be safe for the design as the proposed weeding tool is not subjected to the severe loading condition or else only the part of the blade is subjected to the friction and moderate shocks during the operation but not to the severe externals.

#### 8.2 Comparison of different parameters between old and optimized design of the blade

There are few changes made in the design of the blade such as the thickness of the blade is now reduced to 1.5 mm from 3 mm before which can be seen in the fig. 9. Another change is made by increasing the bend at the end of the blade to make it the right angle. The reduction in thickness has further reduced the weight of the blade which in turn will reduce the overall power consumption during the operation. The right-angle bend at the bottom of the blade increases the effectiveness of removing the weeds. Also, the area covered by the blade during operation is increased marginally which will help in increasing performance of the weeding tool. Moreover, apart from the right angle provided at the bottom part of the blade, the chamfer is also given to the blade at the end of the bottom part. This way the blade will ensure required sharpness and thus, reduce the torque requirement for the removal of the weed. The comparison between the old blade and the newly designed optimized blade is given in the below table 4.

**Table -4:** Comparison between old blade and optimized blade design

Parameters	Old blade design	Optimized design
Weight	110 gm	26.64 gm
Thickness	5 mm	1 mm
Strees	$1.449 \times 10^7$ N/M <sup>2</sup>	$2.083 \times 10^7$ N/M <sup>2</sup>

## 9. CONCLUSION

The tool was optimized in such a way while keeping in mind that it can help remove weed efficiently and without damaging the crop. Empirical observations carried out during the field test provided the details regarding the performance of the tool and areas in which the design can be improvised. By analysing the empirical observations, the modification of the blade seen crucial as minute modification in the design of the blade can have a large impact on the performance of the tool. The optimized design of the blade shown to fulfil all the aspects which were absent in the previous design with reduction in consumption of the power by the motor, more efficient removal of the weed and consistency in the performance reliability of the tool. Overall, the proposed research of the design of the weeding tool satisfied all the research objectives required to set forth and provided with the optimized design of the tool.

## 10. REFERENCES

- [1] Mr. Tejas B. Raut, Mr. Shubham P. Wagh, Mr. Ganesh V. Gawde et.al "Power Weeder", Volume 4 issue 03 ISSN: 2455-2631
- [2] Manish Chavan, Sachin Chile, Ashutosh Raut et.al "Design, development and analysis of weed removal machine", Volume 3 issue may 2015 pp-(526-532)
- [3] Rajat Bhosale, Akshay Herkar, Avinash Herkar, Narayan Shinde et.al "Design and Fabrication of Agricultural Rotary Weeder", Volume 3 issue 02. 2017 ISSN: 2394-409
- [4] Summet. A. Deshmukh, Akash. P. mandulkar, Anurag G. Choudhari et.al "Fabrication of engine operated weeder", Volume 5 issue April 2017 pp-(186-189)
- [5] Crafts, Alden S. (1975). *Modern Weed Control*. Berkeley, California: University of California Press. pp. 110-117. ISBN 0-520-02733-7.
- [6] Bin Ahmad, Mohd Taufik, "Development of an Automated Mechanical Intra-Row Weeder for Vegetable Crops" (2012). Graduate Theses and Dissertations. 12278.
- [7] Vijay Kamate, Dr. S. Mohan Kumar, "Ergonomic Assessment of Traditional Weeding Tools Usage and their Management in Indian Agricultural Practices", International Journal of Engineering Research & Technology (IJERT) ISSN: 2278-0181, Vol. 4 Issue 09, September-2015
- [8] Tewari, V. K., Datta, R. K., & Murthy, A. S. R. (1993). Field performance of weeding blades of a manually operated push-pull weeder, *Journal of Agricultural Engineering Research*, 55(2), 129-141.
- [9] Terpstra, R., & Kouwenhoven, J. K. (1981). Inter-row and intra-row weed control with a hoe-ridger, *Journal of Agricultural Engineering Research*, 26(2), 127-134.
- [10] Home, M., (2003). An investigation into the design of cultivation systems for inter and intra-row weed control (Doctoral dissertation, Cranfield University, Silsoe). <http://krishikosh.egranth.ac.in/displaybitstream?handl e=1/5810000572>
- [11] Merfield, C., & Jabran, K. (2018). Mechanical weed control. In *Non-Chemical Weed Control*. Academic Press. 1st Edition, Elsevier, Academic Press, London, United Kingdom. pp. 133-155. Retrieved from <https://www.researchgate.net/search>