

VEHICLE SAFETY CONTROLLER FOR DUMPTRUCKS

SHWETHA Y N¹, SINDHU S P¹, VANDANA V B¹, Dr.MANJULA A V²

¹UG Student, Dept. of Electronics and Communication Engineering, NIE Institute of Technology, Mysore, Karnataka, India.

²Associate Professor, Dept. of Electronics and Communication Engineering, NIE Institute of Technology, Mysore, Karnataka, India.

Abstract - Heavy duty starting motor, Alternator and parking brake systems are used in Dump trucks for engine start, battery charging and vehicle braking respectively. These items are high value items and critical for equipment operation. The frequent/premature failure of starting motor, alternators and parking brake systems are being reported from customer site and equipment's are being kept under break down which in turn affect on equipment availability and also leads to huge penalty. Presently, the limited safety systems are available on the equipment for protection of these high value items, the new controller may be developed for protection of these systems and also to improve the safety and reliability of the equipment.

Key Words: STARTER MOTOR, PARKING BRAKE SOLENOID, BATTERY RELAY, FUEL CUT_OFF SOLENOID, FAULT_DETECTION AND DISPLAY.

1. INTRODUCTION

Electrical System is one in all the vital elements of automobiles, totally different systems or parts sort of a storage battery, generator, starter motor, ignition, parking-brake and numerous accessories, As Dump trucks were used for material transportation majorly, they were labeled as workhorses within the housing industry. Though they're helpful in most things they need been inflicting serious injuries and fatalities .

When we activate the key to the start position, if the transmission is within the park or neutral, the battery voltage goes through the starter feedback loop and activates the starter system, the starter coil flipping over the engine rotating shaft permitting the engine to start out if it's properly do its job the motor won't be ready to spin because of series of clicking that happens as we have a tendency to turn the key to on position.

The alternator could be a generator of electrical power in vehicles, once the engine starts running, the alternator charges the battery and provides further power for the vehicle electrical system. It fails because of the undercover of the

engine, a coolant or oil conjointly damages the generator

The parking brake is to confirm that a position vehicle keep in an exceedingly place particularly on hills or declines or locks the wheels in situ and to prevent the vehicle if the most brake fails. Controller unit is employed within the place wherever we'd like a lot of safety for high-value things

Engine speed signal comes from magnetic pickup device mounted on the engine, relaying upon the model, the number of teeth can vary magnetic pickup device facing those teeth, every teeth offers one pulse, and relying upon the time we are able to notice the engine speed. Oxygen, and spark measure needed to burn the fuel.

2. RELATED WORK

Gone through the working of starter system with safety relay at BEML Ltd

The twenty-four volts provide from the 'C' terminal of the key switch connected to the 'NO' terminal of safety relay and therefore the 'COMMON' terminal connected to the magnetic relay through the neutral switch. Coil terminal of safety relay connected to 'coil' terminal of the alternator. And another end of the coil terminal is connected to twenty-four volts provide. When Key switch is within the 'ON' position, the safety relay coil gets twenty-four volts and another terminal connected to the generator gets ground within the alternator.

When the engine starts, the alternator produces twenty-four volts provide to the safety relay and each terminal of safety. Then, the starter circuit contacts are going to be open. If the operator by mistake starts the engine, the starter wouldn't get provide, and therefore the starter wouldn't start out the engine, a DC motor is employed. DC motor fitted with a coil. Electric battery cabled from twenty-four volts battery is connected to a coil positive terminal. Twenty-four volts management wire from 'C' terminal of the key switch connected to

coil terminal of the magnetic relay. This wire is connected in nonparallel with a safety relay and neutral switch.

The starter could be a DC motor once Key switch is changed into a crank 'C' position, a twenty-four volts provide energizes the coil of the magnetic relay. The magnetic relay energizes and the contractor closes and twenty-four volts provide connections to the coil terminal.

The coil energized and 2 terminals came into contact and battery voltage connects the availability to starter winding. Once the starter coil gets twenty-four volts provide, the coil energizes and a plunger moves the pinion of the starter. The pinion rotates and therefore the engine can begin. Once the key comes into the 'ON' position from the 'C' position starter can stop the rotation

The reliability of the starter is going to be less. So, a safety relay saves a starter price and avoids damaging to the flywheel by finance minimum price we are able to save higher price and time, waste of workforce and breakdown time of apparatus

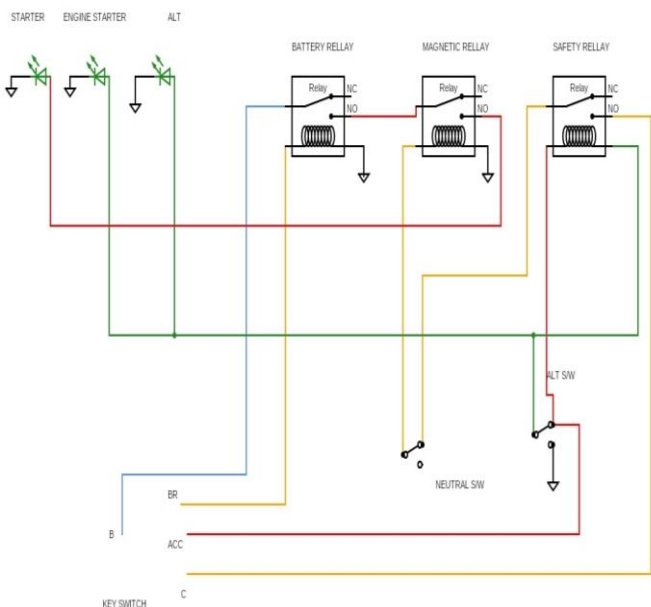

Fig-1.1: starter system with safety relay

2.1 DRAWBACK IN THE EXISTING SYSTEM

Once Key switch or the ignition switch is turned to start out position, cranks the engine that consists of an easy circuit however there's an opportunity of obtaining broken attributable to variety of loading to the starting motor that ends up in failure of the starter motor.

If the vehicle isn't in an exceedingly neutral position and if it's cranked then the vehicle could move and ends up in accidents. Battery and alternator lead warming or overheating. If the battery voltage is on top of a particular voltage consistent with the provided specification.

once a vehicle is stopped parking brake has to be activated however if it gets activated in running position ends up in a lot of major loss like entire parking brake system gets an injury and lots of different issues could cause it.

In running condition flywheel RPM will be high. In this condition if starter cranks, the pinion of starter will get damaged and even starter also get damaged. At high RPM engine should not turn off suddenly, if it is turned off bearing of the vehicle is damaged because when it is running at higher RPM, there will not be proper lubrication and will be high temperature which leads to damage.

3. METHODOLOGY

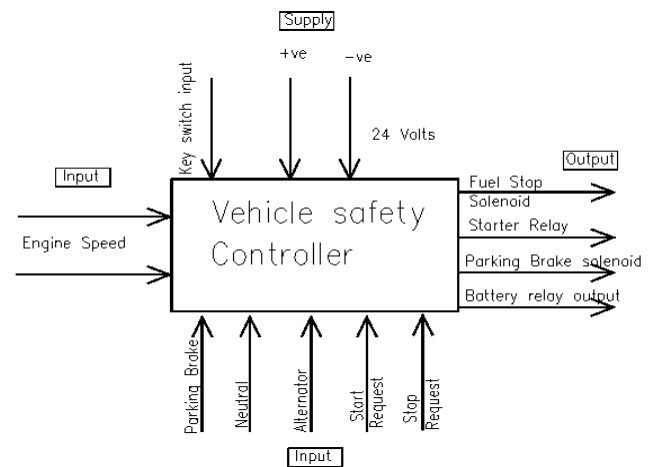

Fig-2.1: Block diagram

The following measures are incorporated within the controller for the defense of high price things

1. Starter Motor: starter motor on/off through controller. Once the vehicle is in neutral and battery voltage is high, beginning output is going to be provided. variety of cranks and cranking amount is controller, If engine speed is a gift, the cranking isn't allowed
2. Alternator: If the alternator signal isn't gifted and therefore the battery voltage is low, shut down the vehicle battery relay.
3. Engine stop: Engine stops is going to be commanded only the engine rate(rpm) is

lower and delay of one minute once receipt of engine stop request. this can be done to avoid failure of turbocharger because of hot closedown

4. Parking brake actuation: Parking brake will be actuated only when equipment is in neutral engine speed is high and equipment is out of neutral.

3.1 FLOW CHART

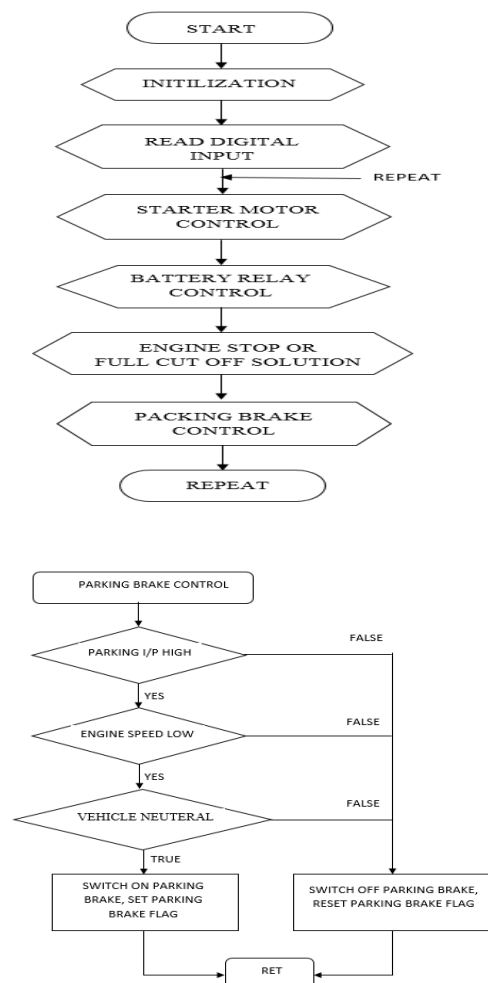

Fig 3.1.1 Parking brake solenoid control

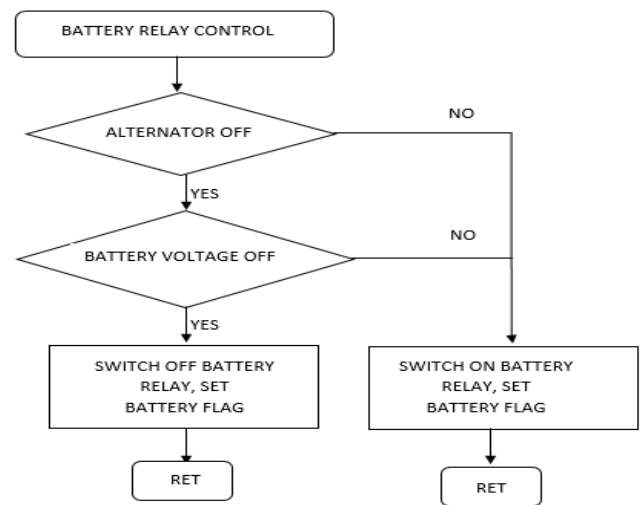

Fig 3.1.2 Battery relay control

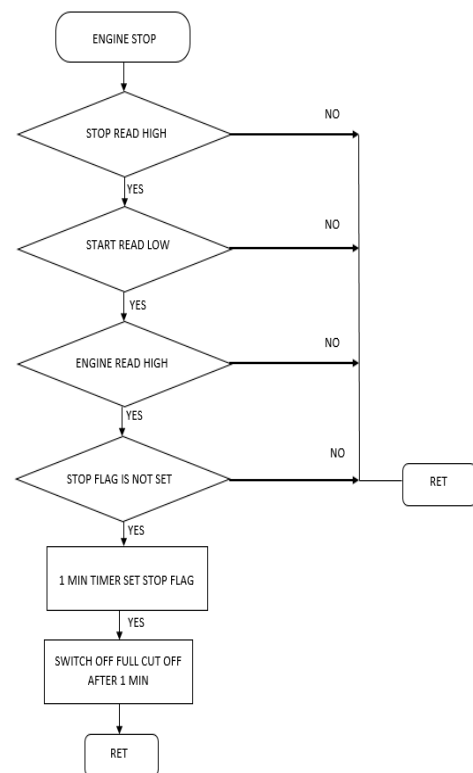

Fig 3.1.3 Fuel cutoff solenoid control

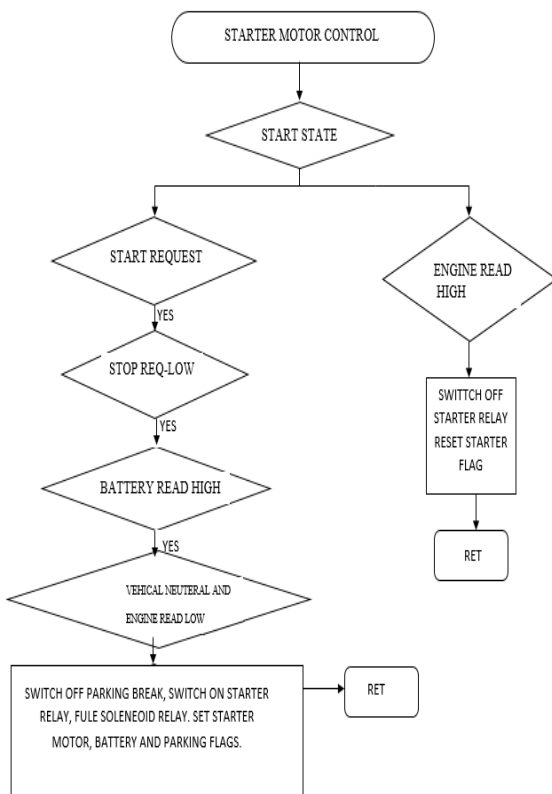

Fig 3.1.4 Starter motor control

3.2 DESIGN AND IMPLEMENTATION

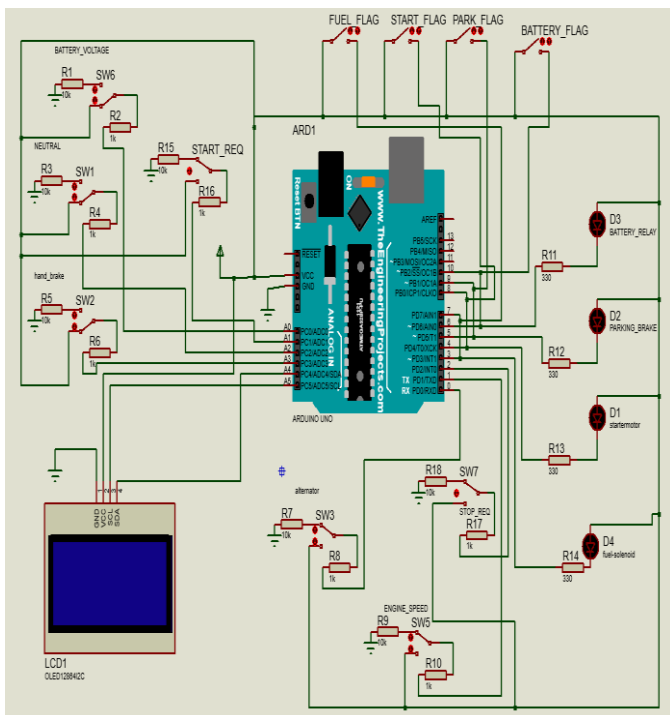

Fig – 3.2: shows the prototype of hardware circuit

we have seven inputs start request, neutral input, hand brake, battery voltage, alternator input, engine speed signal, and stop request signal, passing these input signals to Arduino input pins from A0 to A3 and zero to two, the input signals is 24-volt signal, therefore, resistor circuit to convert to five v signal by victimization $V_{out} = v \text{ in } (R2/R2+R1)$. Output measure provided through three to five pins and to avoid the injury to diode, resistors are used and error management signals like battery relay control flag ,parking brake solenoid control flag ,starter motor control flag and fuel cut-off solenoid control flags are passed to seven to tenth digital pins of Arduino, OLED is employed to show the fault detection.

Table-1: Operating conditions

CONDITIONS	INPUTS							OUTPUTS			
	Battery voltage	Start request	Neutral	Hand brake	Alternator	Engine speed	Stop request	Battery relay	Parking brake	Stator Relay	Fuel cut off solenoid
During power on time	High	Low	High	High	Low	Low	Low	On	On	Off	Off
After start request	High	High	High	Low	Low	Low	Low	On	Off	On	On
If engine speed rises	Low	High	High	Low	Low	High	Low	Off	Off	Off	On
If start request become low and stop request rises	Low	Low	High	Low	Low	Low	High	Off	Off	Off	Off

3.3 RESULTS AND DISCUSSION

During power on condition battery voltage is high and vehicle is in neutral and hand brake is applied this time battery relay and parking brake is get turned on. When giving start request starter relay and fuel-cut off solenoid get turned on .when engine starts, parking brake will not be actuated and battery relay gets turns off. When engine speed rises the starter motor relay gets turned off .Using error control flag that is connected to error control inputs, if any errors depending on flags the fault detection is displayed on OLED. For evaluation of algorithm, environment used are Arduino c ide and Proteus 8.9. Arduino IDE board is provided with Atmega 328P. All the conditions are worked according to the Table-1.

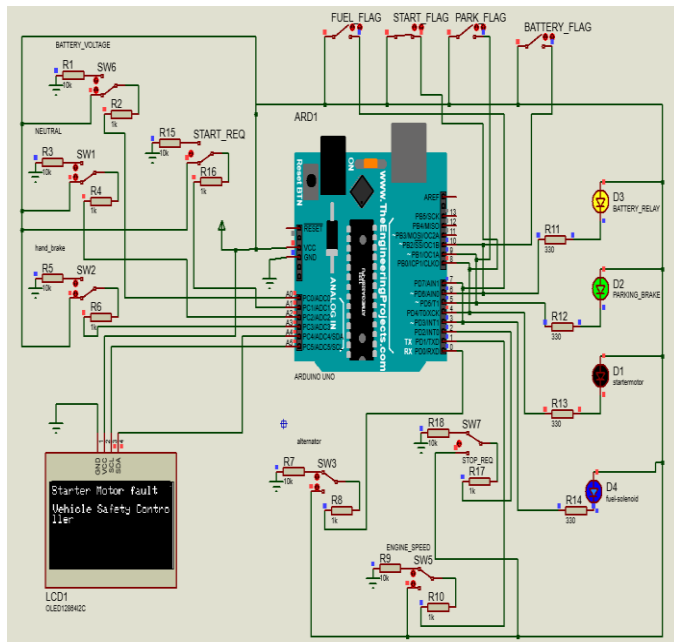

Fig-3.3: simulation result

3.4 CONCLUSION

In advanced operations malfunctions could cause the failure of major things, to shield them we have a tendency to developed a vehicle safety controller that detects the starting motor, alternator, battery relay, and fuel cutoff solenoid faults and showing the faults on the display unit. The high-value things price is high victimization this system we are able to avoid the cost, it's a money-saving and industrial project it is often employed in the car field to shield the high-value things. For future reference, continuous watching of battery voltage and engine speed is taken into thought, we'll use audio signals to tell the driving force concerning faults that will be a lot of economical.

ACKNOWLEDGEMENT

- [1] R.Brahmachari, Training head, BEML Ltd, Mysore
- [2] Jaykumar, Rand D head, BEML Ltd, Mysore
- [3] Acyuth kumar, DGM R and D, Data care systems Pvt Ltd, Bangalore
- [4] Naveen R and D engineer, Data care systems Pvt limited, Bangalore

REFERENCES

- [1] IGBT based Induction Motor Soft Starter by Sneha M Mukare, 'IOSR Journal of Electronics and Communication Engineering' (IOSR-JECE) ISSN: 2278-2834, ISBN: 2278-8735, PP: 27-32.
- [2] An Overview of Microcontroller Unit: From Proper Selection to Specific Application by Manas Kumar Parai, Banasree Das, Gautam Das, 'International Journal of Soft Computing and Engineering', (IJSCE)ISSN: 2231-2307, Volume-2, Issue-6, January 2013.
- [3] Battery Monitoring System using Microcontroller by S. N. Patil, Sangmeshwar S. Kendre, Dr. R. C. Prasad 'International Journal of Computer Applications', (0975 - 8887) Volume 28- No.6, August 2011).
- [4] Faults and Fault Diagnosis Methods by Chandramohan.G, Senthil Kumar.M., Rudramoorthy.R, Ashok Kumar.L, Suresh Kumar.R. 'ARNP Journal of Engineering and Applied Sciences', VOL. 7, NO. 7, JULY 2012 ISSN 1819-6608.
- [5] <https://blog.nationwide.com/what-is-an-alternator/>
- [6] <https://www.samarins.com/glossary/starter.html>
- [7] https://en.m.wikipedia.org/wiki/Starter_solenoid
- [8] <http://constructionmanuals.tpub.com/14273/css/Neutral-Safety-Switch-59.htm>