

A NOVEL SMART SYSTEM FOR WOMEN SECURITY

G.V. Sai Bharadwaj^{*1}, A.Venkata Varalakshmi^{#2}, B. Sai Manasa^{#3}, K. Madhuri^{#4}, V. Tejesh^{#5}

**Assistant Professor, ECE Department, Visvodaya Engineering College, Kavali, Nellore (Dt.), Andhra Pradesh.*

#UG Student, ECE Department, Visvodaya Engineering College, Kavali, Nellore (Dt.), Andhra Pradesh.

Abstract - Women are less protected in today's society and encounter several security issues. They must face a range of difficult situations and demonstrate their abilities on all important occasions. As a result, the government has given protection to the society through rules and regulations for their security and safety. An ATmega328 controller, as well as sensors such as an accelerometer sensor, a pulse rate sensor, a sound sensor, and a switch, are used in this project to create a safe and secure electronic system for women. When a woman is in danger, the gadget detects bodily characteristics such as heartbeat rate via the Pulse Rate Sensor, pressing a switch, feeling down position by the Accelerometer Sensor, and the victim's voice via the Sound Sensor. When the sensor exceeds the threshold limit, the gadget activates and tracks the victim's location using the GPS module and sends the SMS using the GSM module, the victim's location is transmitted to the registered contact number.

Key Words: GSM, GPS, Accelerometer sensor, SMS and ATmega328 controller

1. INTRODUCTION

Security refers to the state of being secure from injury or loss. Security is a term that refers to a sense of well-being. The distinction between the two is an extra emphasis on being protected from external threats. Individuals or acts that jeopardize the state of protection are to blame for the breach of security. In general, the word "security" is identical with "safety," but as a technical phrase, "security" indicates that something is not just secure, but has also been secured.

Women's presence remains invisible to both men and women, and this invisibility persists at all levels, from the family to the nation. In today's society, women are less safe and face several security challenges. The general truth is that no beneficial action would have any result in a house where all the deities are happy, where women are honoured, and where they are humiliated. Criminality against women is a heinous crime against mankind. One-third of all women will experience abuse and violence at some point in their lives. Such events have become increasingly prevalent in recent years, which prompted us to develop the suggested method.

This suggested method will be beneficial to all women throughout the world since it will not necessitate any additional effort for carrying the gadget.

They must go through a variety of challenging scenarios and must prove themselves in all key occasions. As a consequence, the government has provided security and safety to the society through laws and regulations. Regardless of the fact that there are several security systems available today, the need for advanced smart security systems is increasing. To address such issues, a smart security system for women is being built.

2. EXISTING SYSTEMS

Many developers have emerged in response to women's concerns, including: Codes such as *91# are used to offer emergency assistance, alerting police control. The free smartphone application 'Help me on mobile' was released to aid individuals in need of emergency assistance. This task is performed by these programs with a single click. However, when a female is in difficulty, she may be incapable of picking up the phone and pushing the button.

- A. SHE (Society Harnessing Equipment):** This is a clothing implanted with an electronic gadget that delivers a 3800kV electric shock to assailants, allowing the victim to flee.
- B. Smart Belt:** This solution is comprised of a portable gadget that resembles a standard belt. It is made out of an Arduino board, a shrieking alarm, and pressure sensors.
- C. Watch Over Me:** This is an app that converts your phone into a personal safety device. It tracks the user's travel and notifies the contacts if he or she does not arrive at the location on time. In the event of an assault, the user must shake the phone to activate the alert.
- D. Witness:** With Witness, users may instantly broadcast their position, voice, and video to loved ones. It will notify emergency contacts via phone and SMS, as well as broadcast live video, audio, and our position. iOS. The devices described above are only a few examples of safety and security equipment that have been deployed.

2.1 Drawbacks of Existing System:

Many electronic gadgets and systems are utilized to offer women with security.

- An active internet connection is required for this application.
- The user must enter proper data or else the system will operate strangely.

3. OBJECTIVES OF PROPOSED SYSTEM

This project covers existing safety devices for women's self-defence.

1. By implementing and employing our suggested method, not only will women's safety be ensured, but important items will also be available at a lower cost.
2. A switch will be used to turn on the gadget.
3. The sound sensor can be used to activate the system instead of the motion sensor.
4. When the ladies are in danger, the gadget detects bodily characteristics such as heartbeat rate using the Pulse Rate Sensor.
5. The Accelerometer sensor identified a down position. The device activates and monitors the victim's location using the GPS module while sending SMS using the GSM module, and the victim's location is communicated to the registered contact number when the sensor exceeds the threshold limit.

4. PROPOSED SYSTEMS

This project proposes a method for detecting women's safety utilizing GPS and GSM modems. The system may be linked to a switch and various sensors, which send alerts to family. A GPS receiver, a microcontroller, and a GSM modem are used in this detection and messaging system. The GPS receiver receives position data from satellites in the form of latitude and longitude. This information is processed by the microcontroller and transmitted to the user through GSM modem. The MCU is linked to a GSM modem.

The GSM modem delivers an SMS message to the specified mobile phone number. When a woman is in danger and requires self-defence, she can activate the switch assigned to her. By pressing the switch, the complete system is engaged, and an SMS with position information is immediately sent to the concerned person through GSM and GPS.

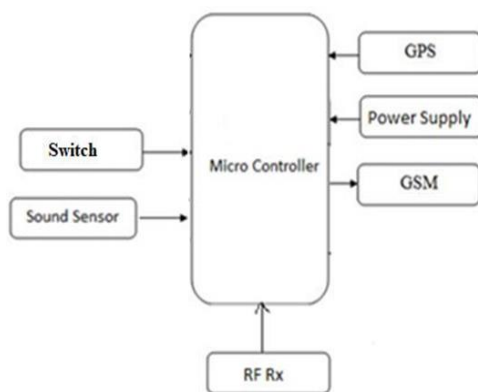

(a) Master Unit

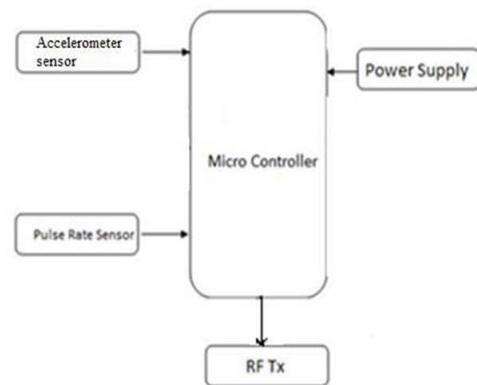

(b) Slave Unit

Figure 1: Block diagram of the Proposed System

4.1 Hardware Components:

Arduino UNO Board: The Arduino Uno is a microcontroller board that is powered by the ATmega328P. (datasheet). It features 14 advanced data/yield pins (six of which are often used as PWM yields), six basic data sources, a 16 MHz quartz, a USB connection, an impact jack, an ICSP header, and a reset button. Figure 2 depicts the Arduino Uno Board. In this project, the main controller is an Arduino Uno, which collects data from an IR sensor and a door closing detecting mechanism and processes it to do the necessary actions.



Figure 2: Arduino Uno Board

GSM: GSM (Global System for Mobile Communications) is an open, broadcast communications innovation utilised for mobile voice and data administrations communication. Figure 3 depicts the GSM Module. In this endeavour, the GSM MODEM is used for warnings by sending messages to the group and concern division with location.



Figure 3: GSM Module

GPS: Figure 4 shows a NEO-6M GPS chip from U-blox at the core of the module. The chip is about the size of a postage stamp, yet it packs a surprising number of functions into its small frame. It can monitor up to 22 satellites on 50 channels and reaches the highest degree of sensitivity in the industry, -161 dB tracking, while requiring just 45mA of supply current. The NEO-6M chip's operational voltage ranges from 2.7 to 3.6V.

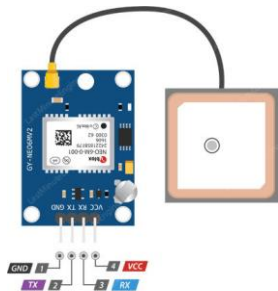

Figure 4: NEO-6M GPS Module

Accelerometer Sensor: Accelerometers are used to detect vibrations in vehicles, machinery, buildings, process control systems, and safety systems. They may also be used to detect seismic activity, tilt, machine vibration, dynamic distance, and speed with or without gravity.

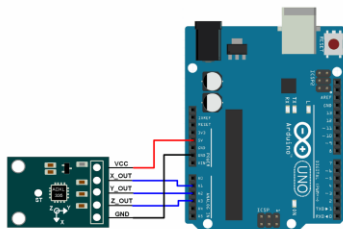

Figure 5: Accelerometer Sensor

Sound Sensor: These sound sensors are cheap, simple to use, and capable of detecting speech, claps, or door knocks. Figure 6 shows how we may utilize them for a number of sound reactive projects, such as making our lights clap-activated or keeping a "ear" on our pets while we're gone. The tiny diaphragm within the microphone is actually one plate of a capacitor. The rear plate, which is near to and parallel to the diaphragm, is the second plate.

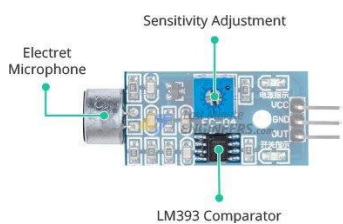

Figure 6: Sound Sensor

Pulse Rate Sensor: Figure 7 depicts the Pulse Sensor, a well-designed plug-and-play heart-rate sensor for Arduino. Students, artists, sportsmen, makers, and game and smartphone developers that wish to effortlessly incorporate real heart rate data into their creations can utilize it. The sensor attaches to a fingertip or earlobe and connects to Arduino via jumper wires. It also comes with an open-source monitoring software that tracks our heart rate in real time.

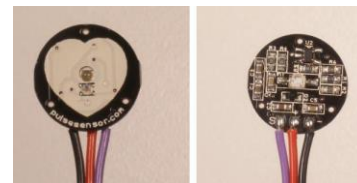

Figure 7: Pulse Rate Sensor

Switch: Figure 8 shows how switches link two open terminals in a circuit. When we press the pushbutton switch linked to pin 8, the LED on pin 2 illuminates. When external devices are removed or impedance levels are high, pull-down resistors are employed in electrical logic circuits to ensure that inputs to Arduino settle at desired logic levels.



Figure 8: 2-Pin ON/OFF Switch

433 MHz RF Tx and Rx Module: The 433 MHz RF transmitter and receiver module is a pair of tiny RF (radio-frequency) electrical modules that are used to broadcast and receive radio signals between two devices. Figure 9 depicts the transmitter module sending data from the transmitter end and the receiver module receiving data from the reception end.



Figure 9: 433 MHz RF Tx and Rx Module

LCD: A liquid-crystal display (LCD) is a flat-panel display or other electronically controlled optical device that employs liquid crystals' light-modulating capabilities in conjunction with polarizers. A 16x2 LCD has two such lines and can display 16 characters per line. On this LCD, each character is represented by a 5x7 pixel matrix. As shown in Figure 10, this LCD has two registers: Command and Data.



Figure 10: 16X 2 LCD Module

4.2 ARDUINO IDE software:

The designed board and serial port are presented in the bottom right-hand corner of the window. The toolbar buttons may be used to check and upload programs, as well as to generate, open, and save drawings and to launch the serial monitor.

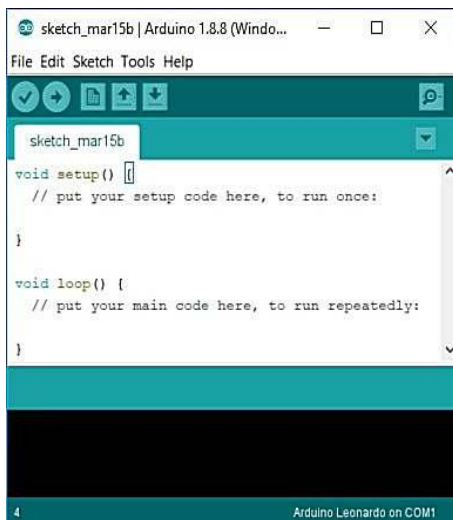

Figure 11: Arduino IDE

5. WORKING

The suggested system is a safe and secure electronic system for a woman that includes an ATmega328 controller, sensors such as MEMS, a pulse rate sensor, a sound sensor, and a switch. When the woman is in danger, the gadget detects bodily characteristics such as pulse rate via the Pulse Rate Sensor, pressing a switch, feeling down position by MEMS, and the victim's voice via the sound sensor. When the sensor exceeds the threshold limit, the gadget activates and tracks the victim's location using the GPS module while sending SMS using the GSM module, the victim's location is transmitted to the registered contact number.

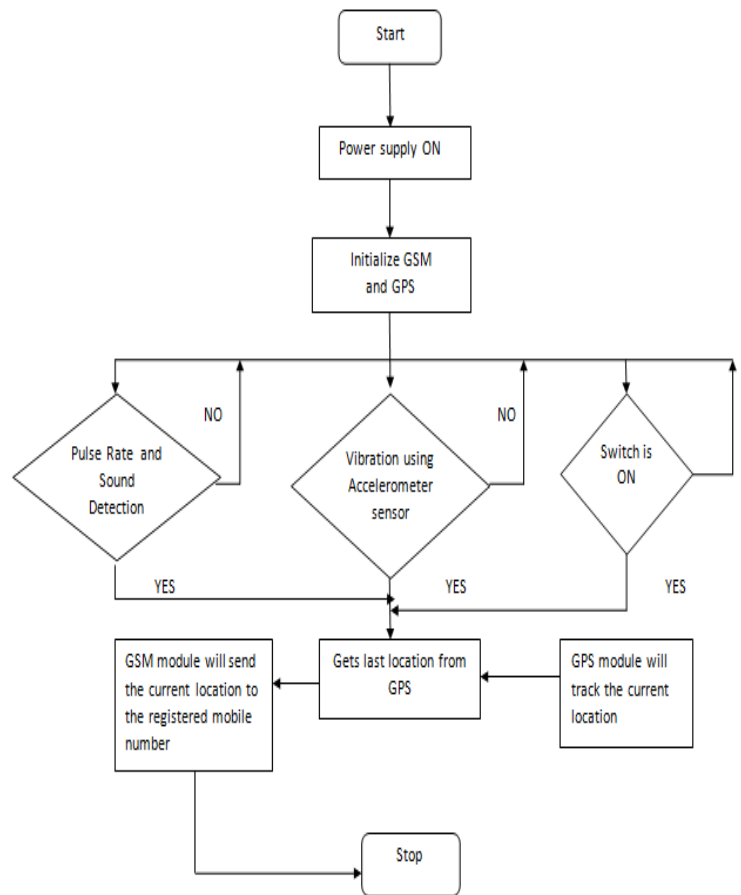

Figure 12: Flow chart of Proposed System

6. ADVANTAGES

- ✓ It is secure and simple to use.
- ✓ It is simple to trace a woman's location.
- ✓ It may be used by youngsters, adolescent girls, women, and elderly ladies;
- ✓ The mobile number can be changed at any moment.
- ✓ Reasonably priced yet not too so

7. RESULTS



Figure 13: Working Model of Proposed System



Figure 14: When Pulse Rate Detected by Pulse Rate Sensor then SMS sends to Registered number

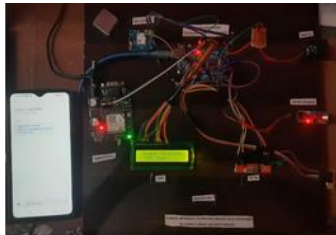

Figure 15: When Sound Detected by Sound Sensor then SMS send to registered number



Figure 16: When Switch is pressed then SMS send to registered number



Figure 17: When tilt Detected by Accelerometer Sensor then SMS send to registered number

8. CONCLUSION AND FUTURE WORK

The suggested design would address important challenges confronting women and will aid in their resolution via the use of cutting-edge technology and concepts. With the aid of real-world system implementation of the suggested model, the crime against women may now be put to a stop. The women's safety device is the most cost-effective answer to the difficulties that women confront in India.

It gives trusted contacts with real-time position information, which is then converted into a distress message, allowing major casualties to be avoided.

In the future, replacing the used Arduino Uno Board with an Arduino LilyPad that can be stitched onto textiles will assist to reduce the device's size. Because it consumes little power, rechargeable batteries may be utilized to make it more portable.

ACKNOWLEDGEMENT

We would like to thank all who have helped us in completing this project. We would like to thank our Guide and H.O.D of Electronics and Communication Department, Visvodaya Engineering College for providing us an opportunity to work on project "A NOVEL SMART SYSTEM FOR WOMEN SECURITY".

REFERENCES

- [1] Vamil B. Sangoi, "Smart security solutions," International Journal of Current Engineering and Technology, Vol.4, No.5, Oct-2014.
- [2] Simon L. Cotton and William G. Scanlon, "Millimeter - wave Soldier -to-soldier communications for covert battlefield operation," IEEE communication Magazine, October2009.
- [3] Alexandros Plantelopoulous and Nikolaos G. Bourbakis, "A Survey on Wearable sensor based system for health monitoring and prognosis," IEEE Transaction on system, Man and Cybernetics, Vol.40, No.1, January2010.
- [4] B. Chougula, "Smart girls security system," International Journal of Application or Innovation in Engineering & Management, Volume 3, Issue 4, April2014.
- [5] Hock Beng Lim, "A Soldier Health Monitoring System for Military Applications," International Conference on Body Sensor Networks.
- [6] PalvePrasad, "GPS Based Advanced Soldier Tracking with Emergency Messages & Communication System," International Journal of Advance Research in Computer Science and Management Studies Research Article, Volume 2, Issue 6, June2014.
- [7] AbhijitParadkar, Deepak Sharma, "All in one Intelligent Safety System for Women Security", International Journal of Computer Applications (0975-8887) Volume130-No.11, November2015.
- [8] Rajesh, M., and J. M. Gnanasekar. "Path Observation Based Physical Routing Protocol for Wireless Ad Hoc Networks." Wireless Personal Communications 97.1 (2017):1267-1289.

[9] Rajesh, M., and J. M. Gnanasekar. "Sector Routing Protocol (SRP) in Ad-hoc Networks." Control Network and Complex Systems 5.7 (2015):1-4.

BIOGRAPHIES



Mr. G. V. SAI BHARADWAJ completed his M.Tech in Digital Electronics and Communication Systems from Sree Rama Engineering College, Tirupathi, Chittoor (DT). He completed his B.Tech in Electronics and Communication Engineering from RSREC, Kadanuthala. He has published few papers in UGC Journals. Currently he is working as an Assistant Professor in ECE department at Visvodaya Engineering College, Kavali, and Nellore (DT). His areas of interest include embedded systems, Mobile Communications.



A. V. VARALAKSHMI, as B.Tech student in the department of ECE at Visvodaya Engineering College, Kavali. She has completed B.Tech from JNTUA University. Her areas of interests are Networks, Embedded Systems, Object Oriented Programming Language and Artificial Intelligence.



B. SAI MANASA, as B.Tech student in the department of ECE at Visvodaya Engineering College, Kavali. She has completed B.Tech from JNTUA University. Her areas of interests are Networks, Embedded Systems, Dot Net and Image Processing.



K. MADHURI, as B.Tech student in the department of ECE at Visvodaya Engineering College, Kavali. She has completed B.Tech from JNTUA University. Her areas of interests are Image Processing, Web Designing, Networks and Python.



V. TEJESH, as B.Tech student in the department of ECE at Visvodaya Engineering College, Kavali. He has completed B.Tech from JNTUA University. His areas of interests are Embedded Systems, Java, Networks and Web Designing.