

# Study and a Review on Carbon Nanotubes, Synthesis, and Analysis of CNT Reinforced Polymer Composites

Gaurav Katiyar<sup>1</sup>, Dr. Vinay Pratap Singh<sup>2</sup>

<sup>1</sup>Student, Mechanical Engineering Department, HBTU Kanpur

<sup>2</sup>Assistant Professor, Mechanical Engineering Department, HBTU Kanpur

\*\*\*

**Abstract** - With the recent advancements and developments in nanotechnology, the use of nanomaterials has increased manifolds in industrial sectors. Their unique structural and conductive properties have paved the way into the engineering and science field, thus giving researchers and scientists novel ideas on how to develop these nanomaterials and improve them. In this review paper, the structural properties of carbon nanotubes have been discussed along with their synthesis methods like arc discharge, laser ablation, and chemical vapour deposition. The analysis of nanotube-reinforced polymer based on the various scales of modelling like Nano, micro, macro are mentioned. Their applications in various sectors including structural, biomedical, energy are written with careful observations.

**Key Words:** Carbon nanotube (CNT), Synthesis, Analysis, Model, Nanotube, Properties, Representative Volume Element (RVE).

## 1. INTRODUCTION

Carbon nanotubes (CNT) are Nano-dimensional fibers either long or short of cylindrical shape having definite chirality, diameter and are only one atom thick just like graphene sheets. Due to their exceptional mechanical properties, thermal conductivity, and electrical properties [1], they have been a center of attention and have garnered much attention amongst researchers and scientists. The Sp<sup>2</sup> hybridized hexagonal lattice structure mixed with high (stiffness, tensile strength, aspect ratio) and low density make them suitable to be used in nanocomposites and nanostructures.

Owing to their high young's modulus (up to 1 TPa), strength, and size, the distributing pattern in the polymer matrix also defines the mechanical strength of the nanocomposite. By adding a small number of nanotubes (1% by weight) in the matrix, an increase in stiffness by 37-41% and tensile strength by 25% was observed [2]. Due to the complex nature and high cost of experiments involving the nanotubes, modelling and simulations including mathematical models and numerical techniques such as finite element analysis are incorporated for a hassle-free study of their mechanical properties. The addition of these nanotubes in the polymer matrix can affect the mechanical properties of the overall composite, depending on their distribution pattern, size as well as some of their types as mentioned hereafter.

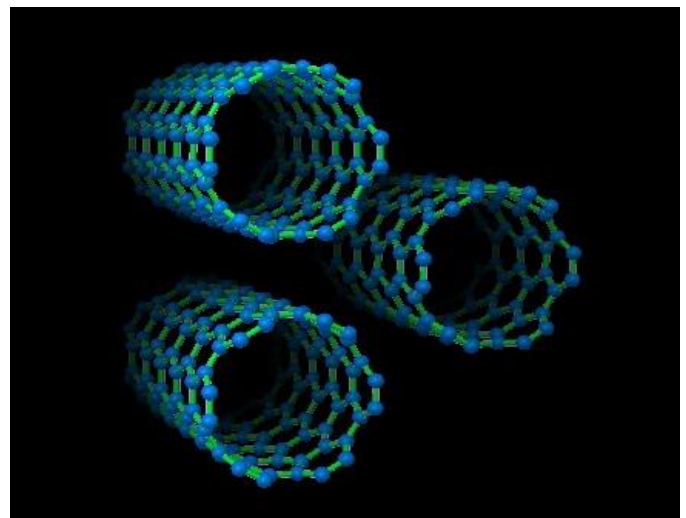

Fig -1: Carbon Nanotubes

### 1.1 Single Wall Carbon Nanotubes (SWCNT)

These nanotubes are the one-dimensional cylindrical allotropes of carbon having only a one-atom-thick wall of carbon sheets rolled into a cylindrical shape, having small diameters of about range (1-2.3) nm and a large aspect ratio (length to diameter ratio). These are generally manufactured by the vapour deposition method.

### 1.2 Double Walled Carbon Nanotube (DWCNT)

These are also one-dimensional materials somewhat analogous to the single-walled nanotubes. The main difference is it consists of two single-walled nanotubes of different diameters co-axially fitted into each other. The outer wall generally protects the inner wall during some synthesis processes. Some optimizations can also be done to the outer nanotube without disturbing the inner nanotube. Certain changes in the chirality and width can be done to determine their conductive properties (semi-conductive/metallic).

### 1.3 Multi-Walled Carbon Nanotube (MWCNT)

The presence of two or more concentric nanotubes of varying diameters makes up a multi-walled carbon nanotube ranging up to 30nm. With higher aspect ratios, electrical conductivity, and an excellent tensile strength, these nanotubes are also chemically stable. The nanotubes in double-walled and multi-walled are bonded to each other by weak Van der Waal forces.

## 2. Synthesis

With the increase in demand for carbon nanotubes in smart composites and the latest breakthroughs in nanofibers used in polymer composites, various synthesis methods of these nanotubes have cropped up over the recent years, since its discovery in 1991 by Iijima [3]. Processes like Arc discharge method, Laser-ablation method, Chemical vapour deposition method (CVD). For large scale nanotubes only CVD is preferred over the other two, as it involves fewer impurities. Some of these methods are discussed below:

### 2.1 Arc Discharge Method

This method involves a closed setup filled with a noble gas like helium at a pressure of about 400 mbar in a vacuumed chamber. Two graphite electrodes are kept at closed proximity (~1-2 mm) to each other, a DC current of 100 A and a voltage of 31-34 kV is passed through these electrodes to obtain a deposition of nanotubes on the cathode with the decay of anode.

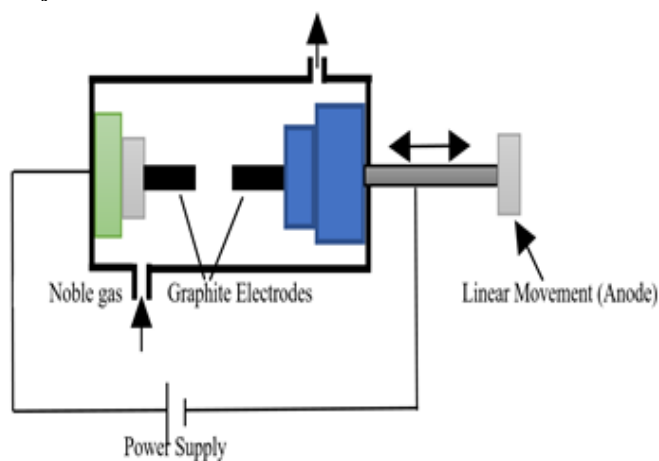

Fig -2: Arc discharge method

Linear movement of the anode is followed to keep the distance between the electrodes constant. The single-walled nanotubes are prepared by using a suitable metallic catalyst [4, 5].

For the processing of the multi-walled nanotubes a heated plasma discharge is used.

### 2.2 Laser Ablation Method

A technique specifically used to synthesize the single-walled nanotubes. In this setup, a laser beam is targeted on a graphite block from where it vaporizes and is deposited at the other end. The temperatures in this method can reach to 1210°C. Various parameters like the intensity of the laser beam, temperatures, and catalyst types can be altered for the required diameter and growth of the nanotubes.

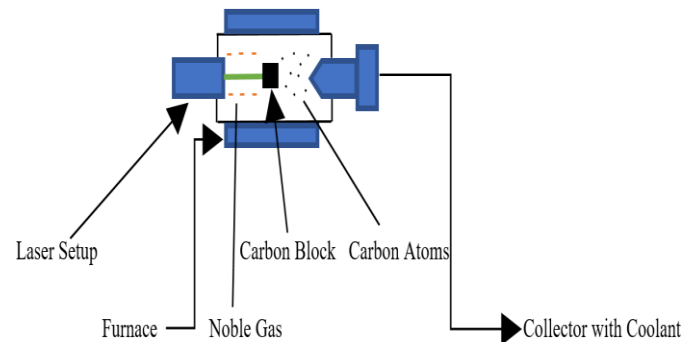

Fig -3: Laser ablation method

### 2.3 Chemical Vapour Deposition Method (CVD)

In this method, metal catalyst particles such as nickel, cobalt, etc. are formed into a membrane, which is heated up to 710°C. Two gases, a combination of an action gas (nitrogen or hydrogen) and a carbon-carrying gas (acetylene or methane, etc.) are exposed into a chamber, to start the growth process of nanotubes.

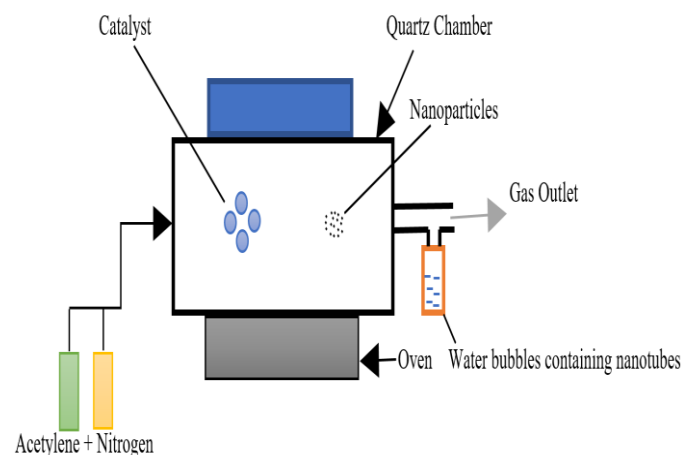

Fig -4: Chemical vapour deposition method

The carbon-carrying gas breaks down and settles at the site of the catalyst membrane, thus forming the nanotubes. It is one of the most commonly used processes for the synthesis of nanotubes.

### 3. Analysis of CNT Reinforced Polymer Composites

As the experimental synthesis of carbon nanotube reinforced polymer composites is complex due to its small-scale dimensions and the use of precision equipment in the fabrication of these nanocomposites. The software analysis of these nanocomposites using the finite element method (FEM) is comparatively easier and the results obtained through this method are somewhat closer to the experimental results, as mentioned in the literature. The use of software like ANSYS, ABAQUS having a dedicated material designer module for designing these types of nanoscale materials. Different multiscale models [6] have been developed to analyze nanotube-reinforced polymers.

#### 3.1 Nanoscale Models

In this type of model, each C-C bond of a hexagonal lattice is treated as a beam element, considering the correlation between the molecular mechanics and the structural mechanics as depicted by Li and Chou [7]. The models based on beam structure are computationally easier than the other models. The results containing the relation between the tube diameter with young's modulus of the CNT are obtained.

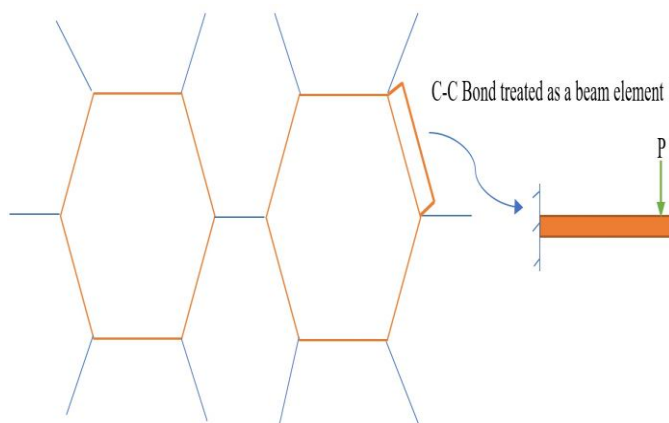

Fig -5: Nanoscale model as a beam element

#### 3.2 Micro-scale Models

These models are developed solely to study the interaction between the nanotube and the surrounding matrix polymers. Generally, a 3D representative volume element (RVE) is used to simulate the model. As the nanotubes are linked with surrounding polymers by the weak Van-der Waal forces and electrostatic interaction [8], in most cases this interphase bonding is neglected and is considered as a perfect bonding. The hexagonal lattice structure of the nanotube is considered as a smooth cylindrical tube (solid model) based on the ease of analysis. The results obtained generally verify the capability of load transfer from matrix to the nanotube fiber concerning the length of the nanotube.

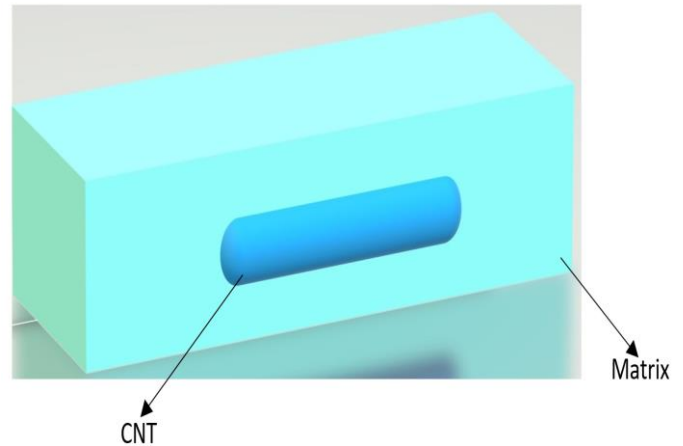

Fig -6: RVE of a micro-scale model

#### 3.3 Macro-scale Models

These models have dimensions in mm. The nanotubes are dispersed in the matrix medium either randomly or are aligned, which impacts the mechanical properties of the overall composite.

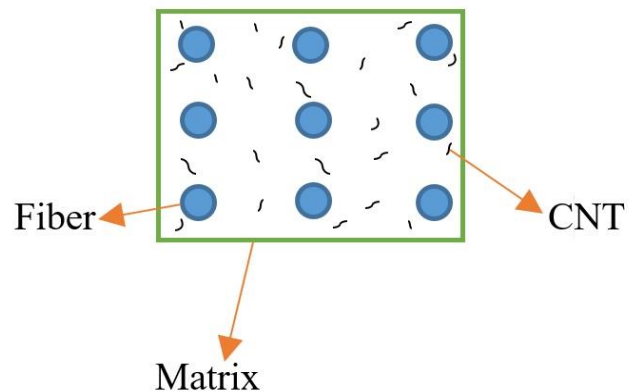

Fig -7: RVE of macroscale model

Generally, the RVE's of the macro-scale models involve two or more equivalent fibers either glass or carbon fiber along with the nanotube fiber also known as hybrid composites.

### 4. APPLICATIONS

- a) **Damage Detection Systems:** Due to the incorporation of composite materials in structures and vehicles has led to the invention of damage sensing units to detect any possible anomaly in any part of the structures. Carbon nanotube has been incorporated as damage sensing either as fuzzy fiber to measure the level of strain in the body [9] or as conductive inter-laminar interfaces [10] to detect variations in electrical resistance. Apart from increasing the properties of the parent composite, it also helps in sensing the damage in stress-concentrated areas.

- b) Biomedical Applications:** The ability of carbon nanotubes to combine with cells of the body, involving no harmful implications as well as the ability to initiate growth and renewal of neurons has made them potentially applicable to be used in biomedical applications.
- c) Fluid Filters:** The anti-bacterial and blocking properties of the nanotubes are being actively used in purifiers and cleaners.
- d) Structures:** Due to their exceptional material properties involving strength and stiffness, carbon nanotube-reinforced polymer composites are being used in a wide variety of structures.
- e) Conductive Electrodes:** The excellent conductive properties of the nanotubes have made them be used as electrodes in batteries and capacitors.

in composite laminates under fatigue loading' *Materials and Design* 160(2018) 1217-1225.

## 5. CONCLUSION

Since the discovery of carbon nanotubes and their exceptional mechanical properties as a nanomaterial and their use as a fiber in polymer composites has created wider applications in structural composites. The alterations in the dimensions or the structure of the nanotubes have yielded improved results in the properties of the composite. Their synthesis has become much easier and efficient due to the recent advancements in the production of these nanomaterials. Due to their application as a fiber in structural composites, in filtering units, as an energy storage component, and in biomedical sectors, the use of these nanomaterials has increased manifolds in past few decades.

## REFERENCES

- [1] Dresselhaus, M.S., Dresselhaus, G., and Saito, R., 'Physics of Carbon nanotubes', *Carbon* 33(7)(1995) 883-891.
- [2] D. Qian, E. C. Dickey, R. Andrews, and T. Rantell, "Load transfer and deformation mechanisms in carbon nanotube-polystyrene composites," *Applied Physics Letters*, 76, 2868-2870 (2000).
- [3] Iijima, S., 'Helical microtubules of graphitic carbon', *Nature* 354(6348)(1991) 56-58.
- [4] Iijima, S.; Ichihashi, T., Single-shell carbon nanotubes of 1-nm diameter. *Nature* 1993, 363, 603-606.
- [5] Bethune, D. S.; Klang, C. H.; De Vries, M. S.; Gorman, G.; Savoy, R.; Vazquez, J.; Beyers, R. Cobalt-catalysed growth of carbon nanotubes with single-atomic-layer walls. *Nature* 1993, 363, 605-607.
- [6] Mahmood M. Shokrieh, Roham Rafiee, 'Stochastic multi-scale modeling of CNT/polymer composites', *Computational Materials Science* 50(2010) 437-446.
- [7] C. Li, T. Chou, *Int. J. Solids Struct.* 40(2003) 2487-2499.
- [8] V. Lordi, N. Yao, *J. Mater. Res.* 15 (12) (2000) 2770-2779.
- [9] J. Sebastian, N. Schehl, M. Bouchard, M. Boehle, L. Li, A. Lagounov, K. Lafdi, 'Health monitoring of structural composites with embedded carbon nanotube coated glass fiber sensors', *CARBON* 66(2014) 191-200.
- [10] Oleksandr G. Kravchenko, Diego Pedrazzoli, Vahab Solouki Bonab, Ica Manas-Zloczower, 'Conductive interlaminar interfaces for structural health monitoring