

Robot Prototype for Disinfection of Surfaces

Disha Deepu¹, Aishwarya Mohan², Alisha Dangat³, Rasika Dhamane⁴, Sadhana Pai⁵

^{1,2,3,4}UG Student, Dept. of Electronics and Telecommunication Engineering, Fr. C. Rodrigues Institute of Technology, Maharashtra, India

⁵ Associate Professor, Dept. of Electronics and Telecommunication Engineering, Fr. C. Rodrigues Institute of Technology, Maharashtra, India

Abstract - The requirements of the working and safety norms demonstrate significant need of increased efficiency and improved working conditions in disinfecting spaces. In view of the current pandemic situation, to fight the battle against the deadliest coronavirus present among us and its spread worldwide, a disinfection system is implemented on robotic platform to ensure thorough sanitization of highly frequented and human contact surfaces by disinfecting them with the help of UV-C rays using Raspberry Pi to ensure that no workers life is at risk.

Key Words: Disinfection, Raspberry-Pi, Robot, Surfaces, UV

1. INTRODUCTION

A special attention is directed for disinfecting outer surface of spaces where human exposure is frequent. The cleaning technologies for space depend on several aspects such as the build-up material, the surface material, and the ambient conditions. The mechanisms and robots related to the studied problem are surveyed and evaluated from the viewpoint of their capability to disinfect outer surfaces and inner surfaces up to some extent. The purpose of this paper is to describe the design and implementation of a Wheeled Robotic Arm providing UV sterilization that destroys any virus, bacteria or micro-organisms in the environment that can be controlled autonomously and manually via Webpage & Android Application. Raspberry Pi-3 Model B, Motor Shield L293D, Ultrasonic Sensor, and Raspberry Pi-camera are the major components used to achieve the goal. With the advancement of technology, robots are getting more attention of researchers to make life of mankind safe, fearless and comfortable. This robot will help speed the cleaning process of contaminated areas. This paper aims at proposing technology which will speed up disinfection work and improve human productivity in a safe environment which is the necessity of the hour.

2. LITERATURE REVIEW

Robotics involves design, construction, operation, and use of robots. The goal of robotics is to design intelligent machines that can help and assist humans in their day-to-day lives and keep everyone safe. The reason robots are used is that it is often cheaper to use them over humans, easier for robots to do some jobs and sometimes the only possible way to accomplish some tasks. Robots can explore inside gas tanks, inside volcanoes, travel places too dangerous for

humans to go where extreme temperatures or contaminated environments exist. For better or worse the robots are going to replace many humans in their jobs, analysts say, and the coronavirus outbreak is speeding up the process. "People usually say they want a human element to their interactions but Covid-19 has changed that, Covid-19 is going to change consumer preference and really open up new opportunities for automation. Companies large and small are expanding how they use robots to increase social distancing and reduce the number of staff that has to physically come to work. Robots are also being used to perform roles workers cannot do at home.

Many elements of robots are built with concept from nature. Construction of the manipulator as the arm of the robot is based totally on human arm. The robot has the potential to manipulate objects such as pick and location operations. It is also capable to function with the aid of itself. The improvement of digital industry robotic device science has been improved increasingly. As one such application, the service robotic with computer imaginative and prescient functionality has been developed recently. Time and man power are crucial constraints for completing commitments in massive levels in this surprisingly growing world. In most common and often held works, the automation plays the required role to store manual effort. Selecting and putting jobs from origin to destination is amongst the most significant and most commonly done tasks. Modern time business has become a growing number of turning closer to computer-based processing usually due to the use of compounded efficiency and standardized quality delivery of end goods. The inconsistency and typically excessive fees of tough automation systems used in the past for automated manufacturing tasks have resulted in a wide-ranging, fully pastime-based use of robot arm designed to perform a multitude of product enhancement in a versatile setting at reduced costs.

In automating the production cycle, use of such Industrial mechanical arm characterizes some of the modern-day traits. Present day mechanical manufacturing arm, furthermore, also demonstrates a mechanical framework and confined-system device design. They focus on basic repetitive work, which appear not to require high precision.

Ultraviolet (UV) is a form of electromagnetic radiation with wavelength from 10 (with a corresponding frequency around 30 PHz) to 400 nm (750 THz), shorter than that of visible light, but longer than X-rays. UV radiation is present in sunlight, and constitutes about 10% of the total electromagnetic radiation output from the Sun. It is also

produced by electric arcs and specialized lights, such as mercury-vapor lamps, tanning lamps, and black lights. Although long-wavelength ultraviolet is not considered an ionizing radiation because its photons lack the energy to ionize atoms, it can cause chemical reactions and causes many substances to glow or fluoresce. Consequently, the chemical and biological effects of UV are greater than simple heating effects, and many practical applications of UV radiation derive from its interactions with organic molecules. Short-wave ultraviolet light damages DNA and sterilizes surfaces with which it comes into contact. For humans, suntan and sunburn are familiar effects of exposure of the skin to UV light, along with an increased risk of skin cancer. The amount of UV light produced by the Sun means that the Earth would not be able to sustain life on dry land if most of that light were not filtered out by the atmosphere. More energetic, shorter-wavelength "extreme" UV below 121 nm ionizes air so strongly that it is absorbed before it reaches the ground. However, ultraviolet light (specifically, UVB) is also responsible for the formation of vitamin D in most land vertebrates, including humans. The UV spectrum, thus, has effects both beneficial and harmful to life.

In [1], P. Chanprakon et al. (2019) propose a UV robot or UV bot for sterilization in an operating or a patient room. The UV bot has three 19.3-watt of UV lamps mounted on top of the UV bot platform covering 360° direction. The UV bot employed an embedded system based on a Raspberry Pi to aid in navigation to avoid obstacles. In addition, the effectiveness of eliminating Staphylococcus Aureus bacteria sample plates located 35 cm away from our UV bot to be within 8 seconds after UV light exposure was tested.

In [2], Akanksha Vyas et al. (2018) propose the development of an automatic floor cleaner. Their aim is to construct a floor cleaner which will be fully automatic providing dry and wet cleaning as well as UV sterilization. The current market is occupied by cleaners with only one or two functionality.

In [3], A. N. W. Qi et al. (2015) propose to design and develop the mechanism for robotic arm for lifting. The robotic arm was designed with four degrees of freedom and programmed to accomplish accurately simple light material lifting task to assist in the production line in any industry. The robotic arm is equipped with 4 servo motors to link the parts and bring arm movement. Arduino, an open-source computer hardware and software is applied to control the robotic arm by driving servo motors to be capable to modify the position. Wireless control was done by using a smart phone with android operating system through a Bluetooth module.

In [5], Manuela Buonabbo et al. (2020) proposed that a direct approach to limit airborne viral transmissions is to inactivate them within a short time of their production. Germicidal ultraviolet light, typically at 254 nm, is effective in this context but, used directly, can be a health hazard to skin and eyes. By contrast, far-UVC light (207–222 nm) efficiently kills pathogens potentially without harm to exposed human tissues. As all human coronaviruses have similar genomic sizes, far-UVC light would be expected to

show similar inactivation efficiency against other human coronaviruses including SARS-CoV-2. Thus while staying within current regulatory dose limits, low-dose-rate far-UVC exposure can potentially safely provide a major reduction in the ambient level of airborne coronaviruses in occupied public locations.

In [10], Aishwarya Padman and Shon J. Das (2020) propose to build up a pick and place robotic arm vehicle which could be controlled using an android application. The android phone and Raspberry Pi board is associated with one another so that the developments can be controlled. The robotic arm is structured out in such a way that it plays out similar action as that of a human hand. Signal is being produced from the Android application to control the robotic arm vehicle either to move ahead, reverse, left or right, which will be further obtained by the Raspberry Pi used. The robotic arm works as indicated by the preset program with the assistance of motors. The motors are the ones which drives the arm part as well the body (chassis). The android application is the main command sector of the robotic arm vehicle. The programming in Raspberry Pi is being developed in Python language and various information given will control the movement.

3. SYSTEM ARCHITECTURE

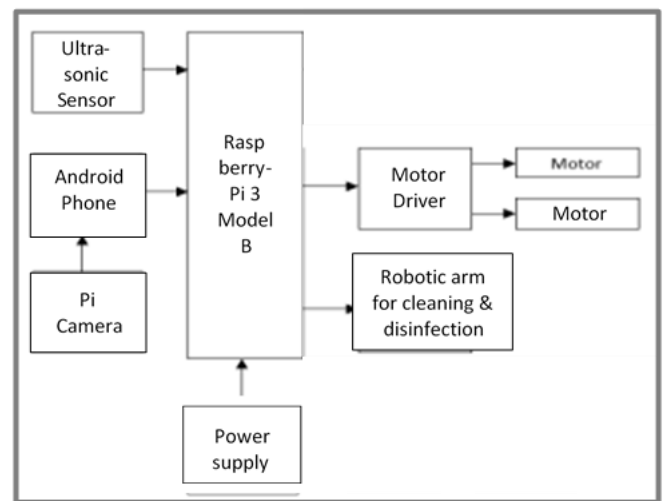

Fig -1: Block Diagram

Fig -1 depicts the block diagram of the complete system. Raspberry Pi is the main component of our project as it is a controller & it will control the function of other components which are connected to it. Robotic arm is connected to pi model where UV wand will be mounted, a type of mechanical Arm which is programmable with similar function to human arm. Motor driver element is connected as a bridge between pi model and motors as we can't connect motor drivers to pi model directly. Pi camera is also connected to pi model via android phone since we are using Wi-Fi & webpages for communication between robot & android phone. Ultrasonic sensors are added to detect the obstacles in the path of the robot so that robot doesn't topple and can be controlled using control buttons on the webpage [1].

4. SYSTEM IMPLEMENTATION

4.1 Hardware

Raspberry Pi

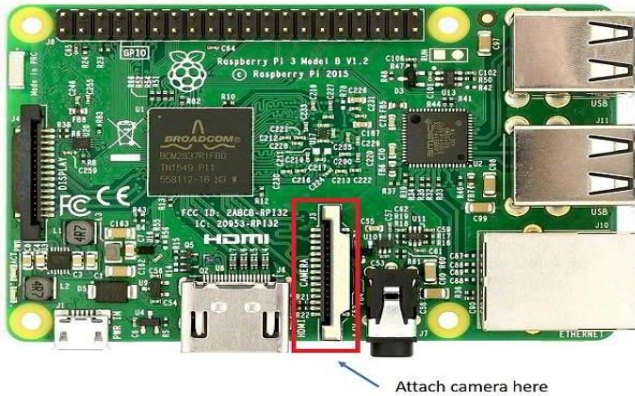

Fig -2: Raspberry Pi

Fig -2 shows GPIO pins being General Purpose Input / Output connector no longer intended to be connected with any direct analysis feature on the Raspberry Pi board. Instead, the GPIO pins are there explicitly for the end user to have access to the board for the functions of attaching other hardware boards, peripherals, LCD display screens, and other hardware devices to the Pi immediately on the board. Quad Core 1.2GHz Broadcom BCM2837 64bit CPU, 1GB RAM, wireless LAN and Bluetooth Low Energy (BLE) on board, Full size HDMI, CSI camera port, DSI display port, Micro SD port are some of its features which were considered suitable for the project [9].

UV Wand



Fig -3: UV Wand

Fig -3 shows a UV-C product called a UV Wand. UV-A and UV-B light can also kill some bacteria and germs, but are mostly ineffective against viruses like SARS-CoV-2. Germicidal UV products can actually change the DNA and RNA of bacteria and viruses, destroying their ability to reproduce. Most UV-C products can inactivate up to 99.9% of pathogens including viruses, bacteria, mold spores, and fungus. Viruses are not technically living organisms, so germicidal UV technically "inactivates" viruses. Since COVID-19 can live on certain surfaces for up to three days and can travel through the air, germicidal UV is a great tool to disinfect air and surfaces. Now, the technology is expanding to include new products that can work for a wide range of

industries, not just hospitals. Similar to the UV-A and UV-B rays from the sun, exposure to UV-C can damage the skin and eyes. It's important to follow strict safety guidelines when the products are operating [5].

Torque Motors



Fig -4: Torque motor

Fig -4 shows a torque motor, which is a type of rotary electric motors which directly converts direct current into mechanical energy. The pace of a DC motor can be handled across a wide range, either by using a varying controlled by changing the current level of its field windings [9].

Robot Base Setup

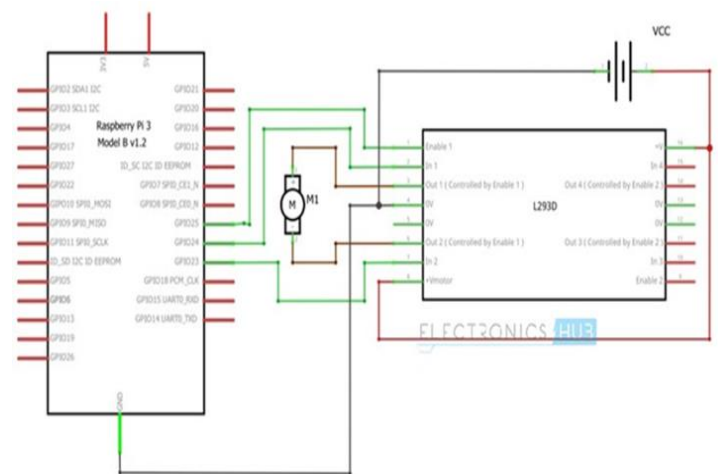

Fig -5: Circuit Diagram of Motor Interfacing with L293D

Fig -5 shows the design of the circuit for controlling a DC motor with Raspberry Pi. First, connect the pins 8 and 16 (VCC2 and VCC1) of L293D to external 5V supply and 12V supply. There are two ground pins on L293D. Connect the ground pin of L293D to GND pin of the Raspberry Pi. Finally, we have the enable and control input pins. Connect the input pin 1 of L293D to GPIO23 of Raspberry Pi. Then connect control input pins 2 to GPIO24 of Raspberry pi. The output pins of motor driver connected to motor that is pin 3 and 6 to the motor [8].

Pi- Camera Setup



Fig -6: Pi camera interfacing with Raspberry Pi

Fig -6 depicts how the Raspberry Pi cam is being used in the project, which is directly connected to the Raspberry Pi port. Hence all of the movement can be figured out through the video streamed on to the Android. Hence, system works based on the command given the user. The whole system works based on Wi-Fi. The Raspberry Pi accepts the commands from the Android Application through internet connection. The Wi-fi can be enabled in the Raspberry Pi and need to be connected with the same network as that of which phone is connected [3].

Robot Arm and Chassis



Fig -7: Robot Arm and Chassis

Fig.2. shows the chassis part which is similar to that of a four-wheeler platform. It comprises of wheels, torque motors and a platform. The chassis is made up of a metal body of dimensions 24cm length & 7.5cm breadth assembled with the wheels of diameter 6.5cm along with four 12V DC Motors which are connected to each wheel of the chassis [2].

The chassis can move freely in the direction the user wants to, that are forward, backward, left and right. Motors

are the ones that play a major role in the system [6]. All of it is connected to the specified GPIO pins in Raspberry Pi via L298N Motor Driver. The robotic arm has three parts, out of which one is fixed and rest two are movable. These parts are linked with screws and nuts. Two more DC motors are used at the joints of the arm for the movement. Here, the hardware setup is ready. Based on the predefined commands the motors work which are connected to the GPIO pins and accordingly the system does the works [4].

4.2 Software

Python on Raspbian

Python is an interpreted high-level general-purpose programming language. Python's design philosophy emphasizes code readability with its notable use of significant indentation. Its language constructs as well as its object-oriented approach aim to help programmers write clear, logical code for small and large-scale projects. Raspbian is a free operating system based on Debian optimized for the Raspberry Pi hardware. An operating system is the set of basic programs and utilities that makes Raspberry Pi run [10].

HTML (Hyper Text Markup Language)

HTML stands for Hyper Text Markup Language. HTML is the standard markup language for creating Web pages. HTML describes the structure of a Web page. HTML consists of a series of elements. HTML elements tell the browser how to display the content [11].

Pi Camera Video Streaming and Robot Controls

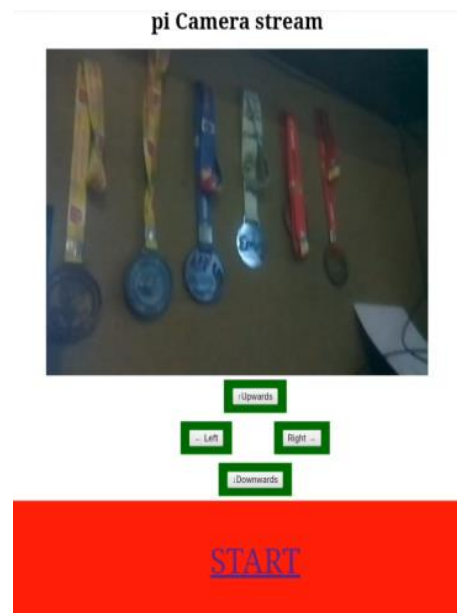

Fig -8: Webpage for Robot Control with Video Streaming

Fig -8 shows the Android Application developed for this system. Each of these buttons are being specified with certain features. First of all, the connection is being established with the Raspberry Pi using Wi-Fi facility. The IP address of the Raspberry Pi need to be entered in the browser section for the establishment of connection.

Webpage contains video streamed real-time, arrow buttons for controlling the motion of robot and start button for initiating disinfection action. PiCamera v.1.3 is used as camera for the robot. Video streaming code was written using existing APIs of PiCamera class (source code).

URL that was generated for the webpage is http://<Raspberry_Pi_IP_Address>:8000 which is to be used to access the control page. The Raspberry Pi IP address is unique for each Pi module. This will prevent the robot to be controlled by someone other than the person assigned for the task. Also no overlap between different robots of the same kind will occur. The Real time video can be obtained on the screen so that we could get to know the current position of the system. The forward, reverse, left and right buttons are being used for the movement of the base part. The start button is being used to start disinfection action [7].

5. RESULTS

The objective of the work presented in this paper is to develop a device which will help in the disinfection of surface. This paper mainly contains two parts hardware and software. In which the hardware part contains a robotic arm, Raspberry -pi and interfacing camera which captures the images of the surface which is processed through the algorithm. The robot can work in manual mode. This is done in order to achieve proper sanitization and accuracy of the final results. Also, due to this approach it becomes easier to detect whether the micro-organisms are present on the surface. This approach makes it easier to disinfect in public places. This setup serves as a useful aid for hospitals and crowded places for first level of disinfection and sanitization. Disinfecting the surfaces by UV rays using Raspberry Pi controller will help to reduce the risk of lives of individuals.

6. CONCLUSIONS

The study of different disinfectant systems led us to identify our choice on the development of a disinfection robot. It is not an autonomous device and has to be controlled manually. The lamps integrated into the robot and its mobility can deactivate microorganisms in a specific time interval. Based on integrated sensors, and cameras, the device is of high utility. Robot shuts down when humans are around to protect them from the harmful effects of UVC. The future scope for this project can be making this robot autonomously driven so that even less human intervention is required and making the robot base more resilient to rough terrain for smoother operation.

REFERENCES

- [1] P. Chanprakon, T. Sae-Ong, P. Hannanta-Anan, "An Ultraviolet Sterilization Robot for Disinfection", 2019 5th International Conference on Engineering, Applied Sciences and Technology (ICEAST).
- [2] A. Vyas, S. Chourasia, S. Antapurkar, R. Prasad, "Arduino based dry and wet automatic cleaner", Communication, Integrated Networks and Signal Processing-CINSP 2018.
- [3] Vatsal Shah, "Floor cleaning robot with mobile app," unpublished.
- [4] A.N.W.Qi, K.L.Voon, M.A. Ismail, N.Mustafa, M.H.Ismail, "Design and Development of a Mechanism of Robotic Arm for Lifting", 2nd Integrated Design Project Conference (IDPC) 2015.
- [5] Manuela Buonabbo, David Welch, Igor Shuryak, David Brenner, "UVC light efficiently and safely inactivates airborne human coronaviruses", March 10, 2020[Online]. Accessed on: June 20, 2020. Available: <https://rdcu.be/b845N>
- [6] Digital guide for Fusion 360 for Robotics, v1.1. Learn Robotics, Phoenix, AZ, USA, 2020.
- [7] "Video Streaming with Raspberry Pi". Accessed on: Aug 1, 2020[Online]. Available: <https://randomnerdtutorials.com/video-streaming-with-raspberry-pi-camera/#more-41863>
- [8] "Control a DC motor with L298N and Raspberry Pi", Feb 9, 2018. Accessed on: July 3, 2020[Online]. Available: <https://www.electronicshub.org/raspberry-pi-l298n-interface-tutorial-control-dc-motor-l298n-raspberry-pi>
- [9] Aiswarya Padman, Shon.J.Das, "Android Application Based Robotic Arm Control Using Raspberry Pi", International Journal of Scientific & Engineering Research (IJSER), Vol 7, Issue 22, July-2020.
- [10] "Operating System Images", Jan 10, 2012. Accessed on June 12, 2020[Online]. Available: <https://www.raspberrypi.org/software/operating-systems/>
- [11] "HTML for beginners the easy way", Feb 24 2015. Accessed on July 24, 2020[Online]. Available: <https://html.com/>