

Oxy Hydrogen Gas Generator Design and Development for SI Engine

Anuprita Arun Ingle

Dept. of Mechanical Engineering, K.K. Wagh Institute of Engineering Education and Research, India

Abstract - Several innovative technologies are now available to help cut fuel consumption, pollutants, and increase brake thermal efficiency. The use of hydrogen in internal combustion engines, which may be found in water and air, is one of these technologies. The goal of this study is to see how utilizing hydroxy gas affects the performance of a gasoline engine. For optimal HHO gas productivity per input power, an HHO dry cell will be designed, built, and optimized. The important parameters that influence the rate of HHO generation were taken into account. A gasoline engine's performance will be compared with and without the HHO gas. With a rise in HHO, the engine brake efficiency should improve, the thermal efficiency should improve, the specific fuel consumption for the engine should drop, and the temperature of the exhaust should decrease. With an increase in HHO, HC and CO emissions should decrease.

Key Words: fuel consumption, Hydrogen, hydroxygas, HHO dry cell, gasoline engine, specific fuel consumption.

1.INTRODUCTION

Currently most of our vehicles runs on fossil fuels which produces very harmful gasses like CO, NOx, HC, etc. in the form of smoke, which are creating lots of health problems as well as the reason for global warming.

The sooner we decrease our reliance on fossil fuels, and develop a new energy sources, the better it is. Whether you believe in climate change or not but the benefits extend beyond by just the reduction in greenhouse gas emissions and the supply of oil and gas will inevitably dry.

Tesla pioneered our greatest hope in this space to date with the development and popularization of battery technology. But as we have seen they are struggling to meet the enormous half a million pre-orders for the model 3. Elon Musk self-proclaimed production cell has resulted in delay after delay. The demand for lithium-ion battery technology is simply growing faster than the supply of lithium can satisfy. So we need a multi-faceted approach to solve this problem. It is difficult to replace all the IC engines vehicles with electric vehicles with small transition time frame considering all practical factors. So researchers found alternative solutions that would not require a dramatic modification in engines design. Among such solutions is using oxy hydrogen (HHO) as a secondary fuel to enhance engine efficiency and reduce harmful pollutants and we can have some breathing time for complete transition to electric vehicles.

Production of HHO: A pure stoichiometric mixture for oxy hydrogen is obtained by water electrolysis, which uses an electric current to dissociate the water molecules. electrolysis: $2 H_2O \rightarrow 2 H_2 + O_2$

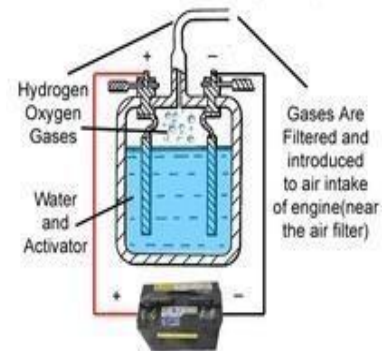

Fig -1 HHO generator

In the year 1800, William Nicholson was the first to decompose water in this way. Separation of water into a mixture of hydrogen and oxygen gases has recently received a lot of attention.

Yull Brown began these investigations in 1977 using electrolyzes, and the resulting gas is known as "Brown's gas" or HHO. As a fuel, HHO gas has qualities that are similar to hydrogen. Hydrogen is the lightest of all the elements, odorless, colorless, nontoxic, environmentally friendly, and extremely combustible. Hydrogen is 100% renewable, recyclable, and non-polluting, with a flammability range of 4% to 75% in air and a low ignition energy of 0.02 mJ. High flame speed and diffusivity increase mixture homogeneity and rapid ignition auto ignition temperature 585 C specific energy content 142.18 MJ/kg as higher heating value (HHO), 120.21MJ/kg as lower heating value (LHV).

There are two types of cell used in HHO generator, they are as follows

A. Wet cell

B. Dry cell

A. wet cell:

It is made up of a container, anode and cathode plates (Electrodes plate), electrolyte, and an HHO gas outlet pipe. Cell stack refers to the arrangement of these plates in an alternate order. The electrolyte (water and KOH/NaOH) is immersed in this cell stack.

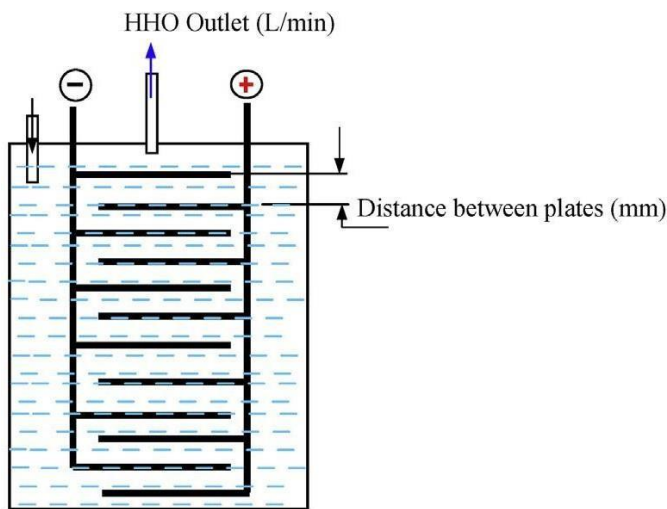

Fig 2- Wet cell [1]

The electrode is then supplied power, and through the electrolysis process, an HHO bubble is produced, which is then expelled through the HHO gas output pipe.

B. Dry cell :

End plate, electrode plates, soft clear PVC spacer rings, electrolyte, gas outlet, water inlet valve, and other components are included. The cell is made up of electrode plates that are placed in an alternating pattern with a gasket in between. Two holes are bored through the entire structure for water intake, outlet, and gas outlet. The plates are not submerged in electrolyte; instead, water circulates across them, giving rise to the term "dry cell." The HHO gas is then created and removed from the gas outlet by an electrolysis procedure.

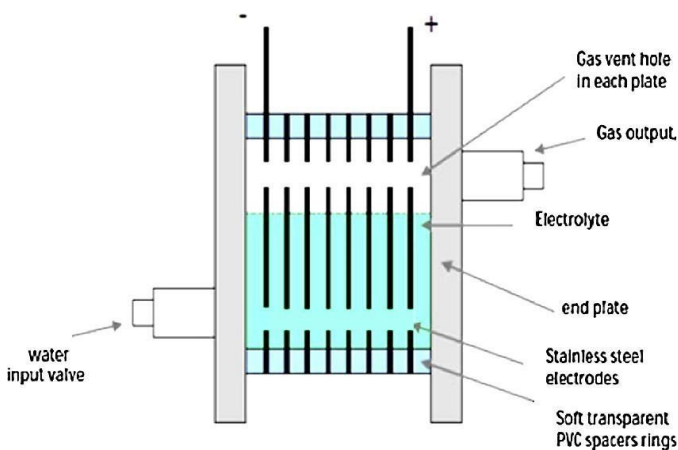

Fig 3 – Dry cell [2]

2. PROBLEM STATEMENT

The globe is facing numerous issues as a result of pollution, which causes serious health issues (asthma, lung cancer, breathing problems, and so on) as well as contributing to global warming. One of the major sources of pollution is CO, NOx, and HC emissions from cars that run on fossil fuels.

Electric vehicles offer a better solution to this problem, but they require lithium-ion batteries, and the demand for lithium-ion batteries is simply outpacing the availability of lithium. To overcome this challenge, we'll need to use a multi-pronged strategy. Considering all practices, replacing all IC engines vehicles with electric vehicles with a short transition time frame is difficult. So use of oxy hydrogen in IC engine will reduce emissions and we can have some time for complete transition to electric vehicles.

1.2 OBJECTIVE The proposed project has a vast scope of development in

- To reduce the harmful emission (CO, HC,CO₂) of gasoline engines which are produced due to incomplete combustion .
- To increase break thermal efficiency of an SI engine.
- To reduce specific fuel consumption of SI engine.
- To maximize fuel combustion in SI engine.
- To study knocking effect with variation of HHO injected in SI engine.

1.3 SCOPE

Electrolysis can be used to produce HHO, which is a simple method. We can store this gas in a separate tank to give it to the IC engine, but because it is a highly flammable gas, it can be dangerous in the event of an accident, so we can design a compact HHO generator that operates on the electrolysis concept and can be used to produce on-board HHO. It is an alternate approach that does not necessitate a significant change in IC engine design, therefore using HHO as a supplementary fuel for traditional internal combustion engine cars is a viable option for reducing greenhouse gas emissions and improving engine efficiency.

1.4 METHODOLOGY

Water electrolysis, which utilizes an electric current to separate the water molecules, can produce a pure stoichiometric mixture of oxy hydrogen:

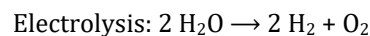

Below are the reactions that take place at the cathode and anode. Reduction reactions take place in the negatively charged cathode, with electrons (e⁻) from the cathode being delivered to hydrogen cations to generate hydrogen gas.

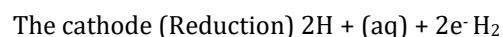

At the positively charged anode, an oxidation reaction occurs, generating oxygen gas and giving electrons to the cathode to complete the circuit. Anode (Oxidation) Reaction: $2\text{H}_2\text{O}(\text{l}) - \text{O}_2(\text{g}) + 4\text{H}^+(\text{aq}) + 4\text{e}^-$

The same overall decomposition of water into oxygen and hydrogen is given in the reaction below.

Overall Reaction: $2\text{H}_2\text{O}(\text{l}) \rightarrow 2\text{H}_2(\text{g}) + \text{O}_2(\text{g})$

We use this HHO Gas, "perfect fuel" as an ADDITIVE gas to supplement the diesel or petrol fuel inside the engine and make it burn better and hence prevent the huge combustion losses inside the engine

2. LITERATURE REVIEW

Ammar A. Al-Rousan et.al^[1] and colleagues Controlling pollution from oil burning is a serious challenge for scientists all over the world. To reduce emissions and accelerate the combustion reaction toward stoichiometric state, a blend of HHO has been injected to the combustion elements. The HHO fuel generation unit, which uses an electrolysis method, was conceived and manufactured with the flexibility to change the distance between the anode and cathode plates, and it was integrated into the Honda G 200. (197 cc single cylinder engine). The distance between the plates was varied between 3, 5, 7, and 10 mm. Tests show that combining HHO, air, and fuel improves engine performance and emissions. The emission tests were carried out while maintaining the electrolyte concentration and temperature by altering the engine speed. The results reveal that the space between cell plates has a significant impact on improving combustion characteristics. At different operating speeds, the maximum produced power and minimum fuel consumption were related with the case of 10 mm cathode anode plates distance, where hydrocarbons (HCs) and carbon monoxide emissions were reduced to nearly 40%. The 5 mm gap instance, on the other hand, has the greatest influence on emission reduction.

Ammar A. Al-Rousan et.al^[2] The current study suggests the creation of a novel device that attaches to the engine and allows an HHO production system to be integrated with a gasoline engine. Experiments were carried out on a 197cc single-cylinder engine (Honda G 200). specs of the engine Maximum Torque 1.06 kg-m/2500 rpm, Bore stroke 67 56, Displacement 197 cm³, Compression Power Ratio 6:5:1, Bore stroke 67 56, Displacement 197 cm³, Compression Power Ratio 6:5:1, Bore stroke 67 56, Displacement 197 cm³, Compression Power Ratio 6:5:1, Fuel Tank Capacity: 3.5 liters, Oil Tank Capacity: 0.7 liters, Dimensions: 337 375 425 mm, Dry Weight: 15 kg The generator is powered by a wet cell. In this experiment, Type B and Type C cells were employed. The Type B cell is made up of one square meter spiraling electrolyte plates (316L stainless steel) set inside a Plexiglas box with all of the necessary connectors and

pipework. The cell's inputs are distilled water and sodium bicarbonate, which serve as the electrolyte. Stainless Steel grade 302 or 304 is utilized for the cathode due to experience, however grade 316L is required for the anode. The cell was created with an 8-liter capacity. Type (C) cells are 12 times the size of type (B) cells. Because the piston is pushed down and out of sequence by the burst of gas fumes, this procedure is inefficient. It goes into reverse a little too soon, causing a "knocking" noise and producing less power. Without knocking, the new mixture (air, gasoline, and HHO) has a chance to change into mechanical torque (rotary push). The effect of the FC on break efficiency, which revealed a 3 percent rise for Cell B and an 8 percent increase for Cell C, exhibits a similar pattern for the thermal efficiency. As a result of the FC, the exhaust temperature has decreased, indicating better combustion and cleaner emissions.

Balaji Subramanian et. al^[3] This document provides an overview of key characteristics and strategies for manufacturing HHO gas. Thermodynamics and chemical kinetics of electrolysis processes are explored in detail. The design and operating parameters for increasing the rate of gas production are identified. The injection of HHO gas boosts engine torque, power, and thermal efficiency while concurrently reducing NO_x, CO, HC, and CO₂ production. Global warming, acid rain, and other health difficulties are some of the negative consequences of these pollutants. The rate of electrolysis is proportional to the cell's current density. As a fuel, HHO gas has qualities that are similar to hydrogen. The ionization energy of hydrogen, which is roughly 13.6 V, is colorless and odorless. Under atmospheric circumstances, it has a liquid-to-gas expansion ratio of 1:848. -259.14 C and 252.87 C are the melting and boiling points, respectively. In air, the flammability range is 4-75 percent, the flash point is -253 degrees Celsius, and the adiabatic flame temperature is 2107 degrees Celsius. The electrolytic cell was introduced in two different designs. Two plate electrodes were immersed in a KOH solution in water in the first kind. Water's electrical conductivity is increased when KOH is added. Because of its stability and compatibility with metallic components, KOH is favored over NaHCO₃. KOH, on the other hand, is caustic and deadly if not handled properly. The second design had numerous electrodes, effectively producing a series of cells. In comparison to the earlier design, this required less electric current. Brown also utilized a flash-back arrester to keep the burner flame from returning to the electrolytic cell. He suggested using direct current rather than alternating current because the former had a lower electrical impedance. If the electrolyte level dropped below a certain level, a circuit breaker and maker

were installed to stop and restart the process. Separate pipes and a suction-actuated valve delivered hydrogen and oxygen to the engine intake, where they mixed just before entering the cylinders. to carry out electrolysis using the power generated by a PV (photovoltaic panel) module with 36 polycrystalline silicon cells and a nominal current of 2.87 A and voltage of 17.39 V. When the electrolyte temperature was increased from 300 K to 340 K, the rate of hydrogen production more than doubled. The hydrogen generation rate was increased by roughly 5 times by increasing the content of NaOH electrolyte from 2 g/l to 28 g/l. Production efficiency: The electrolyzer's HHO generating efficiency is now in the region of 40-70 percent. Increases in current density, operating pressure, temperature, electrolyte solution conductivity, electrode conditioning, and other factors can all help to enhance efficiency.

3. FUNDAMENTALS OF HHO GENERATOR

3.1. Properties of HHO

Oxy-Hydrogen is a molecularly and magnetically linked enhanced combination of hydrogen and oxygen. Hydrogen has a flame speed that is nine times that of petrol and six times that of a gasoline-air mixture. When Oxy-Hydrogen gas is between 4 percent and 94 percent hydrogen by volume, it can burn at normal temperature and pressure. The density of oxygen-hydrogen gas is quite low.

Table 1: Properties of HHO and Diesel.

Property	Diesel	Hydrogen	Petrol
Molar Mass (g/kmol)	200	2.02	114.232
Density(kg/m ³)	840	0.082	748.9
Stoichiometric air/fuel weight	14.7	34.3	12
Auto ignition temperature oC	254-285	585	280
Laminar flame speed (cm/s)	128	230	135
Lower heating value (MJ/kg)	42.61	120.21	44.14
Higher heating value (MJ/kg)	45.58	142.18	46.32

Hydrogen flames are extremely clean, producing almost no soot. A flame is visible because of the soot produced by most fuels. Furthermore, a hydrogen flame emits a lot of energy in the ultraviolet range, rather than the infrared or visible ranges of the light spectrum. When HHO is burned, it emits no carbon dioxide or other pollutants into the atmosphere. The amount of heat energy released is unaffected by the manner of combustion, however flame temperature changes.

3.2. HHO GENERATOR

3.2.1. System Description

HHO generator used in this study is shown in Fig 4. It consists of separation tank (1) which supplies the HHO cell (2) with continuous flow of water to prevent the increase in the temperature inside the cell and to provide continuous hydrogen generation. Oxygen–hydrogen mixture generated from the dry cell will be back to the top of the tank with some water droplets [2]

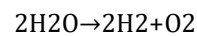

Water droplets will separate and fall to the bottom of the tank with the rest of the water, while hydrogen and oxygen gases are directed to the engine intake manifold. The HHO flow rate was measured by calculating the water displacement per time according to the setup shown in Fig 4. The HHO gas leaves the separation tank and flows into the water open pool (4) pushing the water down of the inverted graduated cylinder (3). The volume of gas collected in the graduated cylinder per unit of time was measured as the HHO flow rate.

Therefore, the cell productivity can be calculated from the following equation:

$$\text{HHO productivity} = \text{volume/time}$$

3.2.2. HHO Separation Tank

The HHO separation tank and its components are shown in Fig 4. It was constructed from 3.5 in PVC pipe (1) with a capacity of 2.2 L. A standard 4 in PVC end caps (2) were used to seal the top and bottom. A 0.5 in PVC ball valve (3) was used to refill the tank with Distilled water with dissolved catalyst. Hoses were used for water inlet (4) and HHO gas outlet from the cell, the condensed water and dissolved catalyst are carried to the cell through outlet (5) and HHO gas outlet (6) to the engine. It is equipped by a Pressure gauge (7) with vacuum range 0–1 bar and a spring loaded vacuum breaker.[2]

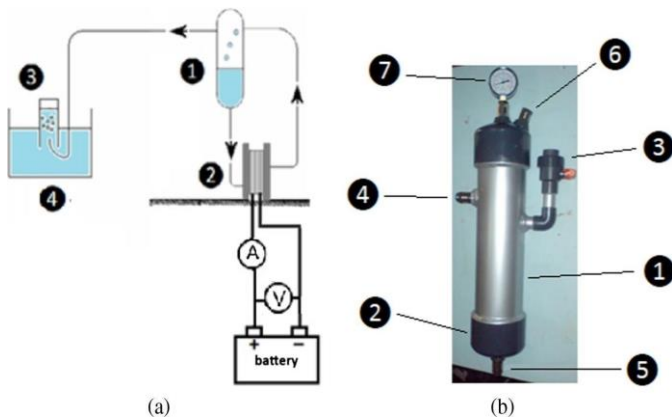

Fig. 4- Schematic diagram of HHO gas generation system. [2]

3.2.3. HHO Dry Cell

The electrodes were made of stainless steel tumblers. There are 16 electrodes with a thickness of 16200.2 cm, constructed in the alternate form (+, 2N, -), where (+) represents the positive electrode, (N) represents the neutral electrode, and (-) represents the negative electrode, as illustrated in Fig 5. Amperage goes from the negative battery connection to the engine battery and then to the positive terminal via the neutral plates. For HHO production, neutrals lower plate voltage, share the same amperage, and enhance surface area. Rubber gaskets were used to keep the space between neighbouring tumblers to 1 mm. In addition, acrylic cover panels with a thickness of 20241 cm were used to provide a visual indicator of the electrolyte level. HHO cell is supplied by electrical energy from the engine battery which is recharged by the engine alternator. The cell productivity was tested without being connected to the engine with 2 different catalysts, KOH and NaOH, to find the best electrolyte with best concentration experimentally. The calculation was done based on the following equation:

- $m_{H_2} = V / (V / K_{mole}) \times M$

V: Hydrogen volume collected = 1/9 displaced volume of the cylinder
 $3.V / K_{mole}$: Volume occupied by one kmole
 $= 22.4 \text{ m}^3 / K_{mole}$
 M: Molecular weight of hydrogen = 2

- Energy gained = $m_{H_2} \times LHV_{H_2}$
- $LHV_{H_2} = 121000 \text{ KJ/kg}$
- Energy consumed = volt \times ampere \times time
- HHO cell efficiency = energy gained / energy consumed

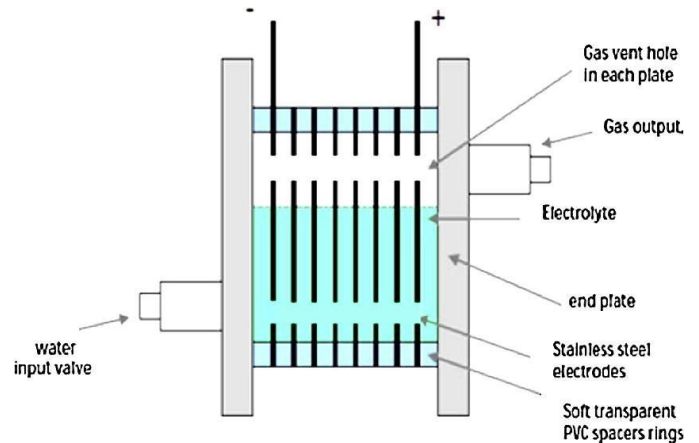

Fig.5 -A schematic diagram of HHO cell [2]

3.3. HHO IN COMBUSTION PROCESS

3.3.1. Introducing HHO in Gasoline Engine

The engine and combustion cycle do not need to be modified in any way to accept the HHO addition in the combustion process. To accommodate HHO in the system, only safety procedures and safeguards must be performed.

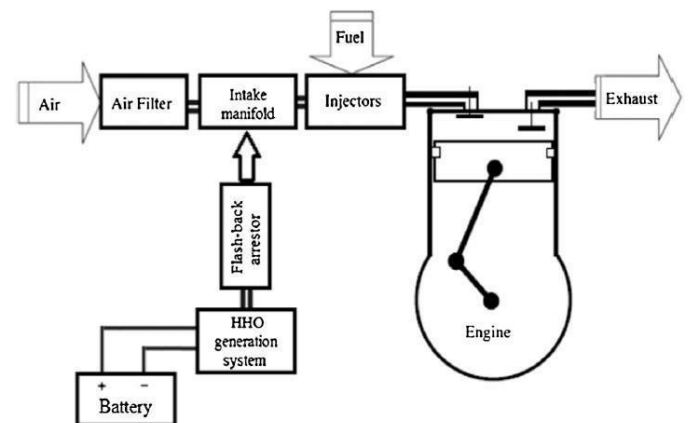

Fig 6 - Schematic illustration of HHO system with safety components installed on engine [2]

3.4. Significant Parameters.

• General design and constructional parameters of HHO generator.

Generally, HHO dry generator is composed of metal plates, stainless steel is preferred due to its good electrical, thermal and physical properties, specifically stainless steel 316L is used in this study, with certain numbers and dimensions determined according to the design and the application. Stainless steel is anticorrosive metal with melting point 1375-1400°C, density is 7.96 g/cm³, and thermal conductivity 16.3 W/m K.

The plates are connected to the electric DC power supply so that one plate has a positive charge (anode), one plate has a negative charge (cathode), and the rest are neutral for each stack generator. The number of neutral plates is decided by the design in order to distribute the source voltage evenly among cells of suitable size. With the help of a rubber gasket, every two successive plates form a closed chamber. The rubber gaskets ensure that any plate that touches another plate is properly sealed, preventing water and gas from entering the generator. Rubber has a thickness tolerance under pressure of 3mm, which is sufficient to provide a good current resistance and sufficient space for the HHO gas to exit freely in the desired direction.

Lower tiny holes in the plates equalize the water level in the cells and allow electrons to flow under voltage drop with minimal friction and heat generation. There are also higher big holes that allow the gas to vent; these holes are in the topmost position to enhance the surface area of contact with water and speed the gas out.

Generator has accessories: Bolts, washers, nuts, fittings, bubbler, connectors, non-return valve, hoses, and tank, two acrylic end cover plates with a thickness of 12mm, one with an inlet water hole and the other with an output gas hole, bolts, washers, nuts, fittings, bubbler, connectors, non-return valve, hoses, and tank The tank ensures that electrolyte is continuously fed to the generator, ensuring that it is kept cold. A bubbler is a container that is partially filled with water and fed with HHO gas, which must rise through the water before continuing its journey. The HHO bubbler is 210mm tall and 38.1mm in diameter. The bubbler is necessary for drying and purifying HHO gas from water vapour before it reaches the electrolyzer, as well as preventing backfires from reaching the electrolyzer. Non-return valve between the electrolyzer and bubbler is a safety essential in the backfire case.

• **The parameters that control the cell's performance.**

The dry cell can be utilised in a variety of engines and vehicles, including gasoline and diesel engines. It's also suitable for use in power generators. The dry cell produces HHO gas, and the rate of gas production can be controlled by adjusting the cell output.

The operating voltage and amperage, the quantity and area of stainless steel plates, cell stacks, electrolyte concentration, and electrode spacing are all variables that might influence this process.

The number of cells and stacks are decided based on the required volume of HHO gas and the available electric power supply, as well as the effective area of the plates.

Cell voltage is directly proportional to the number of cells and the electrolyte content. The source voltage divided by

the number of cells yields the voltage of each cell. When calculating cell amperage, the temperature difference between plates and the operation cell must be taken into account.

Because pure water has a high resistance to current flow by default, it must be reduced by adding a particular amount of electrolytes.

The concentration of the electrolyte in water highly affect on the cell amperage determination. During the operation, if the electrolyte concentration slight increases due to heat generation consequently the current increases in response.

The quantity of HHO gas depends on the water efficiency to pass the current and the amount of current succeeded to travel through the plate surface area.

Parameter	Effect on	Description
Material of Electrode plates	HHO Production rate	Stainless steel 316L grade is found appropriate for HHO production.
Thickness of Electrode plates	HHO Production rate	Thicker plate extend the life of the plates. Over time the plates get thinner. The plates are to stay perfectly aligned, parallel, with even spacing all around for HHO production.
Surface area of Electrode plates	HHO Production rate	Surface area of plate is directly proportional to HHO production rate.
	HHO Production rate	Number of plates is directly proportional to HHO production rate.
	Power consumption	Number of plates is directly proportional to power consumption.
	Cell temperature	Number of plates is directly proportional to cell temperature.

Parameter	Effect on	Description
Gap Between Electrode Plates	HHO Production rate	Decrease in gap between the plates increase gas production but not less than 1mm because gap less than 1mm will not allow produced HHO gas to escape.
Catalyst	HHO Production rate	Catalyst enhances HHO production. Salt causes plates to corrode. Sodium Hydroxide and Potassium Hydroxide are best catalyst proven.
Amount of Catalyst.	HHO Production rate	The gas production increases with catalyst concentration until the limit 28% (weight). Subsequently any increase in the concentration produces a reduction in gas production.
Spacer Thickness.	HHO Production rate	Spacer thickness should be small but not too small. As too small thickness will not allow water to flow and too large thickness will increase resistance to current flow which in return decrease HHO production.
HHO Gas	Engine performance	Spacer thickness should be small but not too small. As too small thickness will not allow water to flow and too large thickness will increase resistance to current flow which in return decrease HHO production.
	Exhaust	Temperature of exhaust decrease with increase in

		HHO, HC and CO emissions decreases
--	--	------------------------------------

3.5. PROPOSED LAYOUT

The proposed layout of the system is as show in the following fig. 7. Various components of the system are as follows

- I. Engine
- II. HHO generator
- III. Injector
- IV. Intake air manifold
- V. Air filter
- VI. Flash-back aresstor
- VII. Battery

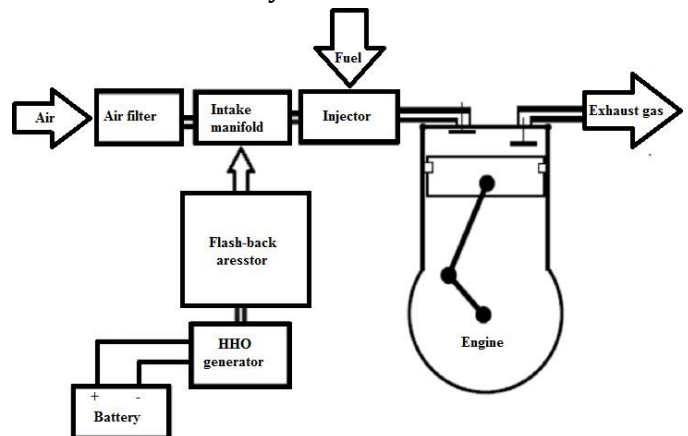

Fig no 7- proposed layout of the HHO system

3.6. CALCULATIONS

From research paper relation between HHO production and size of plate is not specifically mentioned so we will take surface area of square plate from a research paper and we will convert it for circular plate.

Dimensions of square plate : $140 \times 100 \times 1$ mm²

$$\begin{aligned}
 \text{Area} &= b \times d \\
 &= 140 \times 100 \\
 &= 14000 \text{ mm}^2
 \end{aligned}$$

By keeping area same we will calculate diameter for circular plate.

$$A = (\pi / 4) \times D^2$$

$$14000 = (\pi / 4) \times D^2$$

$$D^2 = 133.51 \approx 134 \text{ mm}$$

4. DESIGN DEVELOPMENT

Design 1 is developed first according to above calculations. In this we use casing with threads which will work as casing as well as tightens plates so to avoid any water leakage and holds all plates together. It is totally a new approach than the designs which uses square plate and uses conventional nut and bolt to hold the whole assembly together. When electrons flow through a material it consumes more energy to change its direction in 90 degrees, so to avoid that and increase system efficiency we chose circular shape for the design

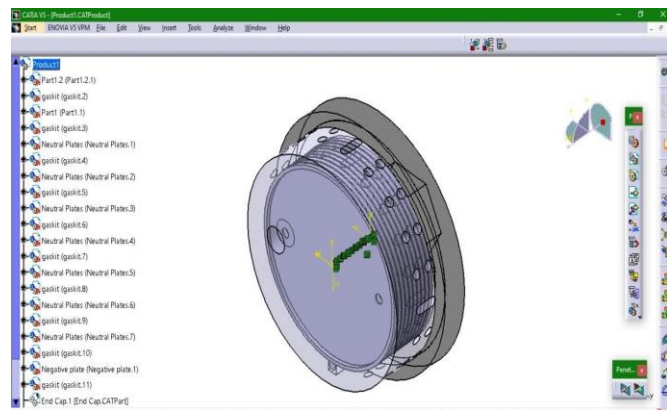

Fig no 8: Design 1

Parts of design 1 are as follows

4.1.1. Neutral plate

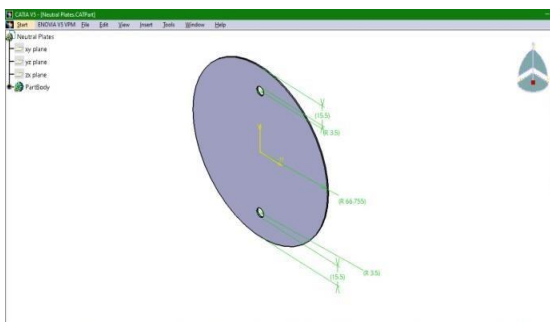

Fig no 9: neutral plate

4.1.2. Anode and cathode plate

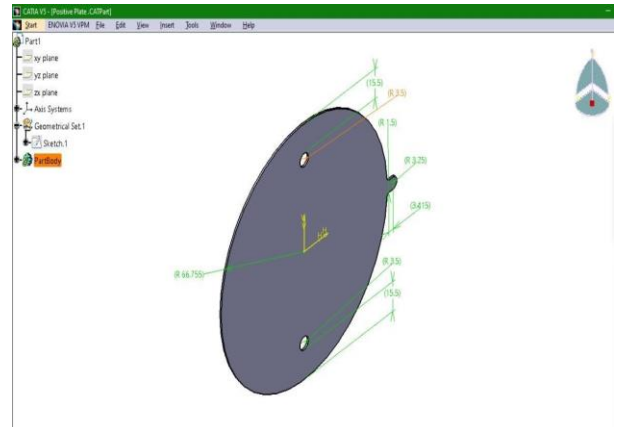

Fig no 10: Anode and cathode plate

4.1.3. Gasket

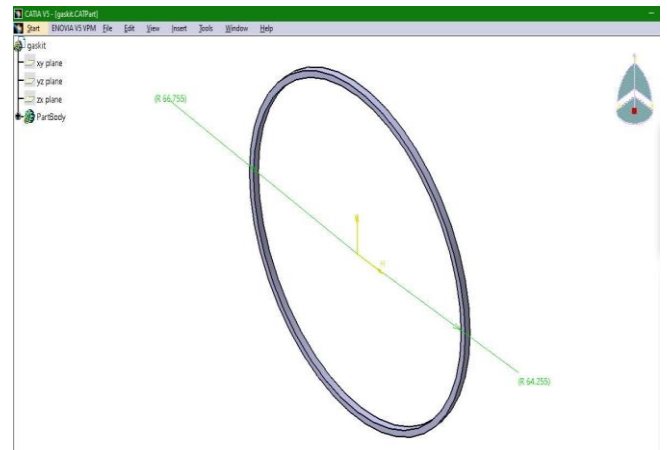

Fig no 11: Gasket

4.1.4 Casing

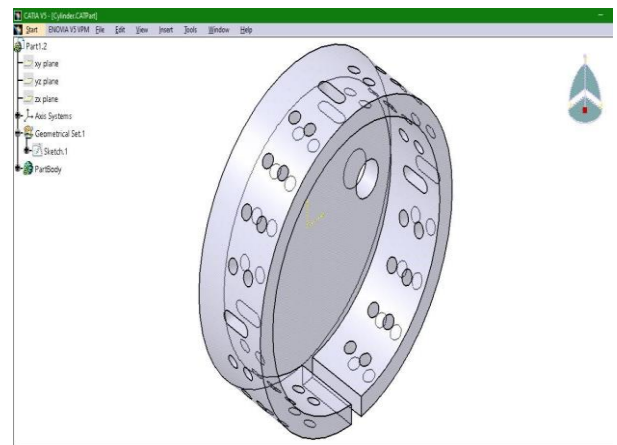

Fig no 12: case 1

4.1.5. Casing 2

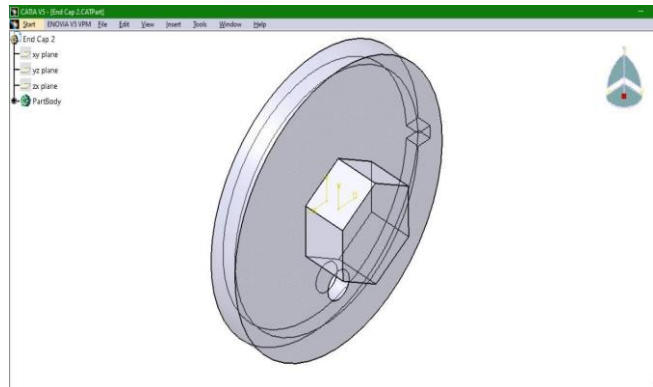

Fig no 13: Case 2

4.2. Design no 2

First design was rejected due to many limitations. First among which was less thermal efficiency. Due to the closed design of the HHO cell heat dissipation was difficult. In our analysis we found out that increased working high temperature of HHO cell eventually reduce the overall efficiency of the cell. Another problem with which we came along in the first design was about fitting the outer casing of the cell which would eventually hold the whole cell together. It was a container like design in which the whole setup was to be placed. The first design was fully dependent on the outer acrylic casing for support. So it was necessary to modify the design in which more heat dissipation is possible and proper support from different parts is given.

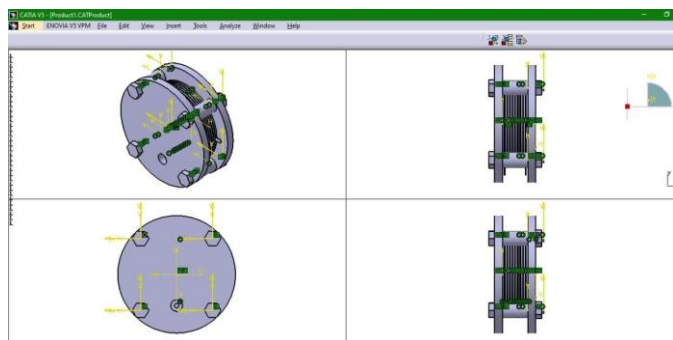

Fig no 14: design 2

4.2.1. Neutral plate

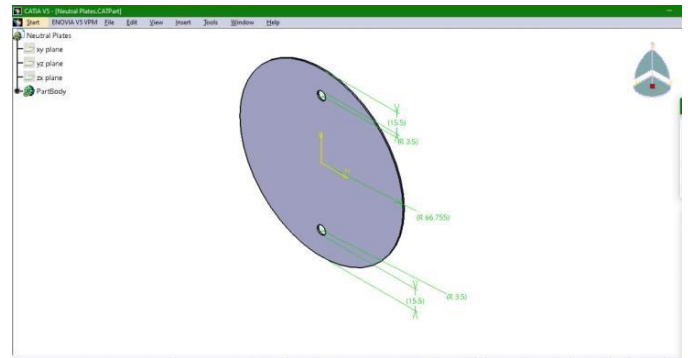

Fig no 15: Neutral plate

4.2.2. Anode and cathode plates

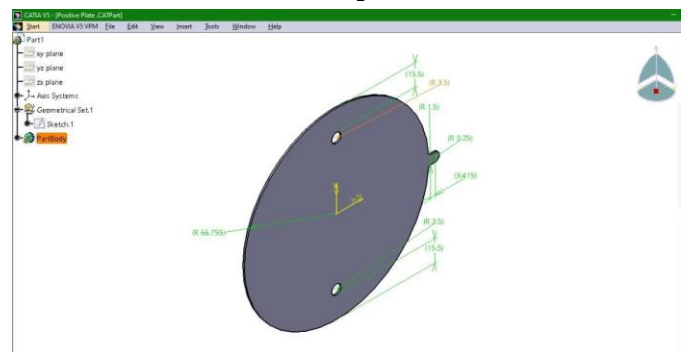

Fig no 16: Anode and cathode plate

4.2.3. Cylinder

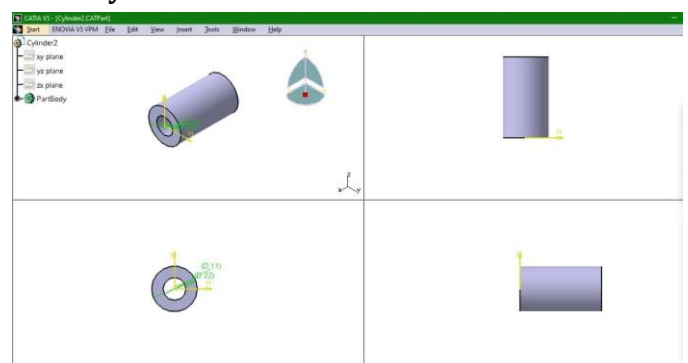

Fig no 17: Cylinder

4.2.4. Nut

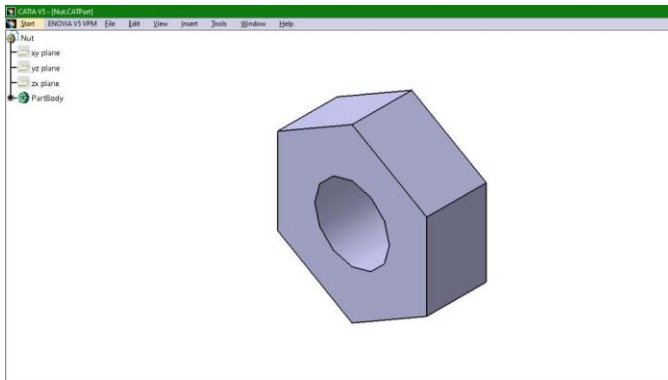

Fig no 18: Nut

4.2.5. Bolt

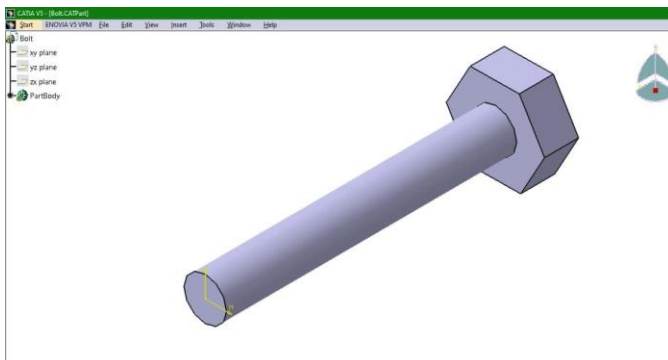

Fig no 19: Bolt

4.2.6. Gasket

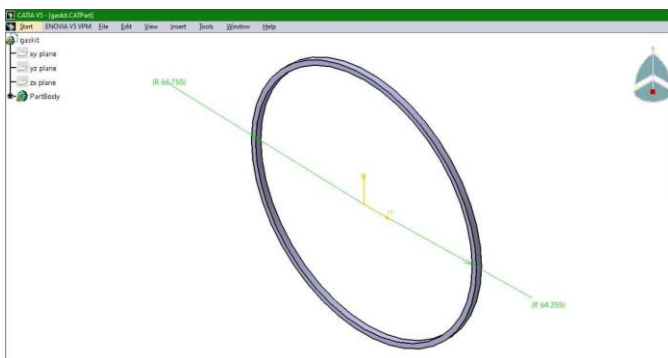

Fig no 20: Gasket

4.2.7. Side plate

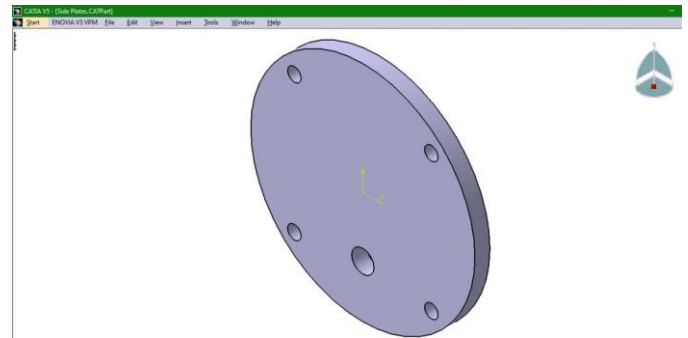

Fig no 21: Side plate

CONCLUSIONS

Thus I conclude, that the problems faced due to increasing Global warming that is caused due to excess use of fossil fuels can be decreased to a certain extent by replacing the fossil fuels with the Oxy Hydrogen in IC engine which will reduce emissions and we can have some time for complete transition to electric vehicles. The report provides an analysis and evaluation of a HHO dry cell. The report also investigates the fact that the analysis conducted has limitation

REFERENCES

- 1) Ammar A. Al-Rousa ,Saed A. Musmar , Effect of anodes-cathodes interdistances of HHO fuel cell on gasoline engine performance operating by a blend of HHO, International journal of hydrogen energy.(2018).
- 2) Ammar A. Al-Rousan ,Reduction of fuel consumption in gasoline engines by introducing HHO gas into intake manifold, International journal of hydrogen energy 35 (2010) 12930-12935.
- 3) Balaji Subramanian, Saleel Ismail ,Production and use of HHO gas in IC engines, International journal of hydrogen energy (2018)
- 4) Hong-bo Liu , Haotian Xu , Liang-ming Pan, Ding-han Zhong , Yang Liu, Porous electrode improving energy efficiency under electrode-normal magnetic field in water electrolysis, International journal of hydrogen energy.
- 5) Mohamed M. EL-Kassaby, Yehia A. Eldrainy , Mohamed E. Khidr, Kareem I. Khidr, Effect of hydroxy (HHO) gas addition on gasoline engine performance and emissions, Alexandria Engineering Journal
- 6) Noor Alam, K.M. Pandey, experimental study of gas (HHO) production with variation in current, voltage and electrolyte concentration, material science and engineering 225(2017).

- 7) P. V. Manua , Anoop Sunilb, S. Jayarajc, Experimental Investigation using an On- Board Dry Cell Electrolyzer in a CI Engine working on Dual Fuel Mode, Energy Procedia 90 (2016) 209 – 216.
- 8) Pierpaolo Polverino , Federica D’Aniello, Ivan Arsie, Cesare Pianese , Study of the energetic needs for the on-board production of Oxy-Hydrogen as fuel additive in internal combustion engines, Energy Conversion and Management 179 (2019) 114–131.
- 9) Tamer M. Ismaila, Khaled Ramzya, Basem E. Elnaghib, T. Mansoura, M.N. Abelwhabb, M. Abd El-Salamc, M.I. Ismaild, Modelling and simulation of electrochemical analysis of hybrid sparkignition engine using hydroxy (HHO) dry cellEnergy Conversion and Management 181 (2019) 1–14.
- 10) Tamer M. Ismaila, Khaled Ramzya,, M.N. Abelwhabb, Basem E. Elnaghib, M. Abd El-Salamc, M.I. Ismaild, Performance of hybrid compression ignition engine using hydroxyl (HHO) from dry cell, Energy Conversion and Management 155 (2018) 287–300.
- 11) Tamer Nabil, Mohamed M. Khairat Dawood Enabling efficient use of oxy-hydrogen gas (HHO) in selected engineering applications; transportation and sustainable power generation Journal of Cleaner Production 237 (2019) 117798.
- 12) Yang Liu, Liang-ming Pan, Hongbo Liu, Tianming Chen, Siyou Yin, Mengmeng Liu Effects of magnetic field on water electrolysis using foam electrodes, International journal of hydrogen energy.