

Design and Analysis of a Monolithic Dome Using STAAD.Pro V8i

Rashmi C. Khanorkar¹, Prathamesh S. Narkar², Ketan S. Kumbhar³, Parth H. Bodalia⁴, Manoj U. Deosarkar⁵

^{1,2,3,4}UG Students, Dept. of Civil Engineering, Dr. D. Y. Patil of Engineering and Technology, Lohegaon Dist. Pune, Maharashtra, India.

⁵Assistant Professor at Dept. of Civil Engineering, Dr. D. Y. Patil of Engineering and Technology, Lohegaon Dist. Pune, Maharashtra, India.

Abstract - This project includes design and analysis of monolithic dome having a substructure of auditorium. They are designed for uniform loading over the plates. In this study by applying point loads over the nodal joints analysis and design of concrete dome structure will be done using STAAD.Pro. This project is a virtual project meaning that no actual or practical tests are supposed to be done for completion of this project. The project is initiated with the collection of information from existing journals, papers called literature review. After collecting the relevant information the project is started. Dead load and live load are assigned as the plate load. The safe loads are found from the design results against various loading cases. Axial forces, bending moment, nodal joint load are to be designed by using STAAD.Pro.

Keywords—Dome, STAAD.Pro, Nodal Joint Load, Shear Force and Bending Moment

1. INTRODUCTION

A monolithic dome (from Greek mono- and -lithic, meaning "one stone") is a structure cast in a one-piece form. The form may be permanent or temporary and may or may not remain part of the finished structure. It is the form of monolithic architecture. Domes are ambient structure developed from A.D periods which are constructed for getting large volume from the structure. Domes can be design to fit any architectural homes, cabins, churches, school, gymnasiums, arenas, stadium bulk, auditorium, landlord dwelling and other various privately and publicly owned facilities. They are cost-efficient, earth-friendly, extremely durable and easily maintained. Most importantly, a Monolithic Dome uses about 50% less energy for heating and cooling than a same-size, conventionally constructed building.

Beginning in 1970, Monolithic Domes have been built and are in use in virtually every American state and in Canada, Mexico, South America, Europe, Asia, Africa and Australia. Monolithic Domes are neither restricted by climate

nor by site location. In terms of energy consumption, durability, disaster resistance and maintenance, Monolithic Domes perform well in any climate, even extremely hot or cold ones. And they can be constructed on virtually any site: in the mountains, on beaches, even underground or underwater. The problem of cost effective materials is addressed by using cement stabilized earth blocks (CEB's) or RCC construction in the construction of the dome. This project seeks to investigate the dome structure as a low cost housing alternative the dome when finished is earthquake, tornado and hurricane resistant.

1.1 Objective

The objectives of this research can be summarized briefly as follows:

1. The main objective of this project is to study analysis and design of Monolithic Concrete Dome using STAAD.Pro with substructure of an auditorium.
2. To study the design of structural elements of a dome structure such as shell structure, ring beam, column and footing.
3. To analyze the structure for carrying the various load like dead load live load wind load and seismic load.
4. To design the structure according to Indian standards codal provisions.

Following IS code will be used for designing RCC structure.

- IS 456-200
- IS 1893-2002/2005
- IS 875-1987

2. LITERATURE REVIEW

The basic objective of this chapter is to get inside into the previous findings so that it will help to know the gap in earlier studies and to justify the research problem selected by me for the study purpose. The extensive literature review was carried out by referring standard journals, reference books, I.S. Code and conference

proceeding. The major work carried out by different researchers is summarized below:

2.1 Analysis and design of spherical dome structure by using STAAD.Pro – R.Madhukumar, U. Manivasan, V.S.Satheesh And S. Suresh Babu – International Journal of Modern trends in engineering and research ISSN: 2455-0876

In this investigation by applying point loads over the nodal joints analysis and design of concrete dome structure was done using STAAD.Pro. An 8.49m rise with 30m diameter dome and a support height of 14m was considered for the design. Dead load is assigned as plate load and the live load is assigned as point load over the nodal joints. The safe loads were found from the design results against various loading cases.

Findings- Dome, STAAD.pro, Nodal Joint Load, Shear Force and Bending Moment.

2.2 Design and analysis of geodesic tunnel dome for an auditorium – Arya Abhishek, Phadtare Shubham, Patil Pratik, Tipare Harshal, Reetika Sharan- International Research Journal of Engineering and Technology (IRJET)

The study shows the result of static analysis and design of geodesic tunnel dome. The authors collected the dimension of an auditorium, the length is 40m & width of the inner side is 20m with the height of the crown is 10.63m. They built the model required for the project. They also calculated the forces acting (i.e. Wind load, Dead load, Live Load &, etc.) on each panel of the structures for designing purpose, this load is resisted by two hinged arches which are further transferred to the RCC column to soil strata through the foundation. Wind intensity as per (IS 875-1987 part-3) is 44 m/s.

2.3 Acoustic of monolithic dome structures – Mostafa Refat Ismail, Hazem Eldalyn (2017), Frontiers of Architectural Research (2018)

The author researched on the Acoustic of monolithic dome structures. Which describes the Analyse monolithic structures including being cost-efficient, earth-friendly, extremely durable, and easily maintained. Regarding climate, the monolithic domes are easily constructed and are cost effective on constructing. The main aim of the paper by the author is to examine the various acoustic treatment sand parametric configurations of monolithic dome sizes. Destructions of these structures provides the highest survivability rates. These dome structures are utilized for domestic use because the scale allows the focal points to be positioned across daily life activities. Monolithic structures

cast from one piece to form a homogeneous structure. Acoustical Analyse cannot be easily standardized because of variation in the size, shape, and volume of concave domes. Author studied that Monolithic dome structures are constructed for residential spaces. Further is the figure showing a typical residential unit constructed out of monolithic domes.

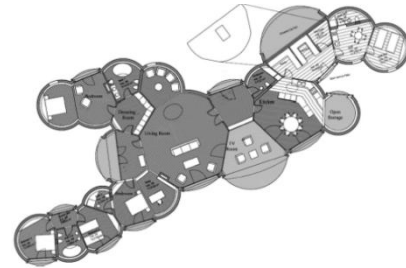
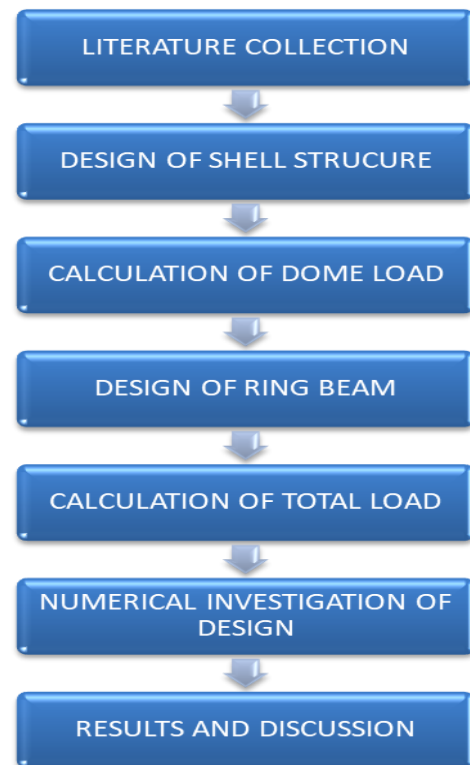

Fig.2.3 A typical residential unit constructed out of monolithic domes

Findings: Behavior of monolithic structure, Configuration of monolithic dome sizes, survivability rates.

3. METHODOLOGY

The project study described two stages. The primary data was taken from a Literature survey targeted by web searches and review of e-books, manuals, codes and -journal papers. After review the problem statement is defined and the selected dome models are taken up for detail study and analysis purposes. This project execution follows the flow chart given below:



3.1 GEOMETRY

Table 3.1 Geometry of Dome

Sr. No.	Description	Circular Dome
1.	Diameter of Column	600mm
2.	Height of Wall (M)	3.5m
3.	Hopper Height (M)	7.07m
4.	Height of Staging	3.5m
5.	Bracings	220x600mm
6.	Thickness Of Roof Slab	250mm
7.	Thickness of Wall	300mm
8.	Size of Bottom Beam	220x600mm
9.	Staging Level	2
10.	Type of Soil	Medium Soil
11.	No. of Column	12
12.	Top of Diameter Dome	0
13.	Bottom of Diameter Dome	10m
13.	Type of Bracing	Normal
14.	Unit Weight	Concrete = 25KN/m ³
15.	Material	M25 Grade Concrete & Fe415

3.2 Material Properties and Loads

This work has been analyzed using STAAD.Pro software. Dead load in terms of self-weight is considered for the analysis. Pressure of plates is taken as 6 KN/m. Live load of 7 kN/m² is provided in accordance to IS 875 (Part2). Below table shows the gravity loads. For seismic weight, total dead load and 50 percent of live load is considered as per Table 8 of IS 1893 (Part1): 2002.

Table 3.2 Gravity loads which are assigned to the RC buildings as per IS: 875 (Part 2)

Gravity Load)	Value
Slab load (dead load)	3 (kN/m ²)
Live load	3.5 (kN/m ²

3.3 Earthquake and Wind Load Data

The structures are more vulnerable to lateral loads, as the height of building increases the structures becomes flexible and prone to damage. Hence lateral loads are mainly derived from seismic and wind loads for which structure needs to be analyzed:

Table 3.3: Earthquake and Wind Load Considerations (IS 1893 (part-1):2016)

Seismic Zone	III
Zone Factor Z	0.16
Importance Factor I	1
Response Reduction Factor	3
Damping Ratio	0.05
Type of Soil	Medium
Basic Wind Speed (Vb)	39 m/sec
Design Wind Pressure Pz	0.960 Kn/m

3.4 Load Combinations

The structure is analyzed considering proper ratios of the applied dead loads, live loads and seismic loads. The Load combinations are given in IS 1893 (part-1):2016 which has been presented in Table 3.4. As the seismic loads are assigned in both X-Horizontal and Y-Vertical direction so E.LX and E.LY should be considered.

Table 3.4: Load combinations

SR NO	LOAD COMBINATION	FACTORS
1	Dead load	1.5
	Live load	1.5
2	Dead load	1.2
	Live load	1.2
	Wind load (X direction)	1.2
3	Dead load	1.2
	Live load	1.2
	Wind load (Y direction)	1.2
4	Dead load	1.2
	Live load	1.2
	seismic load(X direction)	1.2
5	Dead load	1.2
	Live load	1.2
	Seismic load (Y direction)	1.2
6	Dead load	0.9
	Live load	0.9
	Wind load (X direction)	0.9
7	Dead load	0.9
	Live load	0.9
	Wind load (Y direction)	0.9
8	Dead load	0.9
	Live load	0.9
	Seismic load (X direction)	0.9
9	Dead load	0.9
	Live load	0.9
	Seismic load (Y direction)	0.9

4. DESIGN RESULTS -

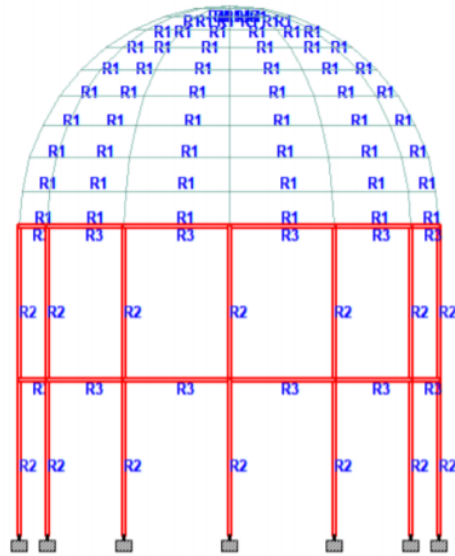
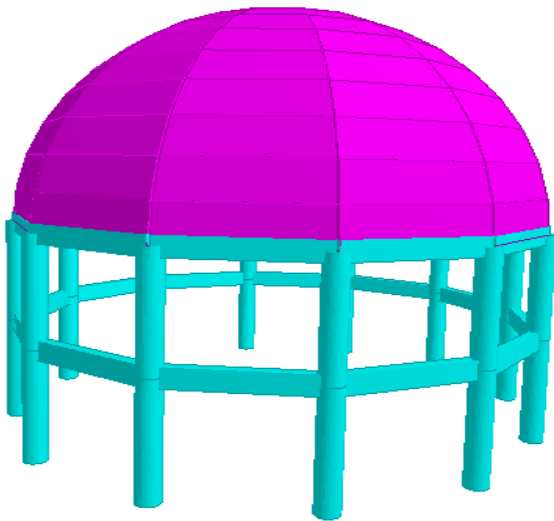

Fig.4.3 Showing details of monolithic dome

4.1 3D view of dome structure

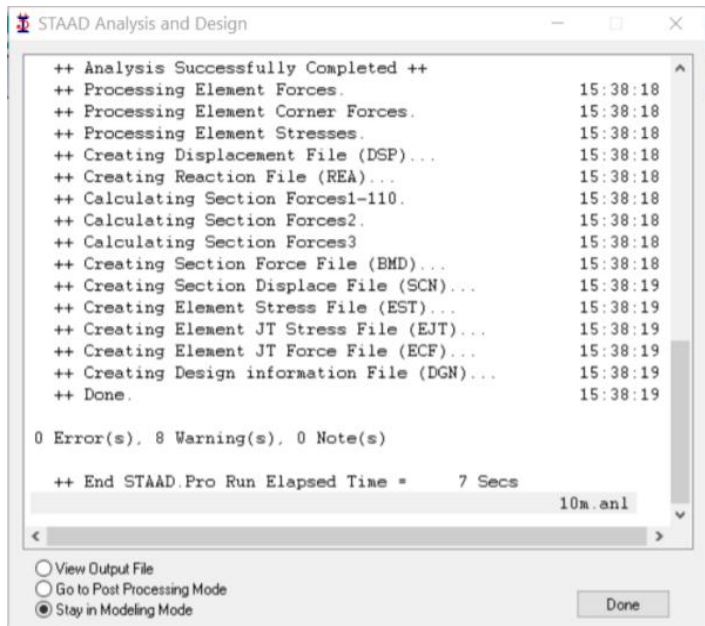

Fig.4.2 Complete Analysis Result

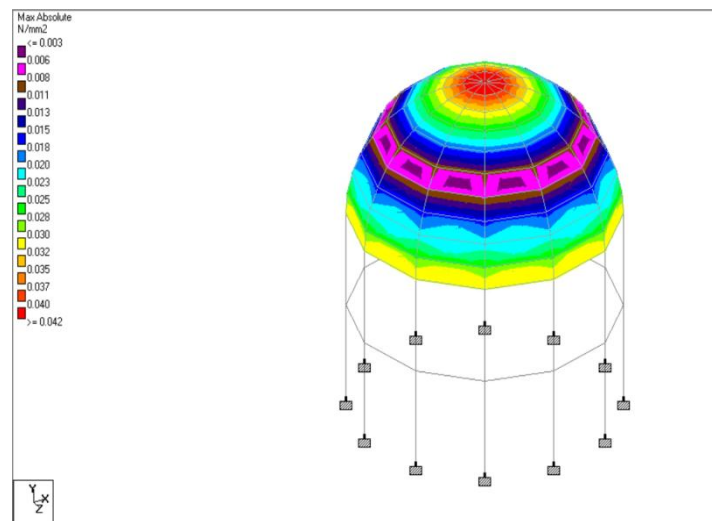

Fig.4.4 Max absolute plate stresses.

Plate stresses are shown in figure 4.4. were red colour showing maximum stress. Yellow colour is showing moderate stresses and green colour showing less stresses in structure

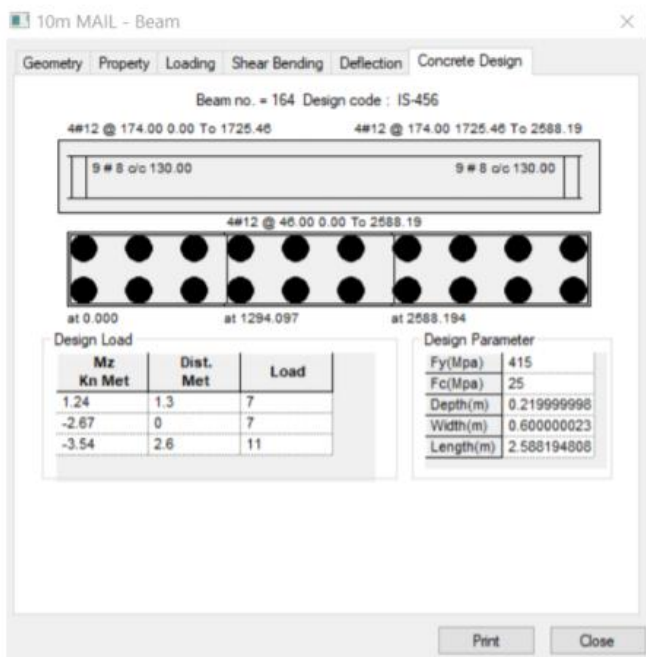

Fig.4.5 Reinforcement in concrete rectangular beam

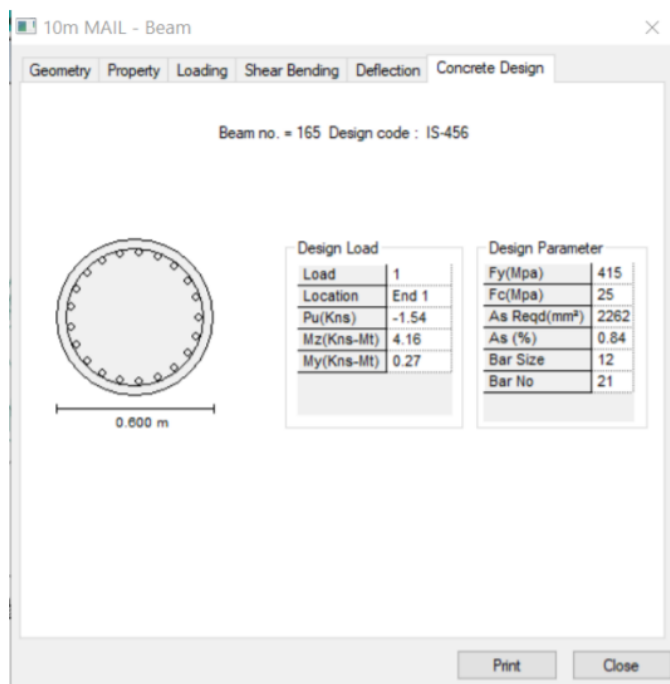

Fig.4.6 Reinforcement in concrete circular beam

Design of monolithic dome was done by IS-456. Rectangular beams and circular column are used in monolithic dome. Reinforcement were calculated in STADD.Pro shown in fig. 4.5 & 4.6.

5. CONCLUSIONS

From this study we deal with brief information of dome, some recent innovation and focus using it in modern housing. Structural behavior is studied of RC dome using STAAD.Pro v8i. The assumed dimensions of beam is 220mm x 600mm, column of diameter 600mm & plate thickness is 250mm are safe for carrying various load. For the applied load cases and combination structure comes under safe zone.

REFERENCES

1. Design and analysis of geodesic tunnel dome for an auditorium – Arya Abhishek, Phadtare Shubham, Patil Pratik, Tipare Harshal, Reetika Sharan- International Research Journal of Engineering and Technology (IRJET).
2. Mostafa Refat Ismail, Hazem Eldalyn - Acoustic of monolithic dome structures - Received 27 May 2017; received in revised form 1 November 2017; accepted 9 November 2017.
3. Rahul Ingale Amol Dighe Vaibhav Badhe Girjinath Damale Prof. Pote R.K. - Design and Analysis of Monolithic Dome Structure - Vol. 6, Issue 04, 2018 - ISSN (online): 2321-0613.
4. Analysis and design of spherical dome structure by using STAAD.Pro – R.Madhukumar, U. Manivasan, V.S.Satheesh And S. Suresh Babu – International Journal of Modern trends in engineering and research ISSN: 2455-0876
5. Kiran P. Khandare , Dr. Sachin B. Mulya - Analysis and Design of Dome Structure - Volume 5, Issue 06, June-2019.