

# SMART CONTROL OF PV SOLAR FARM AS STATCOM (PV-STATCOM) FOR ENHANCING GRID POWER

**Dilavar Basha K<sup>1</sup>**

*Department of EEE*

*RMKCET*

*Chennai, Tamilnadu*

**Lakshmi Priya V<sup>2</sup>**

*Department of EEE*

*RMKCET*

*Chennai, Tamilnadu*

**Divya N<sup>3</sup>**

*Department of EEE*

*RMKCET*

*Chennai, Tamilnadu*

**Manjula S<sup>4</sup>**

*Department of EEE*

*RMKCET, Chennai, Tamilnadu*

\*\*\*

**Abstract**—This paper presents a novel control of PV solar system as a FACTS device STATCOM, termed PVSTATCOM, for power oscillation damping (POD) in transmission systems. In the proposed control, A solar panel is connected to high gain converter and to the inverter of STATCOM is employed to have higher voltage gain in the midpoint of the transmission line enabling to achieve reasonable power gain in the system. Reactive power compensation plays a vital role to enhance the power transfer capabilities in long transmission line. Here we use the STATCOM with dc chopper to control the power flow and also to improve the reactive power compensation in long transmission line. PV panel acts as generating system when grid normal operation. PV compensates when availability of solar power. When PV power is zero the system acts as STATCOM. Simulation were carried out using MATLAB Simulink. The results were obtained with & without compensation. Here the frequency of the injecting power should be matched with the grid frequency  $\omega$ . These results show that the supply of reactive power from source are reduced when STATCOM in circuit & thereby increase the transfer capacity of line.

**Keywords**---*Photovoltaic solar power systems, voltage control, reactive power control, power oscillation damping, FACTS, STATCOM, power transmission, PV ramp rate*

## 1. INTRODUCTION

LOW frequency electromechanical power oscillations (typically 0.1 - 2 Hz) are recognized as one of the major limiting factors in power transfer over long transmission lines [1]. Conventionally, these oscillations are damped by Power System Stabilizers (PSS) integrated with synchronous generators [1]. However, Flexible AC Transmission System (FACTS) devices have been effectively utilized in power systems for damping these power oscillations and thereby enhancing the power transfer capability in transmission lines [2-4]. Performances of various FACTS devices equipped with

power oscillation damping (POD) controllers are described in literature, such as, Static Var Compensators(SVC) [5], Static Synchronous Compensators (STATCOM) [6, 7], Thyristor Controlled Series Compensators (TCSC) [8], and Convertible Static Compensator (CSC) [9]. Large scale PV solar farms in excess of 100 MW are being increasingly connected worldwide. These include Kamuthi (648 MW), in Tamil Nadu, India [10], Rancho Cielo Solar Farm (600 MW), Solar Star I and II (579 MW), Topaz Solar Farm (550 MW), Agua Caliente Solar Project (295 MW) California Valley Solar Ranch Farm (250 MW) in USA, and Huanghe Hydropower Golmud Solar Park in China (200 MW) [11-13].

The potential of reduction in power system stability with significant amount of inertia-less power injection from PV solar plants in the grid is described in [14-16]. Smart PV inverter controls such as Constant (off-unity) Power Factor, Volt/Var, Volt/Watt, Frequency Watt, Low/High Voltage Ride Through, Low/High Frequency Ride Through, etc., have been proposed [17] and also demonstrated on a large scale PV solar farm [18]. A novel control of PV solar farm as STATCOM (PV-STATCOM) was presented for enhancing the connectivity of wind farms in the night [19] and for increasing power transfer capacity through damping of power oscillations both during night and day [20]. This control technique utilized the entire inverter capacity in the nighttime and the inverter capacity remaining after real power generation during daytime for power oscillation damping. An eighth-order POD controller for large PV solar farm was proposed in [21], whereas an energy function based design of POD controller was presented in [22]. Both these controllers are relatively complex in design. All the POD controls in the above papers [19-22] are based on remaining inverter capacity during daytime. Hence, the proposed POD capability of solar farm is limited during day, indeed becoming zero during hours of full sun. This paper proposes a novel PV-STATCOM control for POD, based

on a patent pending technology [23]. In this proposed control, if any disturbance occurs in the power system causing undesirable power oscillations, the PV solar farm autonomously disables its real power generating function for a short period (typically less than a minute), and makes its entire inverter capacity available for operating as STATCOM to damp power oscillations through reactive power modulation. As soon as the power oscillations are reduced to an acceptable level, the solar farm restores its power output to its pre-disturbance level in a ramped manner. Another novel contribution of this paper is that the POD function is kept activated during the ramp up of power to its pre-disturbance value utilizing the inverter capacity remaining after real power generation. This prevents any recurrence of power oscillations and also allows a much faster ramp-up than prescribed by grid codes [24] where such a damping function during ramp-up is not envisaged. PV Solar System Control as STATCOM (PV-STATCOM) for Power Oscillation Damping Rajiv K. Varma, Senior Member, IEEE and Hesamaldin Maleki, Student Member, IEEE L.

## 2. PROPOSED SYSTEM

In this proposed method the PV system is used as the generating system. When in need of the compensation system PV source is used for compensation and when the unavailability of the PV source the system acts as a normal STATCOM. The STATCOM operates according to voltage source principles, combining unique PWM (Pulsed Width Modulation) switching in MOSFET. The device's effective rating and response speed are unequalled, and can be dedicated to active harmonic filtering and voltage flicker mitigation.

A solar panel is connected to high gain converter and to the inverter of STATCOM is employed to have higher voltage gain in the midpoint of the transmission line enabling to achieve reasonable power gain in the system.

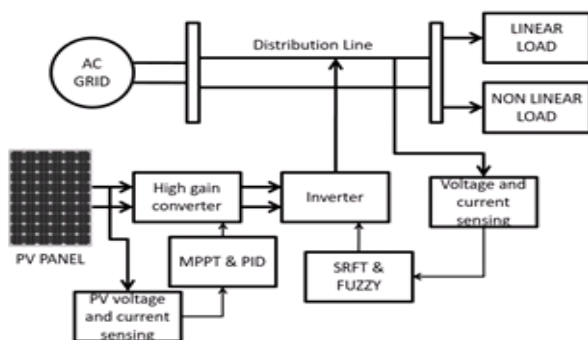

Fig .1. BLOCK DIAGRAM

In grid connected applications the synchronization of output signals of the converters to be connected with grid parameters- frequency and phase is of great importance. Different methods based on Fourier transforms, zero crossing detection, Kalman filters, phase-locked loops (PLL) and others are used for this synchronization PLL- **phase locked loop** or **phase lock loop (PLL)** is a control system that generates an output signal whose phase is related to the phase of an input signal.

There are several different types; the simplest is an electronic circuit consisting of a variable frequency oscillator and a phase detector in a feedback loop. The oscillator generates a periodic signal, and the phase detector compares the phase of that signal with the phase of the input periodic signal, adjusting the oscillator to keep the phases matched.

To reduce the harmonic content with normal inverter we are using FIVE LEVEL INVERTER. Five level inverters can draw input current with low distortion. The Five level inverter can operate at both fundamental switching frequencies that are higher switching frequency and lower switching frequency. It should be noted that the lower switching frequency means lower switching loss and higher efficiency is achieved.

## Comparison

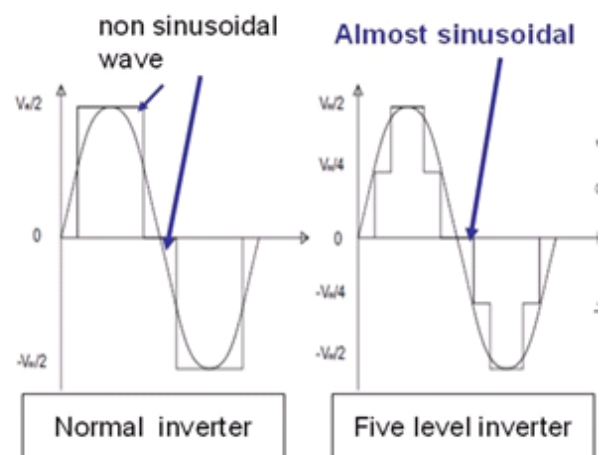

### 3. SIMULATION DIAGRAM

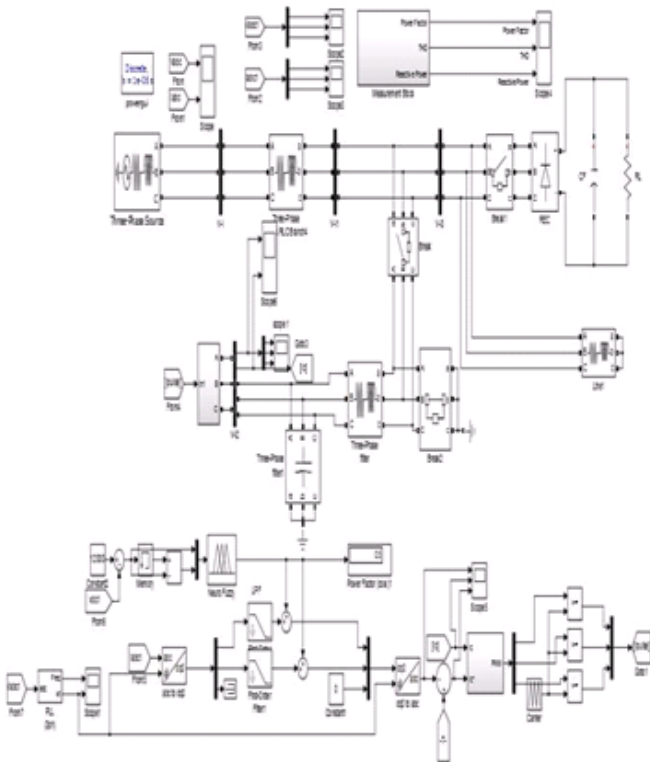

Initially we are connecting PV to the source with certain voltage. After certain point we are disconnecting the PV using step input. Since, the Grid is connected with the Linear load initially no power factor issues and harmonic distortion occurs. After 0.5 seconds the non-linear load is also connected to the Grid. Due to this total harmonic distortion and power factor increases. To compensate this issues PV is used. In the absence of PV, the system will act as normal STATCOM for compensation.

#### a. SIMULATION RESULTS

The proposed inverter is analyzed for the performance assessment using the simulation circuit a shown in figure 3 above. MATLAB Simulink is used for simulation study due to its versatility and accuracy compared to other software.

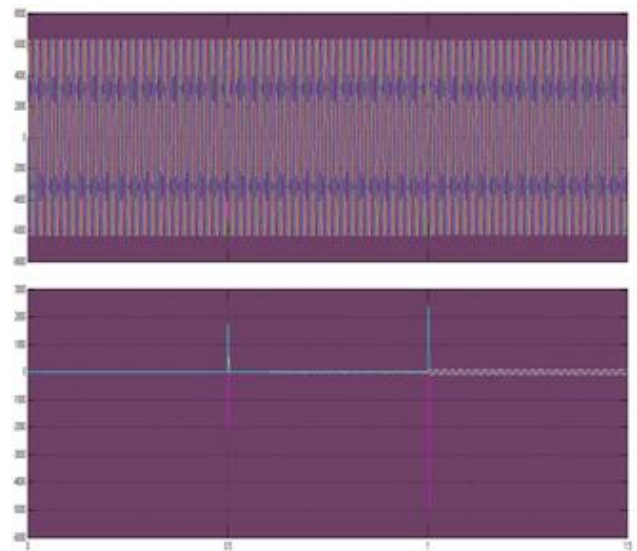

Figure 4 – GRID VOLTAGE AND CURRENT

The above figure shows that the grid side voltage and current is maintained same. Before, 0.5sec only linear load is present and there is no any voltage drop. After 0.5sec non-linear load is also added and voltage drop occurs. To avoid this, STATCOM is used. In both the cases PV source is present. After t=1sec, step input given to PV source is reduced to 0. But the grid side voltage and current does not show much variation.

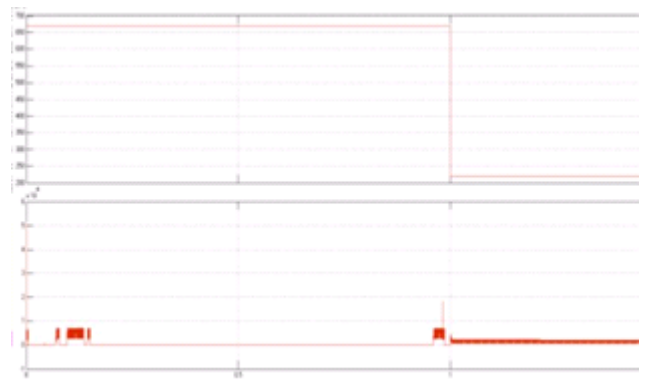

Fig 4.1 - SOLAR VOLTAGE AND CURRENT

The above figure shows that the solar side voltage and current is maintained same. Initially, the step input given to PV is 12V. After t=1 s, the step input is reduced to 0V. The drop in voltage is shown. Similarly current also changes.

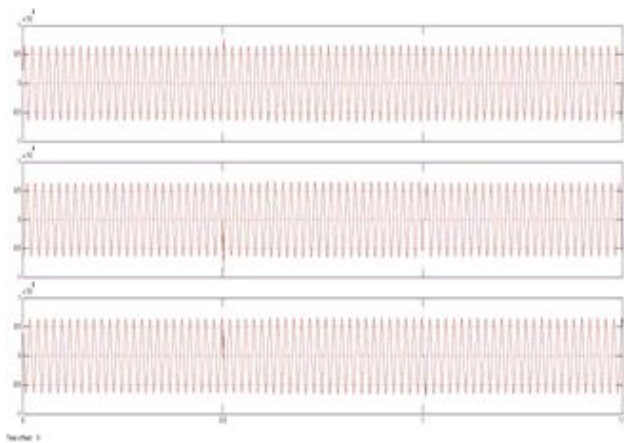

Fig.4.2- LINE VOLTAGE

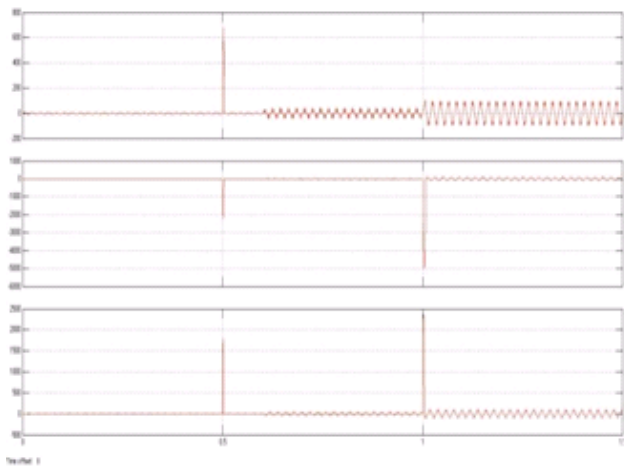

Fig.4.3- LINE CURRENT

The above figure4.3 shows that the grid side voltage and current is maintained same. Before, 0.5sec only linear load is present and there is no any voltage drop. After 0.5sec non-linear load is also added and voltage drop occurs. To avoid this, STATCOM is used. In both the cases PV source is present. After  $t=1$ sec, step input given to PV source is reduced to 0. But the grid side voltage and current does not show much variation.

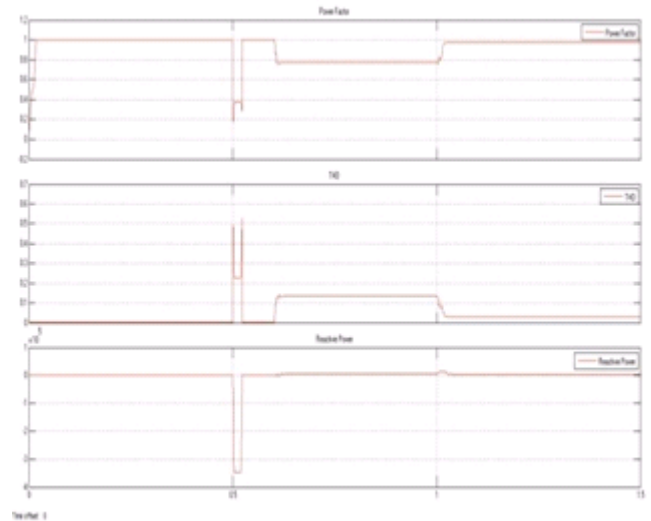

Fig.4.4-POWER FACTOR, THD, REACTIVE POWER

Power factor is maintained at unity when linear load alone acts. In the presence of non-linear load power factor changes slightly. When PV source is not present, power factor is again maintained at unity.

Similarly, harmonics issues is resolved in the presence of non- linear load and removal of PV.

Reactive power is maintained constant in all the cases. After  $t=0.5$ secs the waveform undergoes tuning, for better accuracy.

### b. CONCLUSION

A new five level inverter is proposed and simulated using MATLAB Simulink to compensate the power factor issues and total harmonic distortions when non-linear load is connected. The multilevel inverter can operate at both fundamental switching frequencies that are higher switching frequency and lower switching frequency. It should be noted that the lower switching frequency means lower switching loss and higher efficiency is achieved. The simulation results confirm the efficacy of the proposed system.

### REFERENCES

- [1] P. Kundur, N. J. Balu, and M. G. Lauby, Power system stability and control vol. 7: McGraw-hill New York, 1994.
- [2]. N. G. Hingorani and L. Gyugyi, Understanding FACTS: concepts and technology of flexible AC transmission systems: Wiley-IEEE press, 2000.



[3] R. M. Mathur and R. K. Varma, Thyristor-based FACTS controllers for electrical transmission systems: John Wiley & Sons, 2002.

[4].Y. Xiao, Y. Song, C.-C. Liu, and Y. Sun, "Available transfer capability enhancement using FACTS devices," IEEE Trans. Power systems, vol. 18, pp. 305-312, 2003.

[5]X. Y. Bian, Y. Geng, K. L. Lo, Y. Fu, and Q. B. Zhou, "Coordination of PSSs and SVC Damping Controller Improve Probabilistic Small-Signal Stability of Power System with Wind Farm Integration," IEEE Trans. Power Systems, vol. 31, pp. 2371-2382, 2016.

[6].M. Haque, "Improvement of first swing stability limit by utilizing full benefit of shunt FACTS devices," IEEE Tran Power Systems, pp. 1894- 1902, 2004.

[7]. N. Mithulananthan, C. A. Canizares, J. Reeve, and G. J. Rogers, "Comparison of PSS, SVC, and STATCOM controllers for damping power system oscillations," IEEE Trans. Power Systems, pp. 786-792, 2003.

[8] A. M. Simões, D. C. Savelli, P. C. Pellanda, N. Martins, and P. Apkarian, "Robust design of a TCSC oscillation damping controller in a weak 500- kV interconnection considering multiple power flow scenarios and external disturbances," IEEE Trans. power systems, vol. 24, pp. 226236, 2009.

[9].S. Arabi, H. Hamadanizadeh, and B. B. Fardanesh, "Convertible static compensator performance studies on the NY state transmission system," IEEE Trans. Power Systems, vol. 17, pp. 701-706, 2002.

[10].S. Eftekharnajad, V. Vittal, G. T. Heydt, B. Keel, and J. Loehr, "Small Signal Stability Assessment of Power Systems With Increased Penetration of Photovoltaic Generation: A Case Study," IEEE Trans. Sustainable Energy, vol. 4, pp. 960-967, 2013.

[11]C. Tiba and E. d. A. Ricardo, "Siting PV plant focusing on the effect of local climate variables on electric energy production–Case study for Araripina and Recife," Renewable Energy, vol. 48, pp. 309-317, 2012.

[12]A. Sharma, "A comprehensive study of solar power in India and World," Renewable and Sustainable Energy Reviews, vol. 15, pp. 1767-1776, 2011.

[13] R. Shah, N. Mithulananthan, R. Bansal, and V. Ramachandaramurthy, "A review of key power system stability challenges for large-scale PV integration," Renewable and Sustainable Energy Reviews, vol. 41, pp. 1423-1436, 2015.