

# IOT BASED NOISE AND AIR QUALITY MONITORING SYSTEM

Rajesh Bhambare<sup>1</sup>, Swati Khairnar<sup>2</sup>

<sup>1</sup>Associate Professor, Department of Electronics Engineering, Pravara Rural engineering College, Loni, India

<sup>2</sup>Student, Department of Electronics Engineering, Pravara Rural engineering College, Loni, India

\*\*\*

**Abstract** - Rapid growth in infrastructure and industrial plants causes environmental problems such as pollution (Air & Noise), climate change, malfunctioning, and has a significant effect on the need for an operationally adaptable, effective, cheap, and intelligent monitoring system. In this context, where there is a mix of several computer science problems, wireless communication, and electronics; Smart Sensor Networks is an evolving research area. Within this project, a solution is proposed to track air and noise emission levels within industrial environments or to use a wireless embedded computing device to create a limited area of interest. Innovation, such as the Internet of Things (IoT), is being used as a solution resulting from a converged computer science and electronics field. In this case, the sensing devices are connected to the embedded computing system for monitoring the fluctuation of parameters such as noise and air pollution levels from their normal levels. This model is adaptable and distributive to any infrastructural setting for the necessity of continuous monitoring, regulating, and conduct analysis. The functional presentation of the prototype model is assessed using a prototype implementation, which consists of Arduino UNO board, sensor modules, Thinkspeak, and MATLAB. For two or three parameters such as noise, CO, and smoke levels, deployment is assessed for normal standards of activity or criteria that include monitoring of pollution control to make the atmosphere smart and environmentally sustainable. Air Quality Planning and Standards' core mission is to preserve air quality. The concentration of air pollution can be calculated by observing the pollutants present in that area's air, such as humidity level, temperature level, dust level, CO level, smoke level, etc. Here we recommend a monitoring system for air quality pollution, which allows us to monitor and check the quality of live air in specific areas through IoT. With the rapidly increasing technology, it would be nice to get to know our current climate conditions in this extensively interconnected world of the internet when you can easily reach your own fingertips to the rarest and farthest details. This concept is based on IoT (Internet of Things), an evolving area in which all the devices are connected to a self-made (private web) web. The channel is used for displaying a specific user's weather parameters with a unique channel API key.

**Key Words:** Internet of Things, Air pollution, Noise pollution

## 1. INTRODUCTION

Air pollution, as well as sound pollution, is becoming a growing problem around the world. It is important to control pollution in particular regions, as well as in particular

industries, factories, hospitals, etc. Using our IoT-based air and sound pollution monitoring system, it is easy to monitor pollution levels, such as the level of air pollution in parts per minute and the level of sound pollution in decibels. Here in this system, we have used mainly the Arduino Uno model. The C language used to program the Arduino Uno. Arduino Uno is used in order to convert the analog I/P signal from sensors into the digital signal. The data is sent to a particular authority by means of the Cloud. ESP8266 is used for the Wi-Fi module. It is used to provide services over a public network and on a private network such as LAN, MAN, WAN, etc. Here we use a website to indicate the pollution level from a particular Area over the computer.

In this project, we will build an IoT-based air pollution monitoring system in which we will monitor the air quality through an internet-based web server and cause an alert when the air quality goes above a certain point, which means that there is a sufficient amount of hazardous gas in the air such as CO<sub>2</sub>, smoke, alcohol, benzene, and NH<sub>3</sub>. It will display on the LCD and as well as on the website the air quality in PPM so that we can track it very conveniently. We used the MQ135 sensor, which is the best option for monitoring air quality as it can detect the most harmful gasses and can accurately quantify their volume. You can track the level of pollution from anywhere in this IoT project, using your computer or smartphone.

## 2. OBJECTIVES

Objectives of this system are as follows:

1. To determine the noise in the hazardous area and huge companies.
2. Also, detect gas leakage and fire in companies with the help of vibrators and LEDs.

## 3. LITERATURE SURVEY

More Amruta et al. (2018), in her paper she concentrated on, today, because of expanded contamination of different kinds, it gets undesirable or dangerous to our lives. It influences, for the most part, on the Respiratory arrangement of every single living thing. So as to screen the contamination of Air and Sound from a specific territory, our project proves to be helpful. It utilizes Raspberry Pi, Gas Sensor, Sound Sensor, Arduino, and it sends over the android. Gas sensors are being used to sense contamination or physical amount, for example, dust particles, pollutant gases, for example, Carbon Monoxide, Methane, Ammonia such dangerous gases. Sound Sensors are utilized so as to

detect Sound level in decibels here we have utilized groove sensor.

Ms. Sarika Deshmukh et al. (2017) In this paper, a successful execution for the Internet of Things is utilized for observing climatic states of conditions like air contamination and sound contamination. This paper presents a reasonable design for an adaptable, adaptable, and cost-effective designs for checking the air and sound nature of a specific site. The depiction of this incorporated system engineering and the associated instruments for dependable and precise estimation of boundaries by sensors and move of data or information is finished with the assistance of the web. This framework can give a component to the tasks of the gadgets to improve in the observing stage. This observed information can be acquired from a remote area without really visiting it because of the entrance of the web. The structure of this checking framework depends on the blend or coordinated effort of emotionally conveyed detecting units and data framework for information organization. The job of IoT is the new idea utilized in air and sound contamination estimation, which permits information access from remote areas.

Palaghat Yaswanth Sai et al. (2017) In this paper, he concentrated on, the air and sound contamination is the developing perilous issue. It is important to screen air quality and monitor it for a superior future and sound living for all. Here we propose an air quality just as sound contamination observing framework that permits us to screen and check live air quality just as sound contamination specifically zones through IoT. The framework utilizes air sensors to detect the nearness of dangerous gases/mixes noticeably all around and continually transmit this information to the microcontroller. Additionally, the framework continues estimating sound level and reports it to the online server over IOT. The sensors cooperate with a microcontroller that forms this information and transmits it over the web. This permits specialists to screen air contamination in various regions and make a move against it. Additionally, specialists can keep a watch on the clamor contamination close to schools, emergency clinics, and no sounding regions, and if a framework distinguishes air quality and sound disturbance issues, it alarms specialists so they can take measures to control the issue.

Arnab Saha Kumar et. Al. (2018) This paper proposes an IOT-based method for monitoring a region's Air Quality Index and Noise Intensity. The suggested methodology consists of four modules, which include the air quality index monitoring module, the sound intensity detection module, the cloud-based monitoring module, and the warning module for anomalies. First of all, the air quality index is calculated, taking into account the prevalence of air contaminants in the five parameters. The amplitude of the sound is then measured using the respective sensor. The cloud-based monitoring software ensures the process of acquiring the data with the aid of the Raspberry Pi Wi-Fi module that fulfills the function of periodically analyzing the

information. Finally, the module Anomaly warns the user in the event of an unacceptable situation.

#### 4. EXISTING MODELS

In this day and age, numerous contamination checking frameworks are planned by considering distinctive ecological boundaries. The existing framework model uses Zigbee based remote sensor systems to screen physical and natural conditions with a huge number of applications in various fields. The sensor hubs legitimately spoken with the moving hubs sent on the object of intrigue, which kept away from the utilization of complex directing calculation; however, neighborhood calculations are negligible. RFID is a method for putting away and recovering information through the electromagnetic transmission to an RF perfect coordinated circuit. It is fundamentally used to track and mark things in general stores and manufactories. There are two fundamental segments of RFID frameworks: labels and per users. A tag has a novel distinguishing proof (ID) number and a memory that is used to store extra information, for example, producer, item type, and ecological factors, for example, temperature, stickiness, and so forth... RFID labels can be characterized into three significant classes by their capacity source: dynamic labels, inactive labels, also, semi inactive (semi-dynamic) labels are installed or connected into objects in a normal RFID application. A server is an event of a PC program that is utilized to acknowledge at that point answer to another program demand, called a customer. To oversee organize assets, Servers are utilized. In the servers, the administrations or data are given through the Web that is associated through LAN and made accessible for clients by means of advanced cells, internet browsers, or other internet browser gadgets to make the framework increasingly clever, versatile and productive.

#### 5. PROPOSED SYSTEM

This project is based on the following requirements:

1. Hardware Requirements
2. Software Requirements

##### 1) Hardware Requirements

Hardware required for this system is as follows:

In this project, we have used an Arduino UNO, which is an electronic opensource platform with support for software as well as hardware. It acts as a microcontroller. MQ135 gas sensor is being used in this project for monitoring air pollution and monitoring air quality index. The sensor has the ability to detect  $NH_3$ ,  $NO_x$ , smoke, and  $CO_2$  levels in the air. A sound sensor is also used in the project for detecting sound levels in decibels. Buzzer and LEDs are used for alarming the user or notifying the output. The ESP8266 Wi-Fi module is used for connecting the microcontroller to the internet so that it could transmit the data to the cloud for monitoring. LCD display of 16\*2 Array is being used for having a visual interface of the device.

2) Software Requirements

Software that is required for this project is as follows:

The Arduino integrated development environment is used for programming the Arduino UNO. The project is totally programmed in Embedded C programming language.

6. FLOWCHART

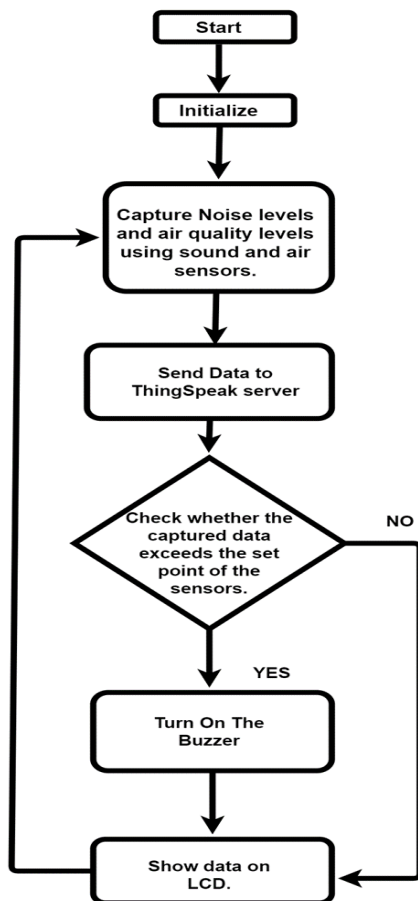

Fig -1: Flowchart of the system

7. ALGORITHM

- a) Author Start
- b) Initialize the system.
- c) Capture Noise levels and air quality levels using sound and air sensors.
- d) Send captured data to ThingSpeak server.
- e) Compare the captured data with the set point of the sensors.
- f) If it exceeds turn on the buzzer and display value on the LCD.
- g) If it does not exceed the data only show the data on the LCD.
- h) Go back to step 3.

8. BLOCK DIAGRAM

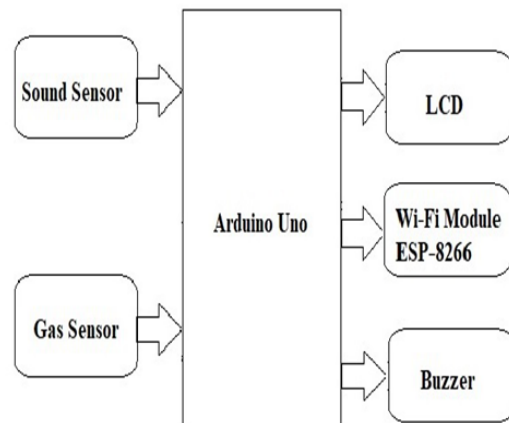

Fig- 2: Block Diagram Of the system.

9. DESCRIPTION OF THE BLOCK DIAGRAM

Initially, the system verifies if all the components that are being connected are in the position to work or not. Then whenever there is a change in the amount of carbon dioxide in the environment or there is any detection of  $NH_3$  in the atmosphere, it is being processed, and relevant data is being sent to the Arduino. Similarly, the sound sensor too detects the noise or sound in the atmosphere in the surroundings in decibels and sends it to Arduino. The data from the sound and gas sensor is being sent to thingspeak server for analysis of the data. The Arduino is connected to the internet via an ESP8266 Module. If the data sent by the sensors is exceeding the normal limits set in the program thingspeak server alerts the Arduino. After which the data is displayed on the LCD display and the Buzzer to alarms the user about the changes.

10. RESULT

IoT based air and sound pollution control system manages and monitors the air pollution and sound pollution around the specified surroundings on a cloud-based internet portal, Thingspeak.com. Also, the thingspeak servers send the data in numerical forms, and that can be visually monitored on the LCD display that is being used. Buzzer alarms the users about the sudden surge or inflation of air pollution or sound pollution in the atmosphere.

Table 1. Results observed by conducting experiment.

Pollutants	Standard value (%)	Observed value (%)
CO	63	44
CO2	60	48
Alcohol	36	34.1
Gas	68	70
Sound	40	36

Table- 1: Results

## 11. CONCLUSION

The world is growing through a lot of problems currently. Some of these big problems the world faces include issues like Air pollution that is really very hazardous for all the living creatures on this planet. And sound pollution is also increasing with increase vehicles on the road, and the industrial sound pollution also is an important issue to be addressed. This project addresses the issue and provides a smart Internet-based solution that helps in monitoring the discussed issues.

International Conference on Computer Technology and Development, Kota Kinabalu, Malaysia, 13-15 November 2009. Vol. 2., IEEE Computer Society, 2009, pp. 494-496. IEEE Xplore, [ieeexplore.ieee.org.libproxy.murdoch.edu.au/stamp/stamp.jsp?tp=&arnumber=5360035](http://ieeexplore.ieee.org.libproxy.murdoch.edu.au/stamp/stamp.jsp?tp=&arnumber=5360035).

## ACKNOWLEDGEMENT

I would like to greatly express my gratitude towards my project guide, Mr. Rajesh Bhambare, for his constant help and motivation with the project. Mr. S.A. Shaikh is also to be praised for his timely help with this project several times. Mrs. Seema Arote has a special thanks to be mentioned for as she is the Head of Electronics department, and more than this, she helped and treated with all the love during all these times.

## REFERENCES

- [1] More Amruta, Patil Ashwini, Patil Rohit, Prof. Pritam. D.Desai, 'Raspberry Pi Based Air & Sound Pollution Monitoring System,' 13th international conference on recent innovation in science engineering and Management (ICRISEM), ISBN: 978-93-87793-02-6, ISSUE - 23th Feb 2018
- [2] Ms. Sarika Deshmukh, Mr . Saurabh Surendran, Prof. M.P. Sardey. 'Air and Sound Pollution Monitoring System using IoT', International Journal on Recent and Innovation Trends in Computing and Communication, ISSN: 2321-8169 Volume: 5 Issue: 6 175 - 178.
- [3] A.Rajasekar,R.V.Aadhithya., B.Gopinath., M.Mohammad Jaffar Ali., 'IoT Based Air And Noise Pollution Monitoring System', International Journal of Advanced Research Trends in Engineering and Technology (IJARTET) Vol. 4, Special Issue 19, April 2017, ISSN 2394-3785.
- [4] Palaghat Yaswanth Sai, 'An IoT Based Automated Noise and Air Pollution Monitoring System', International Journal of Advanced Research in Computer and Communication Engineering ISO 3297:2007 Certified Vol. 6, Issue 3, March 2017, ISSN (Online) 2278-1021.
- [5] Lalit Mohan Joshi, 'Research paper on IOT based Air and Sound Pollution Monitoring System', International Journal of Computer Applications (0975 - 8887) Volume 178 - No.7, November 2017.
- [6] Arnab Kumar Saha, Sachet Sircar, Priyasha Chatterjee, Souvik Dutta, Anwesha Mitra, Aiswarya Chatterjee, Soumyo Priyo Chattopadhyay, Himadri Nath Saha., 'A Raspberry Pi Controlled Cloud Based Air and Sound Pollution Monitoring System with Temperature and Humidity Sensing', Electrical & Electronics Engineering, Institute of Engineering & Management, Kolkata, India.
- [7] Zheng, Hongyan, et al. "Evaluation of Factors Affecting the Efficacy of English Acquisition in CALL Environment."