

Design of IOT Based and Hand Gesture Controlled Robot using MpU-6050 and NODEMCU

N.Trinadh Kumar¹, N.Neeraja², Amar Kumar Sharma³, Dr.Suman Maloji⁴

^{1,2,3}Student, Dept of Electronics and Computer Science Engineering, KL (Deemed to be UNIVERSITY),
Andhra Pradesh, India

⁴Professor, Dept of Electronics and Computer Science Engineering, KL (Deemed to be UNIVERSITY),
Andhra Pradesh, India

Abstract - Robotic Vehicle movement is with the hand movement gesture is difficult task in implementation. Monitoring of robotic system with human interaction is done by many researchers. But the system not performed well compare with other hand gesture systems. In this paper, an advanced robotic hand gesture system which is implemented with integrated system with advanced components. The design of the system is based on a simple, flexible and minimal control strategy. With the different types of gestures the system is developed to make easy use by the physically challenged people. In many of the applications this becomes the part.

Key Words: Gesture recognition, capturing of image, image processing and data extraction.

1. INTRODUCTION

Today robots are playing major role in various applications. There is lot of usage of robotics and it is increasing day by day. The robotics works on the instructions which are given by the user. The wireless human hand gesture is connected with the accelerometer. With the travelling of the user hand motion the robots travel according to the user instruction. The aim of the wireless hand control gesture system is implemented.

The implementation and design of advanced Wireless Gesture Controlled Robotic Hand with Vision consists of three parts such as Accelerometer, Robotic

Hand and Platform. This will controls the robotic wireless with the small and very low cost with the help of RF signals. This can also be controlled with wireless hand movement.

2. LITERATURE SURVEY

The author explains about the [1] "Improvement of hand motion acknowledgment sensor hooked in to quickening agent and spinner for controlling arm of submerged remotely worked robots". The hand signal sensor relies upon accelerometer and whirligig.

The author [2] described about the basic wearable hand motion gadget utilizing establishment of clinical and early current examinations. Cooperating with frameworks is finished with the help contact screen, wired or remote mouse and with the console. The individuals machine conveying gadget, most instinctive imparting gadget, to associates to the gadget and therefore the other apparatus.

The author explains [3] "embracing a wobot unusual? Examining the impact of robot appearance on client's view of embracing". Humanoid robots can collaborate with people utilizing physical association like embracing and handshaking.

The author explains [5] "A compact counterfeit mechanical hand constrained by EMG signal utilizing ANN classifier." The making a transportable robots for the truly moved people to try to to essential activities.

The author explains [6] "Dynamic sensor based constant robot way arranging utilizing motion and applaud sound."At present huge numbers of the indoor works like cleaning,object notoriety, etc.

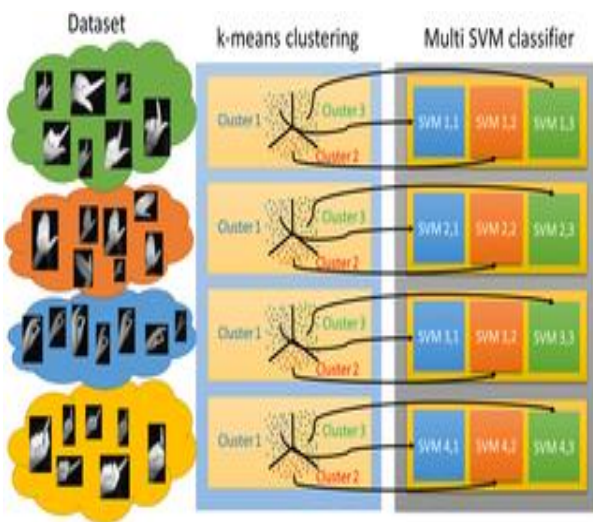

Fig-1: Accelerometer-based Gesture Recognition

3. THEORETICAL ANALYSIS

3.1 NodeMCU

This the open-source developed tool-kit integrated with firmware and it helps to develop the various IOT products. Based on the platform this system works and which is integrated with ESP8266 Wi-Fi SoC from Espressif Systems, and this is also based on module ESP-12. The language is Lua scripting language.

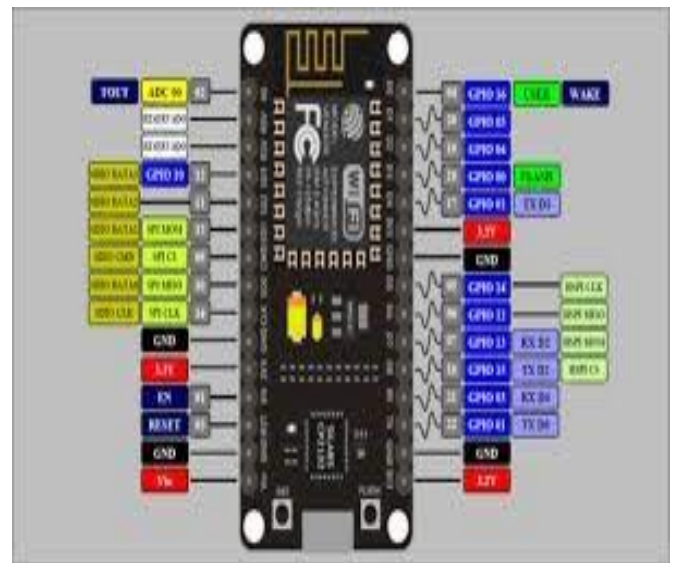

Fig-2: Description of NodeMCU



Fig-3: WIFI Module

3.2 Pins

NodeMCU provides access to the GPIO (General Purpose Input/Output) and a pin mapping table is part of the API documentation

Table-1: Description of Pins

I/O index	ESP8266 pin
0	GPIO16
1	GPIO5
2	GPIO4
3	GPIO0
4	GPIO2
5	GPIO14
6	GPIO12
7	GPIO13
8	GPIO15
9	GPIO3
10	GPIO1
11	GPIO9
12	GPIO10

3.3 MpU-6050

This is the one of the important part that will use motion tracking devices that are designed with the less power, less cost and better performance that require smart phones, tablets and wearable sensors.



Fig-4: MpU-6050

3.4 Lm298 Motor Driver

This is the driver that is having high voltage and huge power dual full bridge driver which is used to accept the standard TTL logic levels and drive inductive loads such relays, solenoids, DC and stepping motors. The inputs are enabled that are provided to enable or disable the device independently of the input signals.

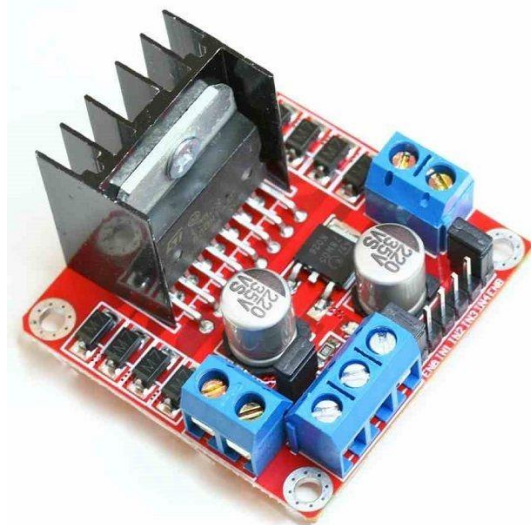

Fig -5: Lm298 Motor Driver

4. EXPERIMENTAL RESULTS



Fig-6: Gesture based controlled robot



Fig-7: ESP8266 Connection to MpU-6050



Fig-8: Upperview of Gesture Controlled Robot

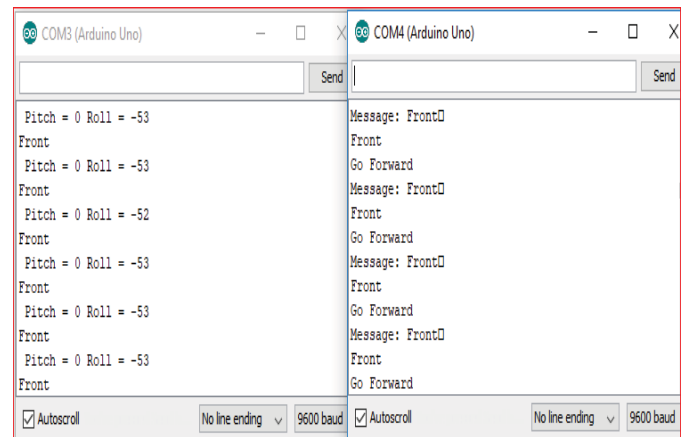

Fig-10: the integrated system for forward movement

5. CONCLUSIONS

In this paper, our approach is integrated with security surveillance has been described. The user can observe the real time images or live video footages around this designed system continuously. By using various integrated advanced components are utilized to improve the performance of the hand gesture controlled robot.

REFERENCES

[1] RiyazMansuri, SandeshVakale, AshishShinde, Tanveer Patel, "Hand Gesture Control Robot Vehicle", IJECT, Vol-4, Issue SPL-2, PP:77-80, 2013.

[2] Aswath S,Chinmaya Krishna Tilak, Amal Suresh and GaneshUdupa, "Human Gesture Recognition for Real – Time Control of Humanoid Robot", International Journal of Advance in Mechanical and Automobile Engineering (IJAMAE), Vol- 1, Issue 1,PP: 96-100,2014.

[3] Shruthi B.N, Shivraj, Sumathi S, "Hand Gesture Based Direction Control of Robocar using Arduino Microcontroller", International Journal of Recent Technology and Engineering (IJRTE), Volume -3, Issue-3, PP:32-35,2014.

[4] Vicky Somkuwar, RoshanGabhane, Sandeepkakde, "Design and Implementation of Gesture Controlled Robot Using Flex sensor and Accelerometer.

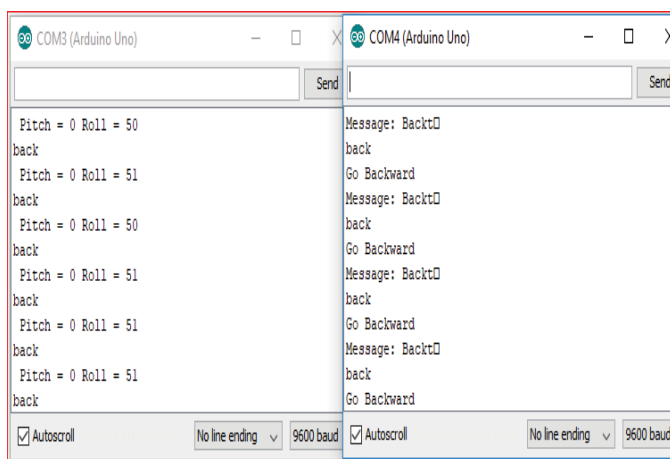

Fig-9: the integrated system for backward movement

[5] G. Baron, P.Czekalski, M.Golenia, K.Tokarz, "Gesture and voice driven mobile robot using Kinect sensor",IEEE, pp:33-34,2015.

[6] Le Thi- Lan, Nguyen Minh – Quoc, Nguyen Thi-Thanh – Mai,"Human posture recognition using human skeleton provided by Kinect", IEEE,pp:340-345,2013.

BIOGRAPHIES



N.Trinadh Kumar, Currently Studying in Koneru Lakshmaiah Education Foundation in ECM Department



AmarKumarSharma,Currently Studying in Koneru Lakshmaiah Education Foundation in ECM Department

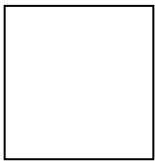

N.Neerraja, Currently Studying in Koneru Lakshmaiah Education Foundation in ECM Department



Dr.Suman Maloji, Currently Working as Professor in Koner Lakshmaiah Education Foundation.