

# IMPLEMENTATION OF REFURBISHED LITHIUM ION BATTERIES IN ENERGY STORAGE

K.Karunya Prabha<sup>1</sup>, Dr. R.Latha<sup>2</sup>

<sup>1</sup>PG Student, Electrical and Electronics Engineering, PSG College of Technology, Tamil Nadu, India.

<sup>2</sup>Associate Professor, Electrical and Electronics Engineering, PSG College of Technology, Tamil Nadu, India.

\*\*\*

**Abstract** - Now a day, smart grids suffer from peak demands of electricity, which pushes the utility companies to resort to fossil fuels to satisfy the peak demands. Fossil fuels, such as natural gas, are the main cause of the global warming. This paper is about the design and implementation of an ESS made from disposed electric vehicle (EV) li-ion batteries. These batteries can hold up to 80% of their initial rated capacity. The proposed ESS uses support vector machine and logistic regression method to analyze battery efficiency and load demand. The charging of the ESS happens at low demand of electricity or when the renewable resources have an output. The discharge happens when there is a peak demand.

for aerospace and automotive applications due to the above attributes, including the low price.

**Key Words:** Lithium ion batteries , Global warming, Disposed electric vehicle, Energy storage system(ESS), Battery efficiency, Load demand, Support vector machine, Logistic regression, Charging, Discharging.

## 1. INTRODUCTION

Today, scientists are most concerned about the green environment and environmental pollution threats. Based on cars, factories and manufacturing, the internal combustion engine (ICE) causes environmental pollution and global warming due to huge carbon gas emissions. Environmental researchers are paying attention to the development of electric vehicles (EVs) because EVs use electrical energy to operate motors efficiently. A simple electric vehicle system powered by the battery is shown in Fig.1 using a differential, mechanical transmission system, electrical motor, power converter, battery management system (BMS) and battery pack. The EV technology exhibits bidirectional energy flow during running and braking. Typically, electric vehicles can be categorized according to the power source as follows: purely hybrid electric vehicles (HEVs), battery-powered electric vehicles (BEVs), plug-in hybrid electric vehicles (PHEVs), photovoltaic electric vehicles (PEVs) and fuel cell vehicles (FCVs).

Because of their superior characteristics and advanced technology with the highest energy capacity, marginal storage effect and low self-discharge speed, Li-ion batteries have a potential world market compared to other batteries in different applications. Li-ion batteries are widely used as the primary or secondary source of energy in EVs and other devices. But, when charging and discharging, it needs security. Li-ion batteries will face significant future demand



Fig-1: Structure of an electric vehicle

EV systems may face trouble as the battery cells may reach a thermal runaway state due to exceeding the current, voltage and power limits. The Li-ion battery has become a more important subject in the research and development of power batteries and their use in EVs at the moment. More importantly, there are many different materials due to the use of graphic carbon as anodes that can be used as cathodes of Li-ion batteries. The analysis and evaluation of different types of Li-ion batteries based on the cathode materials is therefore elaborated.

Most of the researchers throughout the world are now concentrating on developing and modifying the lithium ion chemistry to achieve better performance considering the costs and other physical effects. The challenges for the management of battery charging and discharging within the ideal operating range of SOC have become more important topics for advanced research and technology. Now, the advancement of Li-ion battery production and application is growing beyond expectation. The manufacture of Li-ion batteries for vehicle applications is not common everywhere due to the necessary high technical support, management of raw resources and budget constraints. However, the governments of the most economically developed countries are concentrating on investing in installing battery industries because it is now possible to portably power vehicles without causing damages to the ecological systems. In this paper, the advantages and disadvantages of the most commonly used battery models are reviewed. In addition, a comparison study in the application of vehicles and current challenges and issues regarding Li-ion battery production

and action management with some recommendations are presented.

## 2. BATTERY MANAGEMENT SYSTEM

The Battery Management System (BMS) controls all the energy storage and transfer control and management facilities in EV systems such as charging and discharge control, battery cell voltage monitoring and balancing, equalization of battery charging, input / output current and voltage monitoring, temperature control, battery safety, fault detection and evaluation. Fig.3. Provides a description of BMS features. The BMS monitors battery charging according to the properties of the battery and the battery charging level. Depending on the load demand and the charge available in the battery systems, it regulates the discharge of the battery. The BMS needs to calculate the battery cell voltage levels to determine the battery cell charging status and to protect the cells from overcharging and undercharging. The BMS must incorporate the battery cell balancing by means of loading equalization techniques to improve the overall output and battery life. The BMS controls the operating temperature at certain levels to perform the energy conversions and manages the heat for safe operation. The protections from voltage/current stress, overvoltage, short-circuit, over current, hysteresis, etc., are affirmed by incorporating sensors, relays, and breakers in the BMS of EV systems. The BMS diagnoses and assesses the faults that usually take place in EV systems concerning the entire processes of energy storage and power delivery. The details are described as follows

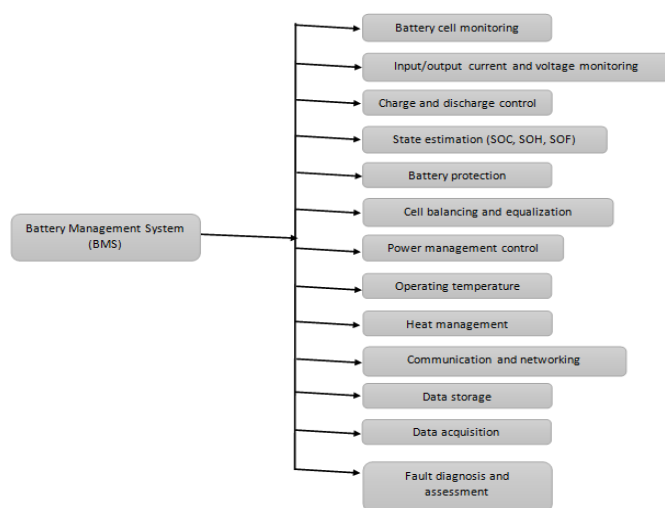

Fig -2: Characteristics of Battery Management System

Let us now discuss some parameters that are used to characterize batteries.

### 2.1 Voltage

The voltage at that the battery is rated is the nominal voltage at which the battery is supposed to operate. The so called

solar batteries or lead acid batteries for PV applications are usually rated at 12 V, 24 V or 48 V. The actual voltage of PV systems may differ from the nominal voltage. This is mainly depending on the SoC and the temperature of the battery.

### 2.2 Capacity

When talking about batteries, the term capacity refers to the amount of charge that the battery can deliver at the rated voltage. The capacity is directly proportional to the amount of electrode material in the battery. The capacity  $C_{bat}$  is measured in ampere-hours (Ah).

### 2.3 C-rate

The C-rate is used, which is a measure of the rate of discharge of the battery relative to its capacity. It is defined as the multiple of the current over the discharge current that the battery can sustain over one hour.

### 2.4 Battery Efficiency

For designing PV systems it is very important to know the efficiency of the storage system. For storage systems, usually the round-trip efficiency is used, which is given as the ratio of the total storage output to the total storage input.

### 2.5 Cycle lifetime

The cycle lifetime is defined as the number of charging and discharging cycles after that the battery capacity drops below 80% of the nominal value. Clearly, colder operating temperatures mean longer cycle lifetimes. Furthermore, the cycle lifetime depends strongly on the DoD. The smaller the DoD, the higher the cycle lifetime. Thus, that the battery will last longer if the average DoD can be reduced during the lifetime of the battery.

### 2.6 Temperature effects

While the battery lifetime is increased at lower temperatures, another effect must be considered. Lower the temperature, the lower the battery capacity. At higher temperatures, the chemicals in the battery are more active, leading to an increased battery capacity. At high temperatures, it is even possible to reach an above-rated battery capacity.

### 2.7 State of charge and depth of discharge

Another important battery parameter is the State of Charge (SoC), which is defined as the percentage of the battery capacity available for discharge,

Also the Depth of Discharge (DoD) is an important parameter. It is defined as the percentage of the battery capacity that has been discharged.

### 3. OVERVIEW ON LITHIUM ION BATTERY

#### 3.1 Development of Li-Ion Battery

With the continuous development in this technology, many different types of batteries have been developed. The "wet cells" were very common and used contained liquid electrolytes and metallic electrodes in an open container. This type of battery was reused by substituting the materials. Because they were not portable, early EVs utilized semi-sealed wet cells. In the early age of battery technology, the current was produced as the assembled battery; however, this battery could not be recharged electrically when the active elements were depleted. There was a remarkable breakthrough when the lead acid battery was invented with rechargeable types that could recharge the electric energy. It could store energy repeatedly and increase its lifetime. On the contrary, the Li-ion disposable battery has become increasingly popular in the rechargeable battery market because of its high energy density and long life although the price per unit is high.

#### 3.2 Construction

Li-ion batteries consist of two electrodes, such as the anode and the cathode, divided by an electrolyte separator where lithium ions travel from the cathode to the anode when charging and move back during discharge shown in Fig.4. Li-ion batteries use a compound lithium electrode material compared to non-rechargeable batteries containing lithium. Instead of the lead-acid battery with large lead plates and an acid electrolyte, Li-ion batteries have become more widely used as a compact rechargeable battery because they have a high density of energy and are lightweight in EV applications without any change in its drive system. Although Li-ion batteries have the best properties, they need high test conditions and protection during manufacturing and use due to the flammable electrolyte to avoid accident and failure.

#### 3.3 Characteristics

The important characteristics of Li-ion batteries include their size (physical and energy density), longevity (capacity and life cycles), charge and discharge characteristics, cost, performance in a wider temperature range, self-discharge profile and leakage, gassing, and toxicity impact. In general, lithium ion batteries have positive and negative traits. The positive traits include their high specific energy (230 Wh/kg) and power density (12 kW/kg), good energy density, excellent cycle life and long life, and good charging and discharging efficiency. The cost, the electronic protection system that is mandatory during charging and discharging and the GHGs emissions during manufacturing and disposal are common negative points. The Li-ion battery has good charging and discharging electrical characteristics, as shown in Fig. 5. While charging, the charging capacity increases gradually with the charge voltage maintaining a constant current.

#### 3.4 Components

The Li-ion battery is composed of four primary components including the cathode, anode, electrolyte and separator, as shown in Fig.4. The cathode is a lithium-metal-oxide powder. The lithium ions enter the cathode when the battery discharges and leave when the battery charges.

The anode is a graphitic carbon powder. The lithium ions leave the anode when the battery discharges and enter the anode when the battery charges.

The cathode and anode materials are made of lithium metal oxide and lithiated graphite in Li-ion batteries where both structures are organized in layer on aluminum and copper current collectors, respectively.

The electrolyte is composed of lithium salts and organic solvents; the electrolyte allows for the transport of the lithium ions between the cathode and anode rather than electrons. The separator is a micro-porous membrane that is used to rule out the short circuit between the cathode and anode and that only allows lithium ions to pass through the pores.

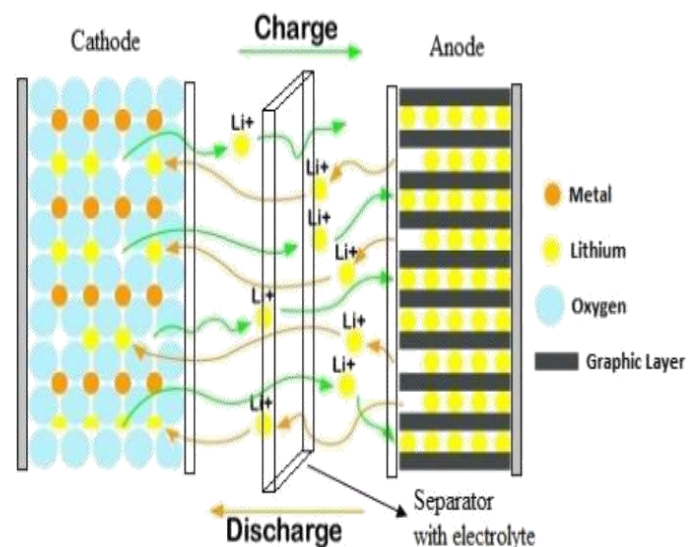

Fig-3: Charging and discharging phenomenon of Li-ion battery

#### 3.5 Battery Formations

Li-ion batteries can be constructed and packed in two major formations, which are metal cans either in cylindrical or prismatic shapes or laminate films (stacked cells) that are familiarized as Li-ion polymer batteries. Li-ion batteries can be shaped as the cylindrical structure of rolled and plastered layers in metal cans with electrolytes. A gel or polymer is often used to prevent the electrolyte from leaking in this package. For the energy source in EVs, Li-ion cells must be assembled into modules and then further composed into battery packs of series-parallel connected cells to achieve the precise energy demands.



### 3.6 Types of Li-Ion Batteries

In general, the main sources of the active lithium ions in a battery are the positive electrode material or the cathode. Hence, to achieve high capacity, a huge amount of lithium is included in this material. Additionally, cathode materials follow a reversible process to exchange the lithium with slight structural modifications to its properties; in the electrolyte, the materials are prepared from reasonably-priced high lithium ions that have diffusivity, good conductivity and high efficiency. Those types of cathode materials involve lithium cobalt oxide (LiCoO<sub>2</sub>), lithium manganese oxide (LiMn<sub>2</sub>O<sub>4</sub>), lithium iron phosphate (LiFePO<sub>4</sub>), lithium nickel- manganese-cobalt oxide (LiNiMnCoO<sub>2</sub>), lithium nickel cobalt aluminum oxide (LiNiCoAlO<sub>2</sub>) and lithium titanate (Li<sub>4</sub>Ti<sub>5</sub>O<sub>12</sub>).

### 3.7 Applications

Li-ion batteries are therefore a significant and appropriate applicant for the next generation of aviation, biomedical applications and new automotive applications, particularly new generation EVs and HEVs. Setting up a number of battery cells in series or parallel as a battery pack to power heavy electrical and electronic devices, such as EVs, HEVs, air-vehicles, automatic and remote-controlled systems, and other power tools and machinery, is more efficient and effective than connecting a huge battery capacity. Here, electric vehicle sales have gradually increased and production growth will continue in the future due to demand from the public for alternatives to traditional vehicles. Lithium-ion batteries often occupy a large field as a source of power in the telecommunications industries in addition to their use in automobiles. With proper handling, these batteries can be used for a secure backup power source for electric and electronic loads in an entire telecommunication network arena. In most cases, secondary non-aqueous Li-ion batteries are applied in these sectors. In some large size applications of Li-ion batteries, it is recommended that the regulatory requirements should be maintained to combat the explosion risk and to save the lives and environment by providing accurate instructions and information materials.

### 3.8 Performance Comparison

Table -1: Comparison of different types of batteries

BATTERY TYPE	LEAD-ACID	Ni-Cd	Ni-MH	Zn-Br	Fe-Cr	Li-ion
Energy Density(Wh/Kg)	30-50	45-80	60-120	35-54	20-35	110-160
Power Density	180	150	250-1000	-	70-100	1800
Nominal Voltage	2V	1.25V	1.25V	1.67V	1.18V	3.6V
Operating Temperature	-20-60°C	-40-60°C	-20-60°C	-20-60°C	-40-60°C	-20-60°C
Cycle Live	200-300	1500	300-500	>2000	-	500-1000
Charge Efficiency %	79	-	-	-	-	100
Energy Efficiency %	70	60-90	75	80	66	80
Voltage Efficiency %	-	-	-	-	82	-
Overcharge Tolerance	High	Moderate	Low	High	Moderate	Very Low
Self Discharge	Low	Moderate	High	Low	High	Very Low
Thermal Stability	Least Stable	Least Stable	Least Stable	Least Stable	Stable	Most Stable

### 4. ENERGY STORAGE SYSTEM

Nowadays, smart grids suffer from peak demands of electricity, which pushes the utility companies to resort to fossil fuels to satisfy the peak demands. Fossil fuels, such as natural gas, are the main cause of the global warming.

When electricity is generated, usually there is a mismatch between the demand from the customers and the generated power from the utility companies. They rely on fossil fuels for peak demand generation, in addition to nuclear power for the constant portion of the demand. The peak demand cannot be satisfied with renewable energy resources, such as wind power and solar energy, as these are heavily intermittent in nature. In order to alleviate the peak demand, most governments implement the so-called "peak shaving" in order to reduce the consumption of fossil fuels during the periods of high demands of energy.

Figure.5.shows the 20Ah li-ion cell degradation capacity. The estimated capacity is 16Ah after approximately 800 cycles.

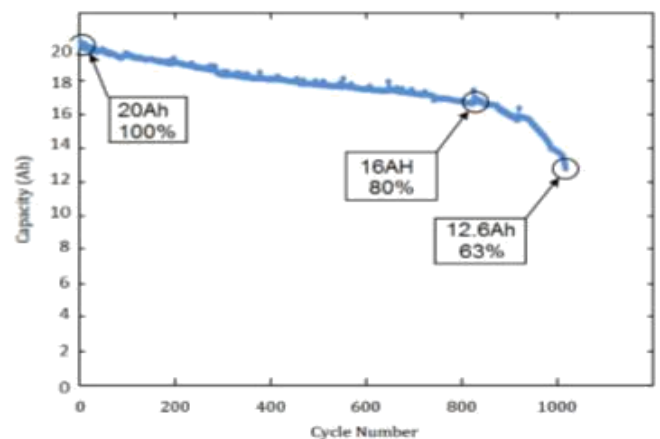

Fig-4: Li-ion battery degradation as function of cycle number

### 5. CONTROL FOR THE ESS

Figure.6. shows the control for the ESS. The charge/discharge mode of operation is decided by a micro-controller. A set relay switches are also controlled in order to provide an electric isolation between the batteries, the grid and the inverter that feeds the load.

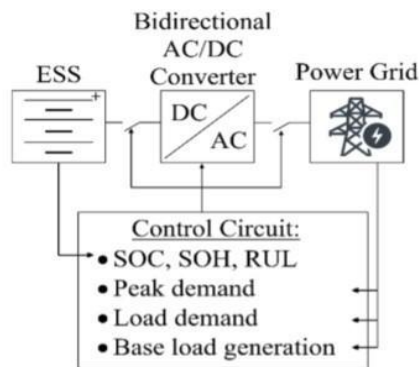

Fig-6: Control circuit for the proposed ESS

There are three types of sensors used to monitor the batteries within the ESS: temperature, current and voltage sensors. The controller takes input from highly non-linear components such as

### 5.1. The energy demand from the grid:

Advanced algorithms for demand forecasting were implemented in the microcontroller. The demand for energy is seasonal and highly variable. Data collection, data preparation, modeling, model evaluation, deployment and consumption is accomplished in a cloud environment.

### 5.2. State of charge (SOC) estimation:

The controller needs to know the amount of energy available in the ESS in order to activate their charging or discharging modes. A hybrid method for SOC estimation made of extended Kalman filter and Coulomb’s counting gives an accurate estimation values.

### 5.3. Remaining Useful Life (RUL):

In addition, the controller needs to have a good estimate of the remaining useful life (RUL) given that the battery cells are of the second hand, and some of the batteries may be in a more degraded status than other ones. There are several techniques used to have a good estimate the capacity fade rate of the highly non-linear li-ion battery cells. Support vector machines are well suited for RUL estimation. An initial State OF Health (SOH) estimation is useful to predict RUL.

### 5.4. Dynamic temperature control:

If the internal resistance of the li-ion battery cells is at the lowest levels, the ESS should be operated. The heat generated by ohmic losses then reduces the surface temperature of the battery cells. Excessive heat can result in thermal runaway and battery explosion. For the EV, several thermal battery management systems were developed. They differ in cost, technical solution, either active or passive, if using air or water, or using thermoelectric heat pumps of solid state.

## 6. SIMULATION MODULES

### 6.1 Module 1

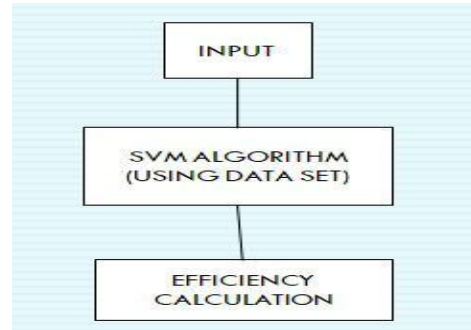

#### 6.1.1 Parameters Considerations

- State of Charge
- Input Current
- Output Current
  
- Output Voltage
- Load Level
- Temperature
- Usage of Time

### 6.2 Module 2

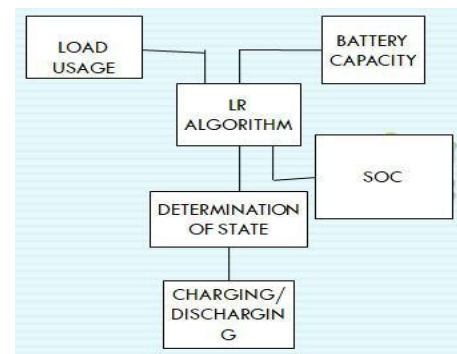

## 7. SIMULATION RESULTS

### 7.1 Battery Life

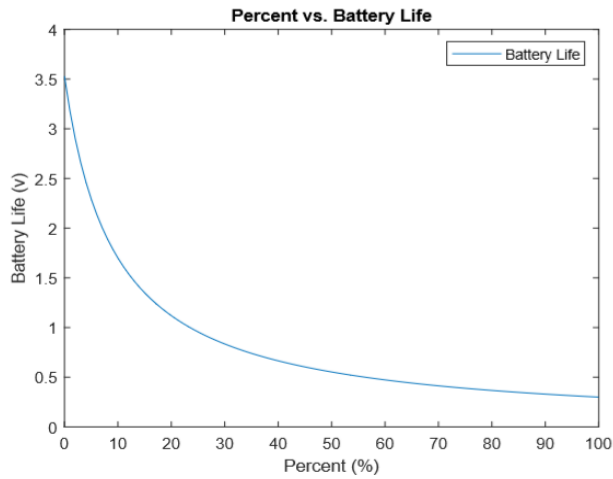

This above graph infer the charging characteristics of a lithium ion battery.

### 7.2 Battery Parameters

- Current
- Voltage
- Power

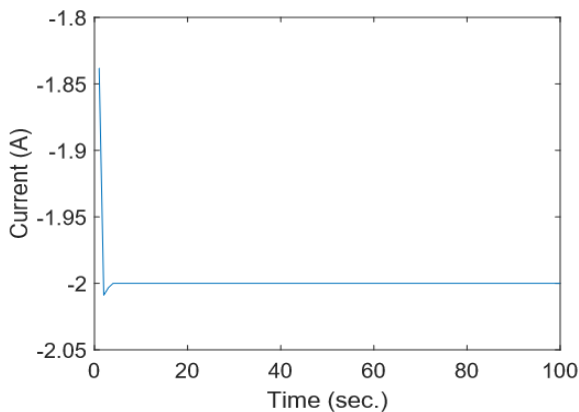

This below graph shows the current discharge rate of the battery.

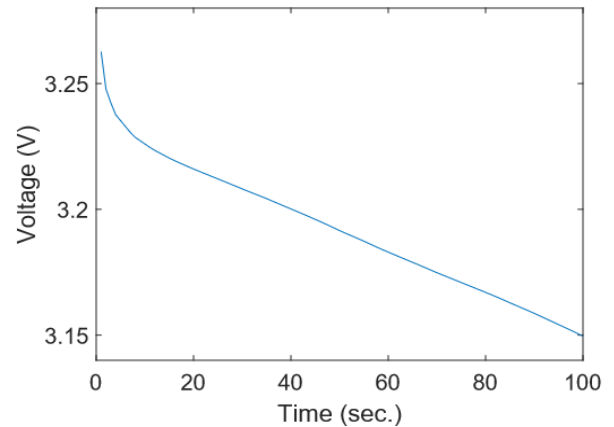

This graph shows the voltage during discharge with respect to time

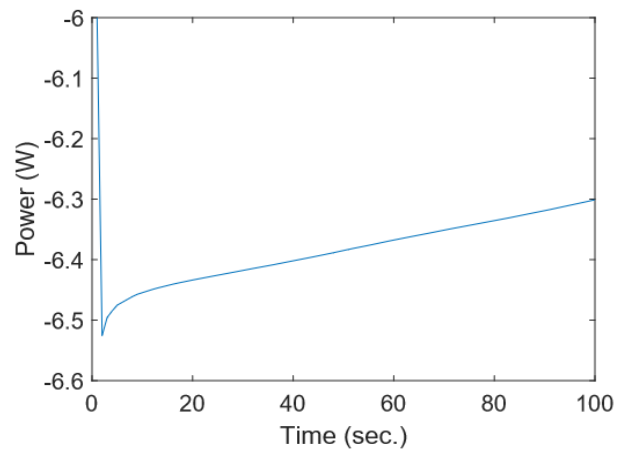

This graph shows the power discharge cycle with respect to time.

### 7.3 Battery State of Charge

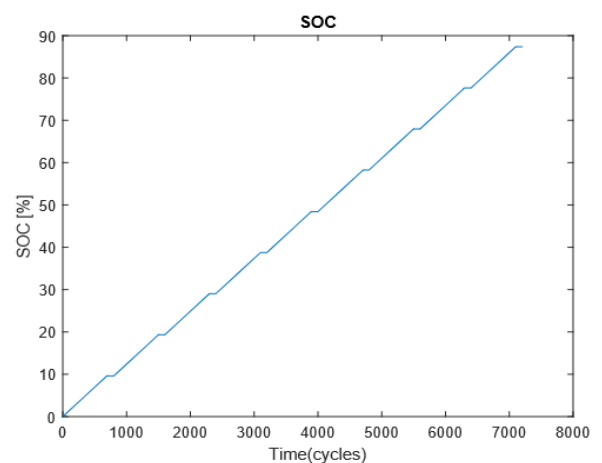

The above graph shows the SOC for charging of the battery.

## 8. CONCLUSION

In this paper, an energy storage system is developed to supply the arising demand in any low level applications. Its main purpose is to reduce the dependency on fossil fuels, especially during peak demands on electric energy, has been analyzed. ESS also stores energy from renewable sources, especially when their output is high. Exclusively, ESS uses refurbished li-ion battery cells of electric vehicles. It shows the implementation of support vector machine algorithm and logistic regression algorithm towards the load scheduling of the grid with refurbished EV li-ion batteries.

## REFERENCES

- [1] Chakib Alaoui, Mhamed Zineddine and Saidou Nourddin Insa "Towards the Implementation of Refurbished EV Lithium-Ion Batteries for Smart Grid Energy Storage."
- [2] M.A.Hannan, Senior Member, IEEE, M. M. Hoque, Student Member, IEEE, Aini Hussain, Yushaizad Yusof, P. J. Ker "State-of-the-Art and Energy Management System of Lithium Ion Batteries in Electric Vehicle Applications: Issues and Recommendations."
- [3] Mohamed Abdel-Monem, Omar Hegazy, Noshin Omar, Khiem Trad, Peter Van den Bossche and Joeri Van Mierlo "Lithium-ion Batteries: Comprehensive Technical Analysis of Second-Life Batteries for Smart Grid Applications."
- [4] Mehrdad ehsani, Yimin gao, Stefano longo, Kambiz M. Ebrahimi "Modern electric, Hybrid electric and Fuel cell vehicles."
- [5] Gregory L Plett "Battery Management Systems, Volume 1 Battery Modeling (2015, Artech House Publishers)."
- [6] K. T. Chau "Electric Vehicle Machines and Drives."
- [7] Bruno Scrosati, Jurgen Garche, Werner Tillmetz "Advances in Battery Technologies for Electric Vehicles (2015, Woodhead Publishing)."