

# SMART SOLAR HYBRIDE CLEANER

## AUTOMATIC AND PHONE CONTROLLED SOLAR GRASS CUTTER AND ROOM CLEANER

Suraj kumar,<sup>1</sup> Bhupendra Singh Niranjana,<sup>2</sup> Chandra Shekhar azad,<sup>3</sup> Arti Pandey,<sup>4</sup>

<sup>1</sup>UG Scholar, Dept. of EE, MGIMT, Lucknow, UP, India

<sup>2</sup>Assistant professor, Dept. of EE, MGIMT, Lucknow, UP, India

<sup>3</sup>Associate professor, Dept. of EE, MGIMT, Lucknow, UP, India

<sup>4</sup>Assistant professor, Dept. of EE, MGIMT, Lucknow, UP, India

\*\*\*

**Abstract:-** due to the continuous increase in the cost of fuel and the effect of emission of gases from the burnt fuel in to the atmosphere so that we use solar panel for this system. Because of the sun is the major source of energy for life on earth used for heat and lightning now a days solar energy has been known as a renewable resources such as sun, wind, and hydro

This report introduce a new development of hybrid cleaner named as smart solar hybrid cleaner

This hybrid cleaner is developed to reduce air pollutant and it also save our time. This grass cutter and including room cleaner is designed as remotely controlled and automatically controlled both by using arduino UNO .

Smart phone is used as the remote controller. The smart solar hybrid

Cleaner is reliable with high efficiency of the system compared that the system is reliable and environment friendly

**Keywords-** Smart Solar Hybrid cleaner, grass cutter, Room cleaner, Robot, Solar cutter, Automatic Cleaner, suraj kumar

### 1.Introduction

The conventional grass cutter and room cleaner the both are used separately the grass cutter is used by worker in the gardening and agricultural industries however, the manual handled grass cutter are consuming a lot of energy and producing air pollution the conventional grass cutter are also creating a high level of noise and vibration which can cause serious health issues, such as grip strength, decreased hand sensation. etc

In early time we use the grass cutter and room cleaner separately then it's too costly to buy one by one but by this mechanism we save our money and also environment

This is a smart solar hybrid cleaner based on automatic and phone controlling

This cleaner is clean room and also it cut grass powered by solar energy that also avoids obstacles and is capable of fully automated grass cutting and room cleaning without any human interaction

And it also controlled by mobile phone by using software the software of this system interact with mobile phone its start working

### 2. Literature Review

In this paper they have prepared phone controlled and automatic handle device which is capable to cut the grass and including room cleaning. This device consists of blades and it does not affected by climatic

conditions. And in this device also have a vacuum cleaner and room cleaning disc which is help us to dry cleaning and water cleaning They have used following components for preparing grass cutter and including room cleaner .If any obstacle comes in front of grass cutter then it sense by ultra sonic sensor and gives signal to the microcontroller to change the direction or stop the machine until the obstacle is removed. The main objective of this paper is to include in one grass cutter or room cleaner move the machine is different directions to prepare various designs as per requirements. By using link mechanism the height of the cut can be adjusted. The unskilled labor can easily operate this device.

Table No. 1-Component of Smart solar hybrid cleaner

Sr. No	Item	Quantity	Remark
●	DC motor	4	Rotating the wheel
●	DC motor	4	To lifting machine or adjusting blade size for cutting the grass
●	DC motor	1	For vacuum cleaner
●	DC motor	1	For controlling floor cleaning disc
●	DC motor	1	Rotating the blade

6.	Wheel	8	Moving the robot
7	Battery	1	Power supply
8.	Solar panel	1	Power supply for batteries
9	Ultra sonic sensor	1	Obstacle detection
10.	Rain sensor	1	By using lift the robot
11.	Buzzer	1	For inform human
12.	LED strip	1	For visible in night

13.	Water pump	1	For spread water on floor
14.	HC-05 Bluetooth	1	For remote controlling
15.	Motor drive	3	To control motor

### 3. OBJECTIVE

The objective of the project is to design the smart solar hybrid cleaner which operates upon solar energy and it also avoid obstacles.

The purpose is to avoid fuel consumption and reduce the human effort, operating cost, maintenance cost.

Also solar based hybrid cleaner are environmental friendly it is used for various application.

The whole machine operates on the solar energy which is stored in battery

Our project is a battery powered automatic and phone controlled grass cutter and room cleaner include in one machine

It will have a solar powered charging station that is use to give charging power to battery and battery gives power to motor and motor helps to process grass cutting and room cleaning

In this project have a vacuum cleaner which helps to clean dust

In this hybrid cleaner have a lifting technology which helps to body puss on the upward direction when water droplet dropped on machine to protect the blade from junk

Room cleaner is use four shook observer arm which is connected with cleaning disc

Automatically it will shut off when finish it work

To reduce the cost of early grass cutter and room cleaner which is work on separately.

It can be operated by unskilled person

#### 4. Flow chart

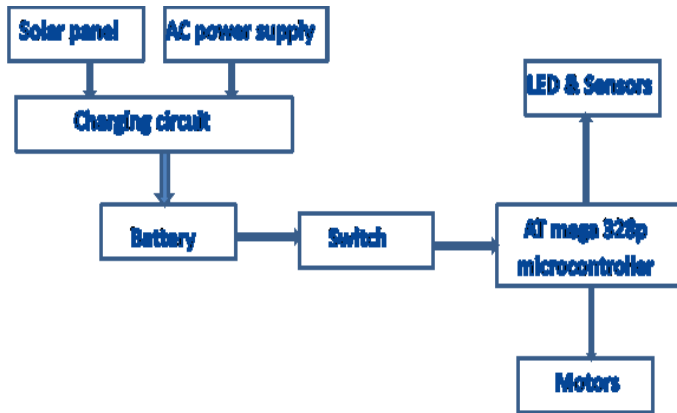

Fig. 1: flow chart

#### 5. Components description

##### ➤ ARDUINO AT mega 328 MICROCONTROLLER

The Arduino Uno is an open-source microcontroller board based on the Microchip ATmega328P microcontroller and developed by Arduino.cc. The board is equipped with sets of digital and analog input/output pins that may be interfaced to various expansion boards and other circuits

##### ➤ DC motor

DC Gear motor, is also called DC Geared Motor, Geared Dc Motor and gearhead motor or gearbox motor. It consists of a electric DC motor and a gearbox or gearhead; these gearheads are used to reduce the DC motor speed, while increase the DC motor torque. Therefore user can get lower speed and higher torque from gear motor.

##### ➤ Solar energy

Solar energy is radiant light and heat from the sun harnessed using a range of ever-evolving technologies such as solar heating, solar photo voltaic, solar thermal energy, solar architecture and artificial photosynthesis. Solar energy is verylarge, inexhaustible source of energy. The power from the sun

interrupted by earth is approximately 1.8/10MW, which are many thousands of times larger than the present consumption rate on the earth of all energy sources.

##### ➤ Motor drive (L293D)

L293DIC:L293D is a dual H-bridge motor driver integrated circuit (IC).Motor drivers act as current

amplifiers since they take a low-

Current control signal and provide a higher-current signal. This higher current signal is used to drive the motors.L293D contains two inbuilt H-bridge driver circuits. In its common mode of operation, two DC motors can be driven simultaneously, both in forward and reverse direction.

#### Block diagram

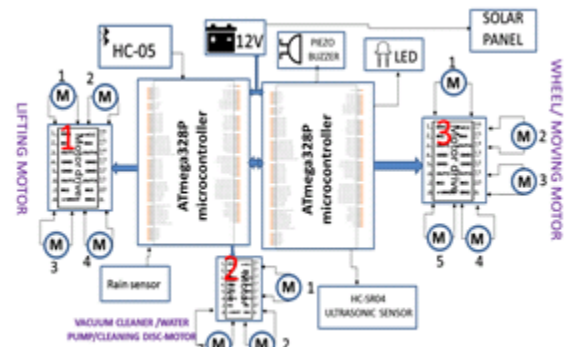

Fig:-2 Block diagram of smart solar hybrid cleaner

#### 6. Working of hybrid cleaner

Our project proposes a robotic vehicle that can be operate automatically by using given command the C emended language is use in this project to operate automatically and this project is also handled remotely through an android based device. The control device is integrated with a Bluetooth device that allows capturing and reading the commands. The robotic vehicle may then be operated as desired as commanded through the android application. The vehicle is integrated with a microcontroller of AVR

family that is used to operate the vehicle as per android commands. The controlling device may be any android based Smartphone/tab etc. having an android OS. The android controlling system provides a good interactive GUI that makes it easy for the user to control the vehicle. The transmitter uses an android application required for transmitting the data. The receiver end reads these commands and interprets them into controlling the robotic vehicle. The android device sends commands to move the vehicle in forward, backward, right and left directions. After receiving the commands, the microcontroller then operates the motors in order to move the vehicle in four directions. The communication between android device and receiver is sent as serial communication data. The microcontroller program is designed to move the motors through a motor driver IC as per the commands sent by android device.

### 7. POSSIBLE EXTRA FEATURE

- Automatic its body will go upward direction in rainy season by using lifting mechanism
- lifting mechanism helps to protect the cutter blade from corrosion and it will also help to adjust grass cutting size
- In cleaning disc we use four auto adjustable arms (shock absorber) which helps to give better performance in up and down place



### 8. ADVANTAGES

- Compact size and portable
- No fuel cost
- No pollution
- Easy to move from one place to another place
- Non-skilled person can also operate

- It has the ability to do both work: Room cleaning and grass cutting
- Due to solar panel it cannot consume electric bill

### 9. Future Scope

- Size can be reduced to make it compact. Efficiency can be improved by increasing the battery capacity
- We can upgrade lifting mechanism to give much better performance.

### • CONCLUSION

It works on dc power supply which is given by 6-12v battery that consists renewable source of energy so total energy received from sun is a better option to protect our environment

By using simple interface that is based on android application we can easily handle our robot to do work and in this device also have automatic program to work without any human existence simply on the switch and machine will automatically do their work which is already defined in microcontroller and it removes human effort or non-skilled person handle it easily. By using simple switches or by predetermined programming it can be easily handled and controlled within less time. It is highly efficient and accurate because it detects the obstacle and changes the direction or stop functioning as per the instruction given. Therefore equipment should be protected from damage and reduces risk on human

It has a unique technology that helps to automatically up and down machine in rainy session which is retract blade from rust and also we adjust grass cutting size

## 10. References

1. Jens-Steffen Gutmann, Kristen Culp, Mario E. Munich and Paolo Pirjanian. The Social Impact of a Systematic Floor Cleaner. In IEEE international workshop on advance robotics and its social impacts, Technische University munchen, Germany May 21-23, 2012
2. Srishti Jain, Amar Khalore, Shashikant Patil. Self-Efficient and Sustainable Solar Powered Robotic Lawn Mower in International Journal of Trend in Research and Development (IJTRD). Vol.2 (6), December 2015.
3. Ms. Rutuja A. Yadav, Ms. Nayana V. Chavan, Ms. Monika B. Patil, Prof. V .A. Mane. Automated Solar Grass Cutter in International Journal of Scientific Development and Research(IJSDR). Vol.2, February 2017.
4. Ms. Bhagyashri R. Patil, Mr. Sagar S. Patil. Solar Based Grass Cutting in International Journal of Electrical and Electronics Engineers (IJEEE). January-June 2017.
5. Ashish Kumar Chaudhari, Yuvraj Sahu, Pramod kumar Sahu, Subhash Chandra Verma, Smart Solar Grass Cutter Robot for Grass Trimming, International Journal of Advance Research and Innovative Ideas in Education, Vol. 2, 2016, 1246-1251.
6. Vicky Jain, Sagar Patil, Prashant Bagane, Prof. Mrs. S. S. Patil, Solar Based Wireless Grass Cutter, International Journal of Science Technology and Engineering, Vol. 2, 2016, 576-580.
7. Pankaj Malviya, Nukul Patil, Raja Prajapat, Vaibhav Mandloi, Dr. Pradeep Kumar Patil, Prof. Prabodh Bhise, Fabrication of Solar Grass Cutter, Internatinal Journal of Scientific Research in Science, Engineering and Technology, Vol. 2, 2016, 892-898
8. Ms. Lanka Priyanka, Mr. Prof. J. Nagaraju, Mr. Vinod Kumar Reddy, Fabrication of Solar Powered Grass Cutting Machine, International Journal and Magazine of Engineering, Technology, Management and Research, Vol. 2, 2015, 386-390.
9. Sachin Prabha,Dattatray G. Biradar, Sachin Panshette,Veernehadrappa, Solar Grass Cutter Machine, International Journal For Technological Research In Engineering, Vol. 3,2016, 2702-2706.
10. Tanimola, O. A. Diabana, P. D and Bankole, Y. O., Design and Development of Solar Powered Lawn Mower, International Journal of Science and Engineering Research, Vol. 5, 2014, 215-220.
11. Ashish Kumar Chaudhari, Yuvraj Sahu, Prabhat Kumar Dwivedi, Harsh Jain, Experimental Study of Solar Power Grass Cutter Robot, , International Journal of Advance Research and Innovative Ideas in Education, Vol. 2, 2016, 68-73.
12. Praful P. Ulhe, Manish D. Inwate, Fried D. Wankhede, Krushnkumar S. Dhakte, Modification of Solar Grass Cutting Machine, International Journal for Innovative Research in Science & Technology, Vol. 2, 2016, 711-714