

# RECOVERY OF ENERGY FROM EXHAUST AIR OF TEXTILE INDUSTRY WITH THE HELP OF VAWT

Saurabh Singh<sup>1</sup>, Patel Aakash S.<sup>2</sup>, Patel Ankit K.<sup>3</sup>, Prajapati Neeraj L.<sup>4</sup>, Rao Jeet D.<sup>5</sup>, Prof. Pritesh Prajapati<sup>6</sup>

<sup>1,2,3,4,5</sup>(U.G.) Students, Department of Mechanical Engineering, K.I.T.R.C, Kalol, Gujarat, India

<sup>6</sup>Professor, Dept. of Mechanical Engineering, K.I.T.R.C, Kalol, Gujarat, India

\*\*\*

**Abstract** - In the current world, coal and petroleum are constantly depleting with the increase in population of world. Hence it is essential to have renewable sources which have no harmful effect on environment. Therefore, we are introducing an innovative concept of recovering energy from exhaust air from AC outlet of textile industry with the help of vertical axis wind turbine. It will convert kinetic energy of exhaust air into energy production with the help of gearbox, generator, rectifier etc. Designing the duct and VAWT to give optimum output will be the main focus of our project.

**Key Words:** exhaust air, power generation, vertical axis wind turbine, clean energy

## 1. INTRODUCTION

As the population is increasing exponentially, there is an increase in demand of more and more energy resources and due to which non-renewable resources are constantly becoming scarce and more expensive. Hence to meet these escalating demands, several measures have been taken up to improve various existing technologies. Also, researchers and environmentalist have started to look upon new approaches which will result in shifting of energy resources from conventional sources of energy to non-conventional sources of energy. But by looking into current scenario, India is largely dependent upon conventional source of energy which is basically derived from fossil fuels. These fossil fuels are limited and will get quickly exhausted in near future, if not, checked. But, one such fossil fuel upon which India is hugely dependent is coal and coal accounts of 74.5% of whole electricity generation. This electricity generated in India with the help of fossil fuels also has huge adverse effect on environment. Burning of fossil fuels produces tonnes of CO<sub>2</sub> emission in the environment which has detrimental effect on public's health and to the nature itself and the most worrying thing about it is that India's emission is growing rapidly in upcoming years and along with it India has produced more CO<sub>2</sub> emission in recent years than some of the most developed countries.

But government has taken several measures to lower the over-dependency on fossil fuels by switching to renewable energy resources by introducing new technologies to harvest energy from renewable sources.

Government has emphasized more strongly on utilisation of renewable source of energy. So, to encourage or promote

this initiative taken up by government will be our main inspiration for this project. Hence, our project clearly demonstrates of using renewable source of energy to produce electricity.

But our main objective is to bring this project to the industrial region where it is much needed. But it is very much difficult to implement in the industrial areas as there are no open areas (due to closed packed buildings) for wind to travel at high speed as compared to wind travelling in coastal areas or in large acres of empty land.

So, this challenge is going to give us a very much clear perspective of how we are going to use this project and implement it in the industrial areas.

Our project will show that how we are going to utilize the exhaust air generated from exhaust outlet which are present in the industries to produce electricity.

There are several different types of industry such as chemical industries, automobile industries, textile industries, cement industries, steel industries, mining industries, software industries and many more...but we have selected textile industries for implementing our project due to following reasons: -

(1) Textile industry in our country is the second in global textile manufacturing and shares 63% of global textile and garment market.

(2) The textile industries are in the form of small factories or SMEs which produces finished goods and products. But along with-it factories produce tonnes of exhaust air without knowing its full potential.

So, we are using exhaust air as a substitute of wind to produce electricity which will be helpful for small factories to become independent from other sources of electricity such as coal, gas, oil etc. This will help industry to generate energy from waste (exhaust air). It will also help in addressing the issue of huge CO<sub>2</sub> emission.

We will produce electricity with the help of Savonius wind turbine which is placed in front of exhaust air passing from exhaust outlet. Due to the aerodynamics of turbine blades it starts to rotate and electricity is generated with the help of generator.

This project will help in studying the optimum design of duct and VAWT. Aerodynamic behaviour of VAWT is presented

with the help of simulation and later on modification would be given to increase the productivity.

### 1.1 Aim and Objective of the project

- Our aim is to reduce our dependency upon the conventional energy of sources and fully utilizing the non-conventional energy of sources to its potential. We have to use non-conventional sources of energy such as wind energy, solar energy, tidal energy, hydro energy, bio-gas energy etc.
- Hence, our project comprises of demonstration of generation of power from exhaust air with the help of wind turbine.
- But our main objective is to bring this project to the industrial region where it is much needed.
- As it is very much difficult to implement in the industrial areas because there are no open areas (due to closed packed buildings) for wind to travel at high speed as compared to wind travelling in coastal areas or in large acres of empty land.
- Our objective is to fully utilize the exhaust air as the industries produces lot of exhaust air in many different forms, which in turn, gets dissipated in the environment, wasting their full potential.
- This project shows a more effective way to use the exhaust air in the form of non-conventional energy source to recover energy from it to produce electrical output.
- The electricity obtained from this recovery system will be used in several forms such as:
  - (1) For electrification in rural areas.
  - (2) For transforming urban areas into more greener cities.
  - (3) Providing cheaper electricity.
  - (4) Improving lives of people living in tribal areas.
  - (5) For industrial purposes.

### 1.2 Materials/Tools required

- For designing:
  - Autodesk Fusion 360
  - Auto CAD
- For simulation:
  - Autodesk Fusion 360
  - Ansys Workbench 2019 R3
- Components:
  - Duct
  - Vertical Axis Wind Turbine (VAWT)
  - Generator
  - Rectifier
  - Battery
- For measuring:
  - Vane anemometer (to measure wind speed)
  - Tachometer (to measure turbine speed)

- Ammeter (to measure current)
- Voltmeter (to measure voltage)

### 1.3. METHODOLOGY

The goal of the project is to design a system which will convert the kinetic energy of exhaust air into electricity.

To accomplish this goal, the main objectives were to:

- (1) Analyse the actual air speed data at the fan outlet and calculate average speed value, and volume flow rate of exhaust air.
- (2) Secondly, we have to design the duct accordingly with the exhaust air speed data that we have collected and increase the speed of exhaust air.
- (3) Calculate the speed of turbine which will be in relation with the exhaust air velocity.
- (4) Calculate the electrical power output from the wind turbine.

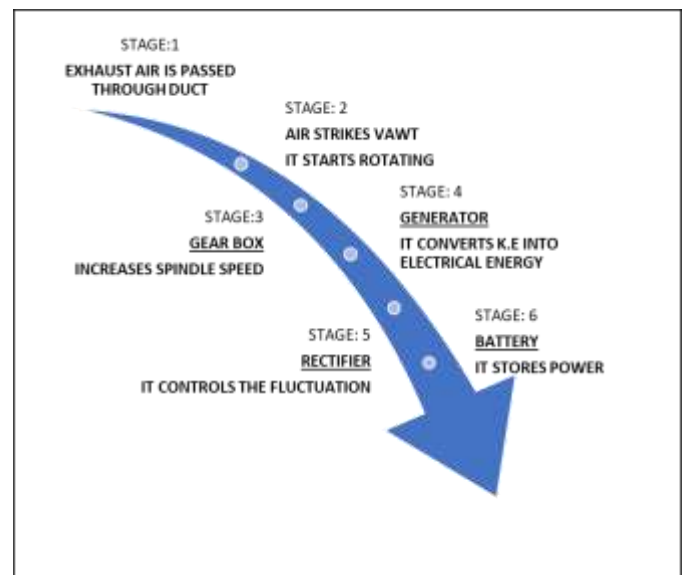

Figure 1 Design Layout

## 2. DESIGN

### 2.1 Calculation of average exhaust air flow rate

Since the exhaust air at the outlet keeps changing as it is influenced by so many factors. Hence it makes it as a complicated model.

Therefore, to calculate average speed of exhaust air the circular outlet duct is divided into 3 concentric parts of equal areas and 12 points have been measured using vane anemometer.

$$V_{avg} = (V1 + V2 + V3 + V4 + \dots + V12) / 12$$

where,  $V_{avg}$  = average exhaust air speed at the exit of duct take,  $V_2 = V_{avg}$  ----- (eq. 1)

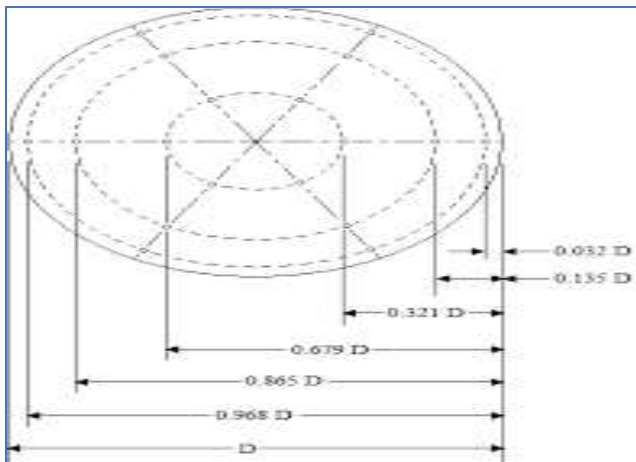

Figure 2 outlet of exhaust fan

### 2.2 Calculation of duct design

(1) The duct arrangement shape is particular designed to produce venturi effect.

(2) The duct is so designed to correct air flow profile and maintain a venturi effect to increase the air speed for optimum result.

(3) So, to achieve this we have designed circular duct at the inlet and after going along the flow of exhaust air cross section of duct becomes conical in the between so as to create venturi effect at outlet of duct.

So, applying continuity equations at inlet and outlet of duct we will get as follows:

$$A_1 V_1 = A_2 V_2$$

$$A_1 V_1 = A_2 V_2 \text{ --- (since, } V_2 = V_{avg} \text{)}$$

where,

$A_1$  = cross sectional area of inlet

$V_1$  = exhaust air velocity at inlet

$A_2$  = cross sectional area of outlet

$V_2$  = exhaust air velocity at outlet

Hence, we can calculate the area of duct at the outlet of exhaust air.

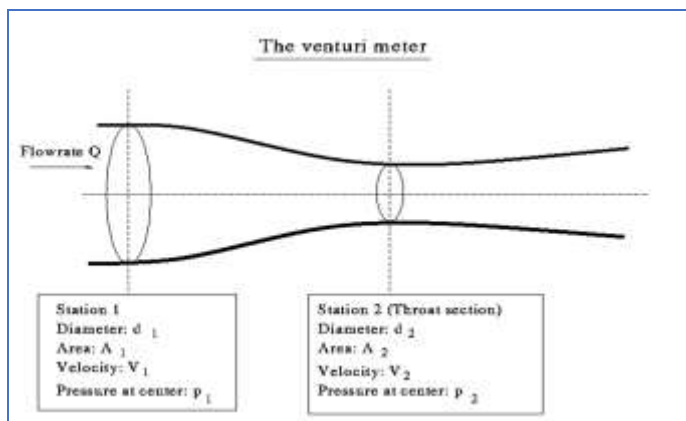

Figure 3 Venturi Duct

### 2.3 Calculation of design of wind turbine

There are different types of wind turbine available commercially.

They are classified into 2 types:

(1) Horizontal axis wind turbine

(2) Vertical axis wind turbine

Furthermore, in vertical axis wind turbine it is classified into several types such as:

(1) Savonius turbine

(2) Darrieus turbine

(3) Cup rotor turbine

We chose Savonius turbine because it has lot of benefits such as:

(1) It is simple and cheap to construct.

(2) It has low noise and angular velocity.

(3) It can accept wind from any direction.

(4) It can operate in turbulent winds.

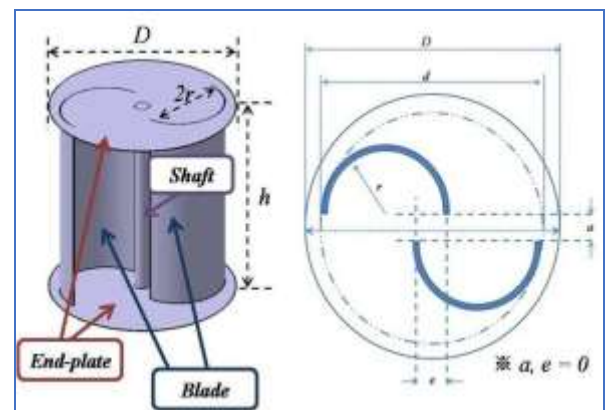

Figure 4 Savonius wind turbine

#### 2.3.1 Wind Turbine design parameters:

PARAMETERS	VALUES
(1) Diameter of turbine	550 mm
(2) Height of turbine	400mm
(3) Thickness of blades	10mm
(4) Diameter of shaft	40mm
(5) Length of shaft	500mm
(6) No. of blades	2

(1) Swept area of turbine

(2) Tip Speed ratio

(3) Drag coefficient

(4) Moment coefficient

(5) Power coefficient

(6) Betz's Law

(7) Power generated by turbine

(8) Speed of turbine

#### 2.3.2 SWEPT AREA: $A = D * H$

Where, D= diameter of the wind turbine

H= height of turbine

#### 2.3.3 TIP SPEED RATIO: $T.S.R = (\omega R/V)$

Where,  $\omega$  = Angular velocity of turbine

R = Radius of turbine

V = Velocity of turbine

**2.3.4 DRAG COEFFICIENT:  $C_d = (F_d / 0.5\rho AV^3)$**

Where,  $F_d$  = Drag force

$\rho$  = Density of air

A = Swept area

V = Velocity of air

**2.3.5 MOMENT COEFFICIENT:  $C_m = (M / qSc)$**

Where, M = pitching moment

q = dynamic pressure

S = blade area

c = length of blade

**2.3.6 POWER COEFFICIENT:  $C_p = (P_m / 0.5\rho AV^3)$**

Where,  $\rho$  = density of air

A = area of turbine

V = velocity of air

**2.3.7 THEORETICAL POWER CALCULATION**

$$E = (1/2) Mv^2$$

Differentiating above eq. we get

$$P = (dE/dt) = (1/2) V^2 (dm/dt) \text{ --- eq. (1)}$$

Since we know,  $m = \rho * A * x$

$$(dm/dt) = \rho * A (dx/dt)$$

Also,  $(dx/dt) = V$

$$\text{We get, } (dm/dt) = \rho AV \text{ --- eq. (2)}$$

Putting above eq. (2) in eq. (1) we get

$$P = (1/2) \rho AV^3$$

**2.3.8 BETZ'S LAW:**

Betz's law indicates the maximum power that can be extracted from the wind, independent of the design of a wind turbine in open flow.

According to Betz's law, no turbine can capture more than 16/27 (59.3%) of the kinetic energy in wind. The factor 16/27 (0.593) is known as Betz's coefficient. Practical utility-scale wind turbines achieve at peak 75–80% of the Betz limit.

$$\therefore P_{max} = (16/27) * 0.5 * \rho * S * v_1^3$$

**2.3.9 SPEED OF TURBINE:  $V = (2\pi RN/60)$**

Where, R = radius of wind turbine

N = number of blades

V = velocity of turbine

**3. SIMULATION**

We have simulated our model into 4 different parts using Ansys Workbench 19.0 R3.

- (1) 3D model of Savonius wind turbine.
- (2) Aerofoil of the turbine.
- (3) Static structural analysis of turbine.
- (4) Air duct.

For creating simulation, we have to first create project schematic by dragging one of the required analysis systems (in our case for 3D model & aerofoil is fluid flow (fluent))

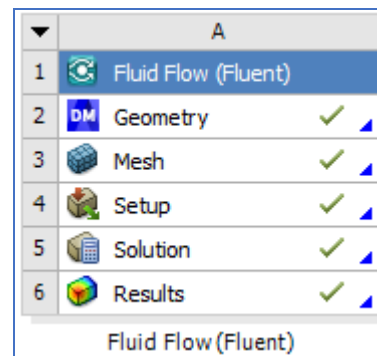

Figure 5 Project schematic

**(3.1) 3D MODEL**

So, in our first step after creating project schematic we have to make model of our project in design modeler software which is already present in ANSYS 19.0 workbench.

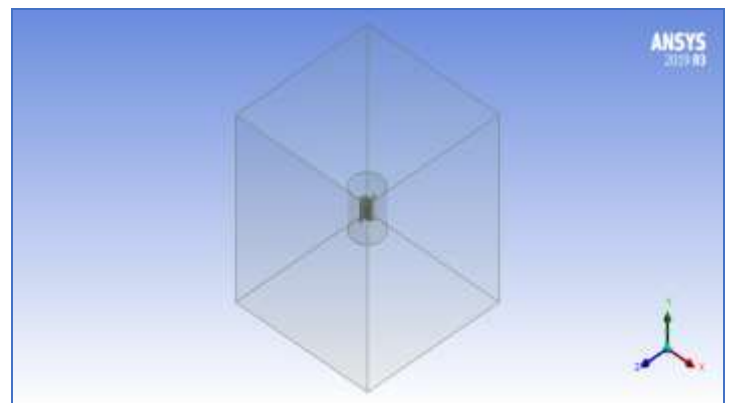

Figure 6 3D model of Savonius wind turbine

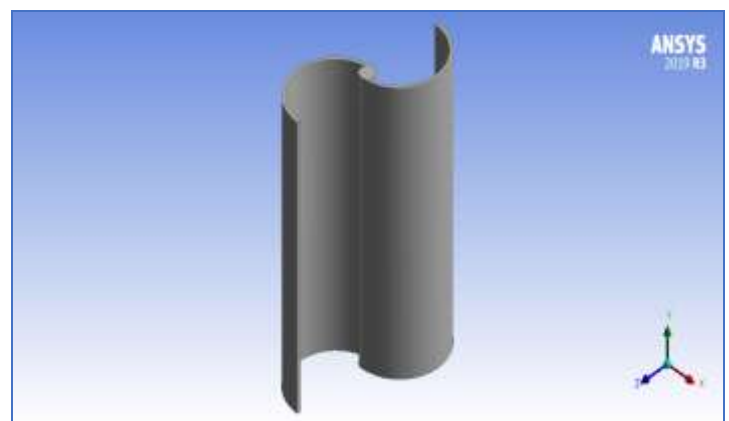

Figure 7 closer view of turbine





Figure 8 airfoil of turbine

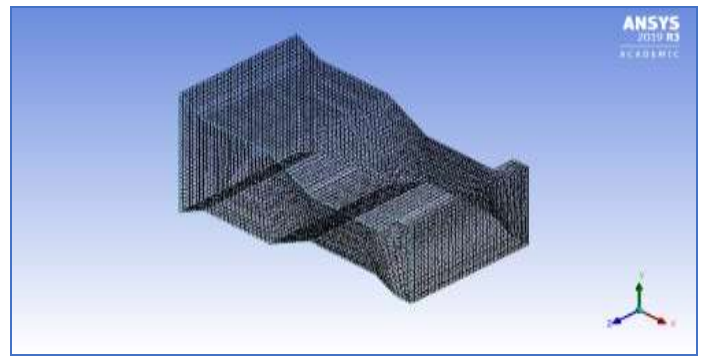

Figure 12 meshing of duct

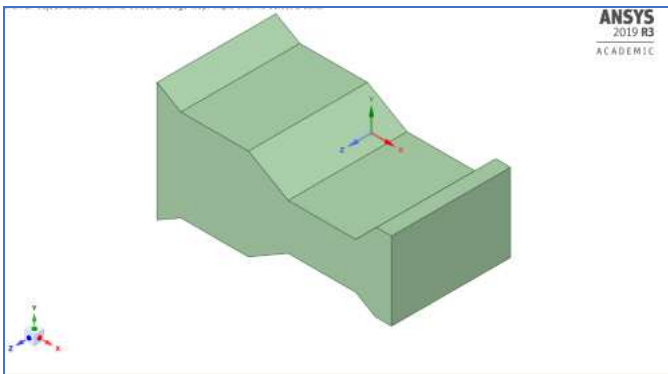

Figure 9 3D duct model

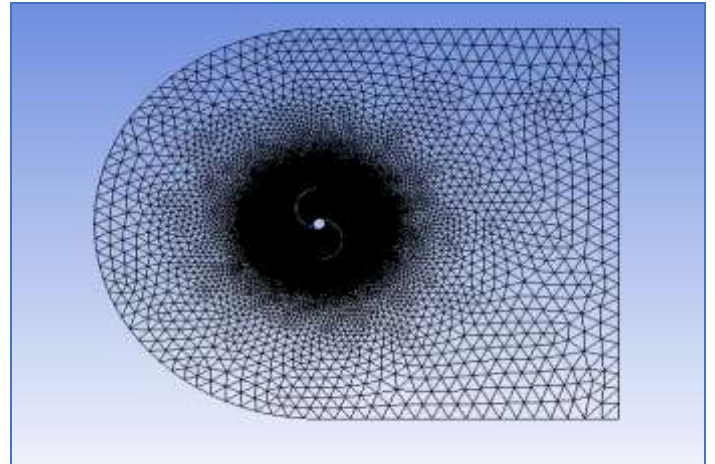

Figure 13 meshing of airfoil

### (3.2) MESHING

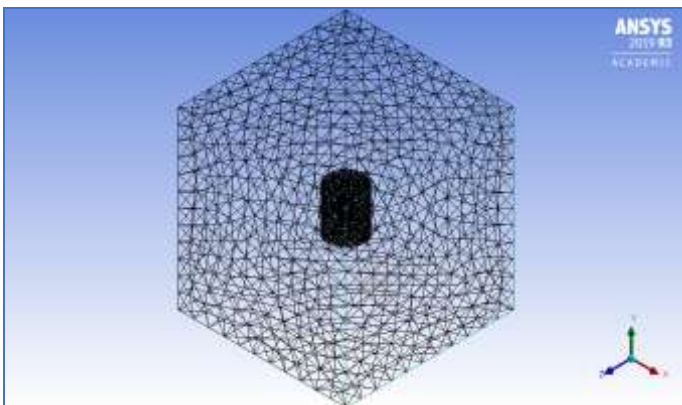

Figure 10 meshing of 3D Savonius wind turbine

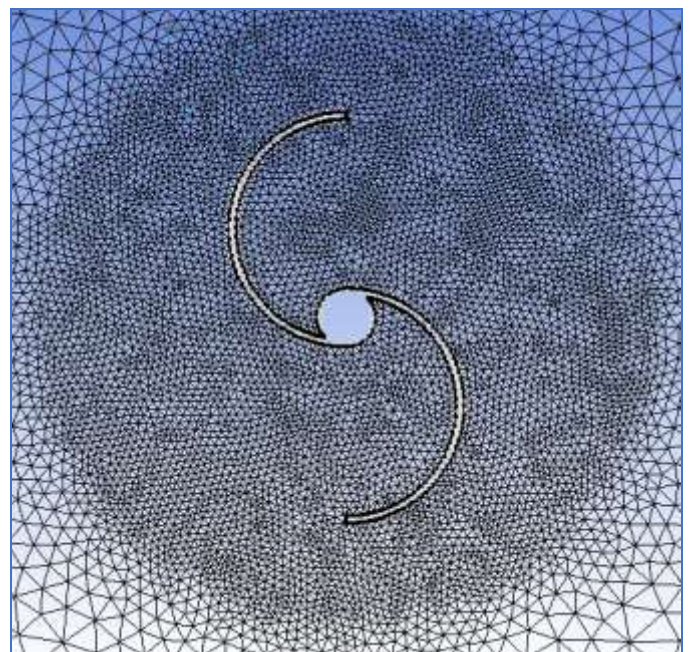

Figure 14 closer view of meshing

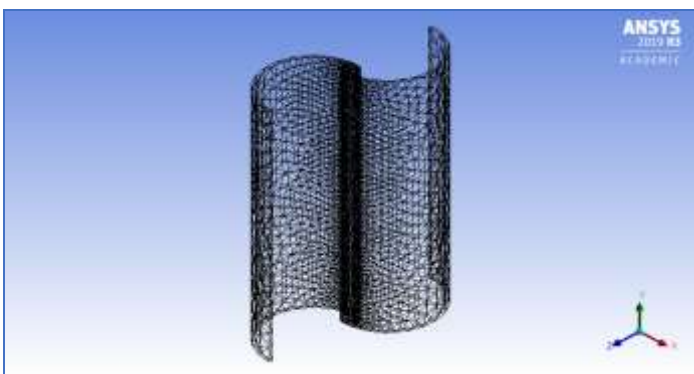

Figure 11 meshing of turbine blades

### (3.3) SETUP

Here we are going to present the whole setup of our model. The setup consists of selecting the appropriate mathematical model and applying the boundary conditions to our model.

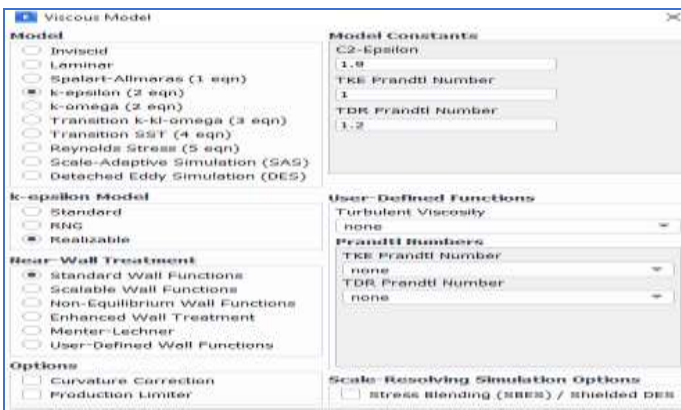

Figure 15 Viscous model

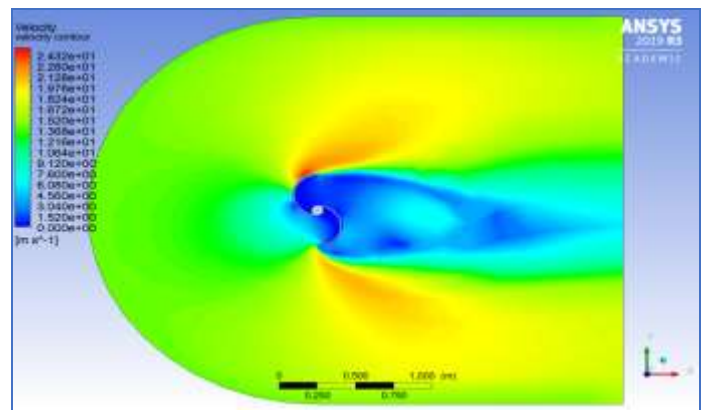

Figure 19 Velocity contour

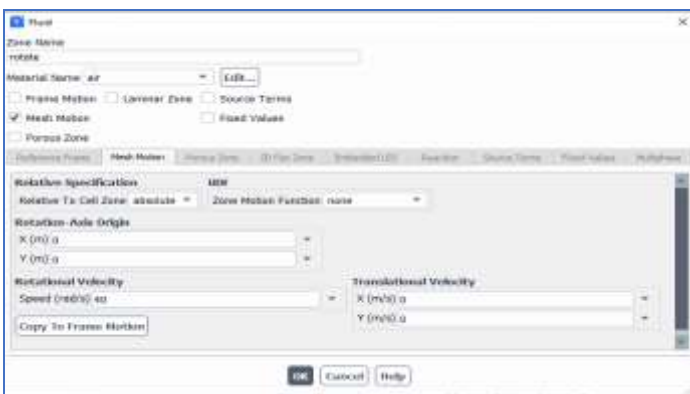

Figure 16 Boundary conditions

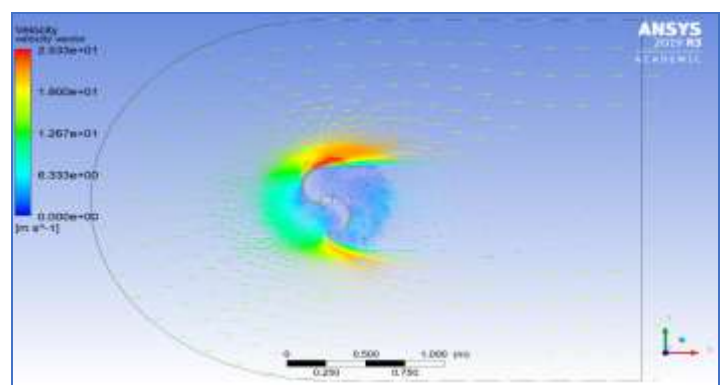

Figure 20 Velocity vector

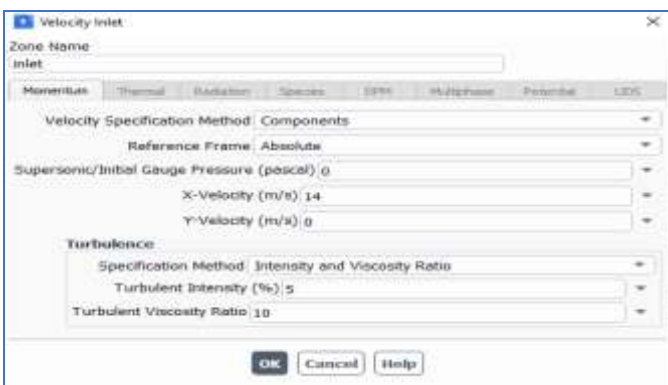

Figure 17 Boundary conditions

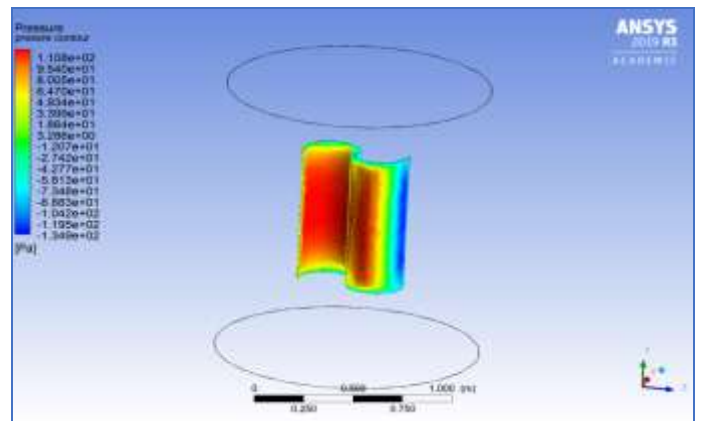

Figure 21 Pressure contour on blades

#### 4. RESULTS

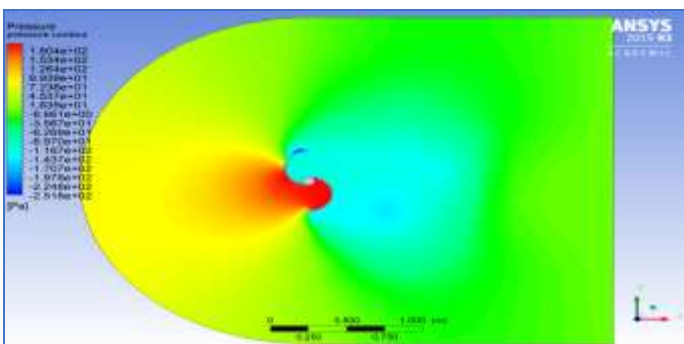

Figure 18 Pressure contour



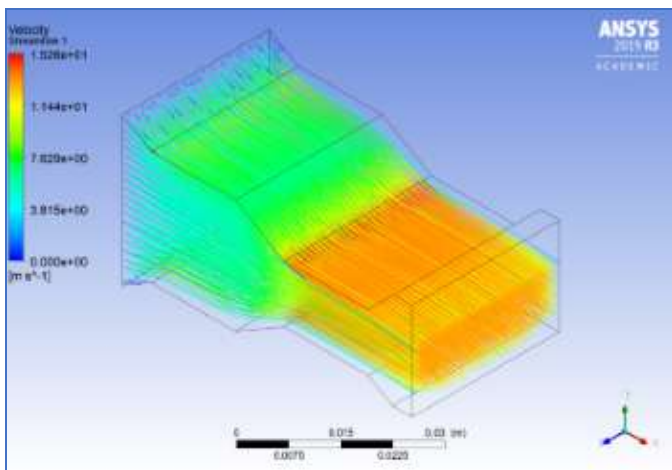

Figure 22 Velocity streamline in duct

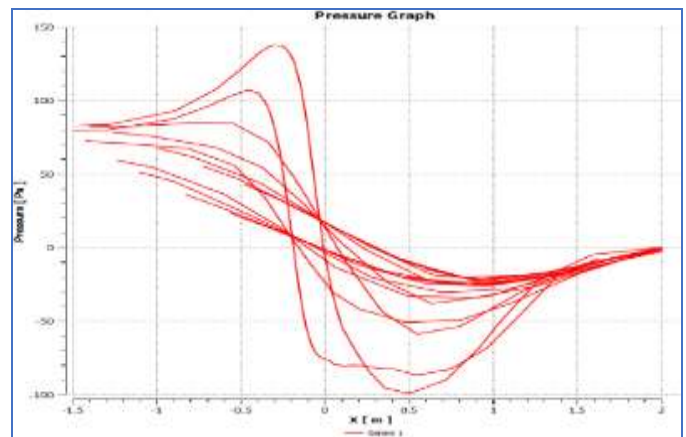

Figure 25 Pressure graph

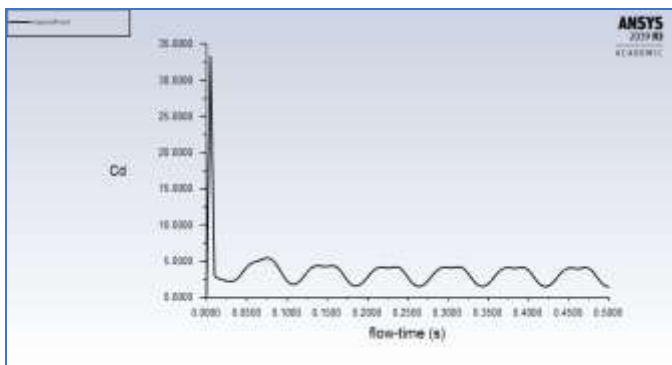

Figure 23 Drag coefficient

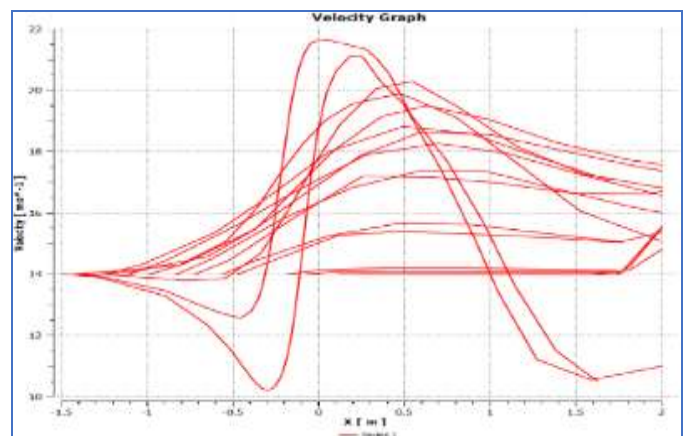

Figure 26 Velocity graph

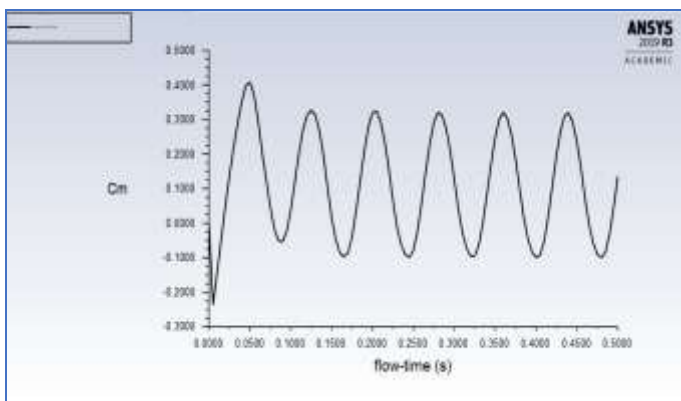

Figure 24 Moment coefficient

## 5. STATIC STRUCTURAL ANALYSIS

Structural analysis is the analysis of the effects of loads on physical structures and their components. Statistic structural shows how the effects of pressure, moment, stress, strain affect the structure externally and internally. Structures subject to this type of analysis include all that must withstand loads, such as buildings, bridges, aircraft and ships. Structural analysis employs the fields of applied mechanics, materials science and applied mathematics to compute a structure's deformations, internal forces, stresses, support reactions, accelerations, and stability. Results obtained will be verified with the structure fitness for use.

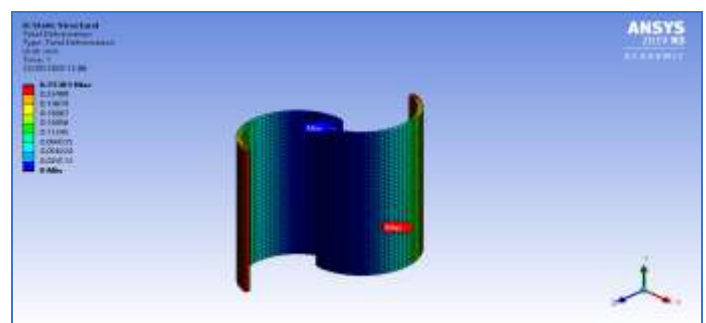

Figure 27 Total deformation

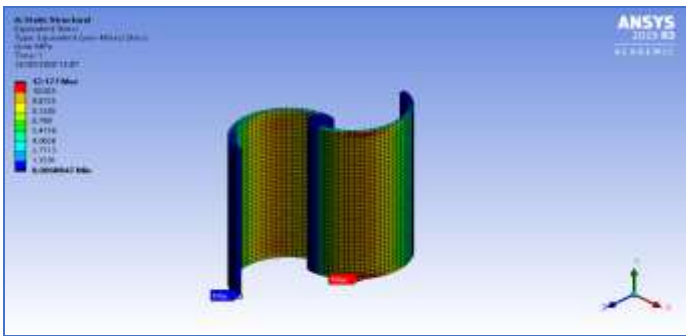

Figure 28 Equivalent (von mises) stress

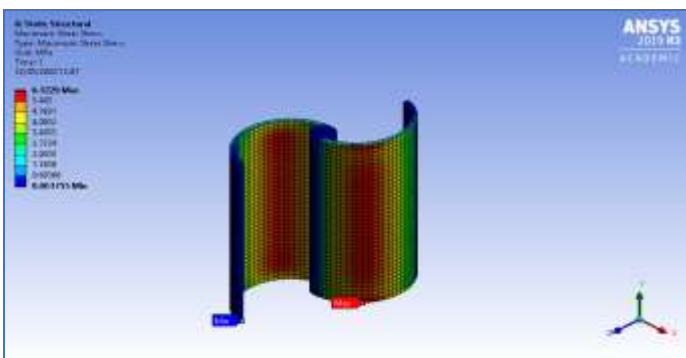

Figure 29 Maximum shear stress

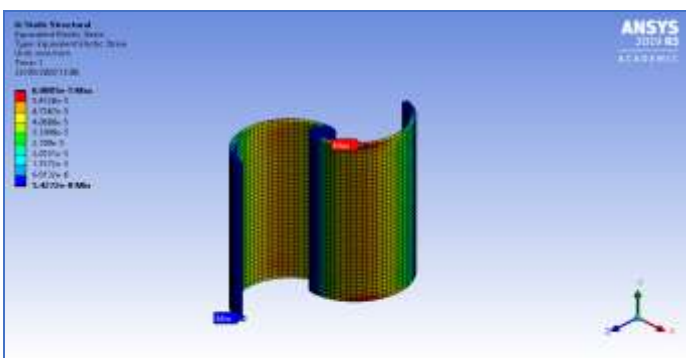

Figure 30 Equivalent elastic strain

## 5. CALCULATION

1.  $A = D \cdot H \text{ (m}^2\text{)} = (550 \cdot 400) / 10^6 = 0.22 \text{m}^2$
2.  $N = (\omega \cdot 60) / 2\pi R = (60 \cdot 40) / (2\pi \cdot 0.275) = 1389 \text{ rpm}$
4. **Tip Speed Ratio = T.S.R.**  $= (\omega R) / V = (40 \cdot 0.275) / 14 = 0.785$
5.  $P_{\text{max}} = 0.5 \cdot C_p \cdot \rho \cdot A \cdot V^3 = 0.5 \cdot (16/27) \cdot 1.1767 \cdot 0.22 \cdot (14)^3 = 210.47 \text{ watts}$
6. **Power = Torque (N.m) \* Angular velocity  $\omega$  (rad/s)**  
 $\therefore$  **Torque = (Power / Angular velocity) = 210.47/40 = 5.25 N-m**
7. **Equivalent (Von-Mises stress) = 12.177 Mpa**  
 The stress obtained is satisfactory as the equivalent stress is much lower than the yield strength of the material of the turbine blades. Hence, the turbine blade structure is acceptable.
8. **Total deformation = 0.25301 mm**

Total deformation is considerably small as compared to the total size of the wind turbine. Hence, it is also acceptable.

9. **Shear stress = 6.1229 Mpa**

## 6. CONCLUSIONS

- (1) The experiment shows that it is possible to recover energy from the exhaust air.
- (2) The duct design is optimized to create venturi effect so that exhaust air flow can interact with the wind turbine blades.
- (3) In addition to that, it will provide a protection from the outer environment to safeguard the entire system.
- (4) Due to the simplicity of design, this system is applicable to any exhaust system.
- (5) Furthermore, conventional natural winds speed varies frequently whereas fans are constant speed devices which will not affect the performance of turbine speed.
- (6) Due to this very low rotation speed fluctuations will be experienced by the turbine and hence it will increase the durability of turbine and in turn it will minimise the cost of turbine and eventually maintenance cost will be low.
- (7) Velocity at the inlet of duct was measured 5 m/s and after passing through duct, velocity obtained at the outlet of duct was 14 m/s.
- (8) Maximum power output obtained from the turbine is 210.47 watts.
- (9) The structure of Savonius wind turbine is safe as all the parameters required to obtain factor of safety is fulfilled.

## REFERENCES

- [1] "Energy recovery from exhaust air of textile industry" by mehari Weldemariam Degefa, Solomon Tesfamariam Teferi, ijrse (vol.3, no.4).
- [2] "Design and Analysis of Vertical Axis Savonius Wind Turbine" by S. Jagadish Venkata Sai, T. Venkateswara Rao
- [3] "Savonius wind turbine design and validation-a manufacturing approach" by M. Sunil Kumar, VVSH Prasad, C. Labesh Kumar, Dr. K Ashok Reddy
- [4] "Design and analysis of vertical axis wind turbine blade made of GFRP composite material using ANSYS" by M. Saravanan & Dr.K.G. Muthurajan
- [5] "Design, analysis and fabrication of Savonius vertical axis wind turbine" by Ashwin Dhote, Prof. Vaibhav Bankar
- [6] "Generation of electricity from exhausted air" by Hemanth M Hiremath, Abhishek M, Anitha D.J, Soujanya E.M, Ravindra M.P
- [7] "Design and Performance Analysis of Low Speed Vertical Axis Windmill" by L. Natrayan, T. Amalesh, Sirajuddin Syed
- [8] "Design and Analysis of Vertical Axis Savonius Wind Turbine" by S. Jagadish Venkata Sai, T. Venkateswara Rao. "Generation of electricity using exhaust from bike" by S. Vijaya Kumar, Amit Kumar Singh, Athul Sabu, Mohamed Farhan. P, (vol.4, special issue 6).



- [9] "Generation of electricity using exhaust gas" by Venkatesh.J, Karthik Kumar. r, Karthikeyan. g, Kavin. r, Keerthi raja s.v.g, (vol.8, issue 4).
- [10] "Utilization of exhaust gas of vehicle for electricity generation" by shaikh Mobin a., shaikh saif a., shaikh najim n., pathan Umar Farooq o., pathan Farhan a. (vol.4, issue 3).
- [11] "Power generation from exhaust gas of an ic engine" by impha y d., Mahammad yunus c., Ajaygan k., mustaqeem raja, Mohammed Imran, Harsha raj k. (vol.6, issue 6).
- [12] "Review on Savonius type vertical axis wind turbine" by Mamta Patil, Pankaj Kumbhar, Shubham Sutar, Gurunath Savant, Nikhil Nikam, Sushant Jadhav.
- [13] "A Review Paper on Vertical Axis Wind Turbine for Design and Performance Study to Generate Electricity on Highway" by Prof. Sunil Shukla, Dr. P. K. Sharma, Suryabhan A. Patil.
- [14] "Performance Augmentation of V- Bladed Savonius Wind Turbine" by A Vivek Anand, M Sathyanarayana Gupta, J Sahana, P Shanmuga Priya, V Hariprasad.
- [15] "An experimental study on the performance of Savonius wind turbines related with the number of blades" by Frederikus Wenehenubuna, Andy Saputra, Hadi Sutanto,
- [16] "Modified Design of Savonius Wind Turbine Blade for Performance Improvement" by M. Zemamou, A. Toumi, K. Mrigua, M. Aggour.
- [17] "Numerical Investigation of the Savonius Vertical Axis Wind Turbine and Evaluation of the Effect of the Overlap Parameter in Both Horizontal and Vertical Directions on Its Performance" by Mohammad Ebrahimpour, Rouzbeh Shafaghat, Rezvan Alamian and Mostafa Safdari Shadloo.
- [18] "Experimental Comparison Study for Savonius Wind Turbine of Two & Three Blades at Low Wind Speed" by Mohammed Hadi Ali Lecturer University of Mustansiriya.