

Energy Consumption Indicator

Mr. K.S. Gowthaman¹, Mr. M. Arunkumar², S.Hari Prasath³, K.Vijaya Kumar⁴, P.Senthil

Poonkumaran⁵, S.Venkadesh⁶

[1,2] Assistant Professors, Department of Electrical and Electronics Engineering, Government College of Engineering Thanjavur - 613 402, Tamil Nadu, India

[3,4,5,6] Final year Students, Department of Electrical and Electronics Engineering, Government College of Engineering Thanjavur - 613 402, Tamil Nadu, India

Abstract - Nowadays, peoples are unaware of the cost of energy consumed by various appliances used in household. This project aims to design a circuit which helps the consumer in taking care of his/her electrical energy consumption. It affects the consumer's bill severely. To make the consumer aware and to control the excess energy consumption, this paper introduces, "ENERGY CONSUMPTION INDICATOR". This system will intimate to the consumer about his /her previous set energy consumption value once the meter reached to that value. It will also alert the limited voltage, power factor, frequency. In this way, the consumer made aware of his/her energy consumption, Once the maximum threshold value is reached, the notification sent to the consumer by sending SMS to his /her registered mobile number. It is not only benefits to the consumer and, it also benefits to the government in the point of reducing the power consumption and subsequent reducing of unusual power usage.

Key Words: ARDUINO MEGA, RASPBERRY PI, AC COMMUNICATION BOX (PZEM004T), FAST2SMS.

1. INTRODUCTION

Today electrical energy is the basic need of human beings. It is the prime mover of the many of the electrical components. The future is based on the electricity so we need to save it, because they will not available for long days.

"ENERGY CONSUMPTION INDICATOR" mainly aims at households to bring their electricity bill down with the help of the energy consumption alert system and also alert for power factor, as well as frequency. Energy meters being deployed at homes and industries are used for reading the power, i.e. energy being consumed. Each consumer must fix a customized threshold value of unit (depends on his/her own interest or bill rate), power factor, frequency. If the value reached to the above rated threshold value, the notification sent to the consumer to his /her mobile number with the help of a (mobile application or reports are given periodically to the specified mobile number through website).

We can install this indicator in any place like home, industries and where we want to monitor the electricity. Customer can fix the threshold value of energy for their requirement.

ENERGY CONSUMPTION INDICATOR is used to continuously monitor the meter reading. Major components used in this project are ARDUINO Board, Raspberry Pi, Energy meter circuit (PZEM004T) and the load. ARDUINO and Raspberry Pi is a credit card sized minicomputer and act as a fast processor system. It is the central unit of this project and is connected energy meter circuit through various ports. The overall operation of the proposed system is discussed in the following sections.

2. LITERATURE SURVEY

Literatures [1], [2], [3], [4], [5] research work done by scholars in this domain of wind power consumption area. where they discussed about monitoring of energy reading.

Transaction of energy conversion [6] here they used to find the track of energy conversion.

For easy communication between EB officer and consumer readings [7] they used the GSM based power management with reduced cost.

For monitoring the electrical energy in home appliances [8] they used wireless sensor and actuator network. This helps the customer to monitor the unit of energy consumed.

A prepaid energy meter using mobile communication [9] they use a prepaid card communicating with energy meter, where the cost is deducted using prepaid card for unit of energy consumed by he /she, Once the prepaid card is out of balance, the load of the consumer is disconnected from the utility supply by the contactor.

3. SYSTEM ANALYSIS

The various literature studies that were done by the various people, helps us to develop a new technique for controlling and monitoring the energy consumption.

3.1. Issues in the existing system

i. No indication about power factor
i.e. power factor lagging situation. As a result of this, the slab rates are doubled and this leads to a high bill amount.

ii. Electricity usage i.e. unit is not monitored
 There is no awareness about the electricity usage in our day to day life. Only the total consumption can be calculated at mentioned only. Slab rate changes and amount of energy consumption cannot be predetermined and measured in the existing energy meters. In Tamil Nadu, the Bi-monthly consumption is determined in households.

iii. Energy consumption is not notified
 Customer cannot receive i.e unit notification regarding the usage of energy, even if the customer consumes higher units of energy, In present system, there is no notification message or alert given to the customer which is the major disadvantage of the current system. If the user is know about his/her own energy consumption value. He/she try to reduce the consumption rate by his/her. It will drastically reduce the price as well.



Fig-1 PZEM004T

3.2. Proposed System

This project is aimed to design a circuit which helps the consumer to monitor the electrical energy consumption and protect him/her from the extra charges incurred due to minor changes in slab categories (particularly in household consumption TN), since even small changes can affect the bill at a high rate. In this project, electricity usage is updated when the meter reading reached the threshold value and then sent to the ARDUINO. The energy values once taken from the energy meter are digitalized and processed with the help of a micro controller. The ARDUINO micro controller is used here ARDUINO MEGA. Daily consumption cost will be updated to the user through SMS through Raspberry Pi. The problem of overload can also be monitored with the help of ARDUINO. When the circuit is overloaded, the difference in consumption is also analyzed. This deviation from the normal value is notified to customer to prevent the excess charges.

4.1.2. ARDUINO MEGA

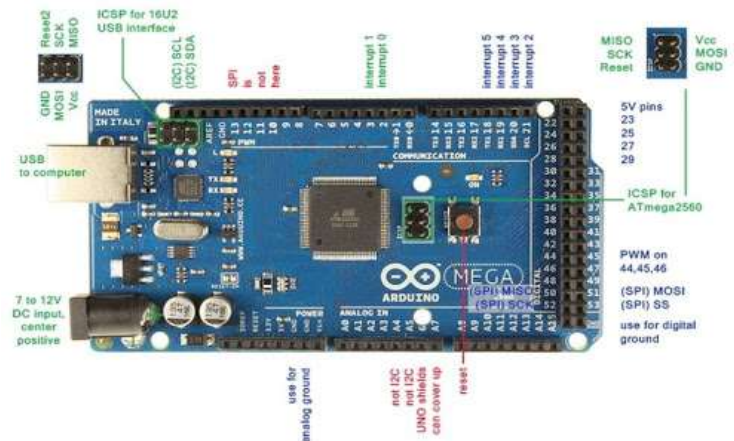

Fig-2 ARDUINO MEGA

4. SYSTEM DESCRIPTION

The pictures given bellow are describe the detailed explanation of the above proposed system.

4.1. Hardware Requirements

4.1.1. AC COMMUNICATION BOX (PZEM004T)

An electricity meter is a device that measures the amount of electric energy consumed by the residence, business, or any electrically powered device. Here we use PZEM004T which measure the electrical parameters such as voltage, current, power, energy, frequency, power factor. First it measure the voltage value and then its current transformer measure the current value further itself generate the other parameters. The measured values are transferred as digital signal to the micro controller through the TTL port provided itself

Arduino Mega 2560 is a type of microcontroller board. Which contain 54 digital input / output pins, 16 analog inputs, USB ports etc, Here which is used to run the program for getting then output of energy meter reading and send the reading to raspberry pi connected with it.

4.1.3. Raspberry Pi

The Raspberry Pi is a type of microprocessor board, We can connect with monitor, mobile phones, keyboard, TV etc, which is used to explore computing all age people in language such as Python.



Fig-3 Raspberry Pi

4.2. Software Requirements

4.2.1. ARDUINO IDE

The ARDUINO IDE is a cross-platform, software which easily extensible environment written in java which is used to upload programs in arduino board.

4.2.1. VNC Viewer

It is used to run python for operating raspberry pi. Also this helps in uploading the code to the Raspberry Pi board.

4.3. System Architecture

An ac source is given to the energy meter circuit and load is connected with the energy meter.

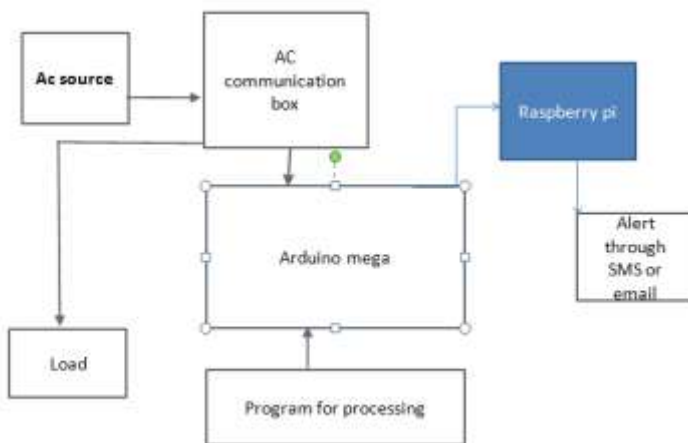

Fig-4 Architecture diagram

circuit through TTL port and the output of the arduino is connected to the raspberry pi from which the python is uploaded to sent the alert or SMS notification send to the required mobile number.

4.4. Working System

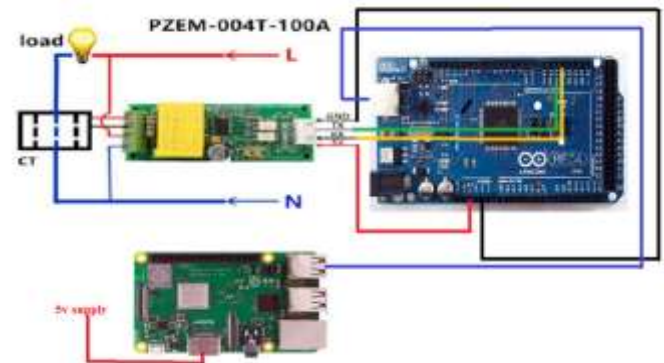

Fig-5 Working System

Load is connected to the PZEM004T through the current transformer and the load data are transferred to the Arduino board through TTL port such as voltage, current, power, energy, frequency, power factor which are continuously monitored. From the uploaded arduino program the output of the electrical parameters are monitored and transferred to the wifi connected Raspberry Pi. If the value reaches above the threshold value, notification alert or message sent to his /her mobile number with the help of a website fast2sms linked with the python program uploaded in the Raspberry Pi to the consumer.

5. Experimental Results and Discussion

The result of the above proposed system is discussed here. The text message send from the alert system to the mobile phone is given below this message and is received periodically.

Values displayed in the Raspberry Pi is mentioned here.

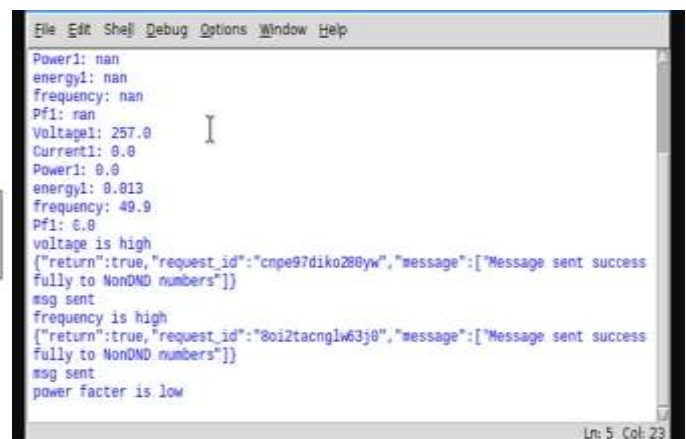

Fig-6 Output value from Raspberry Pi

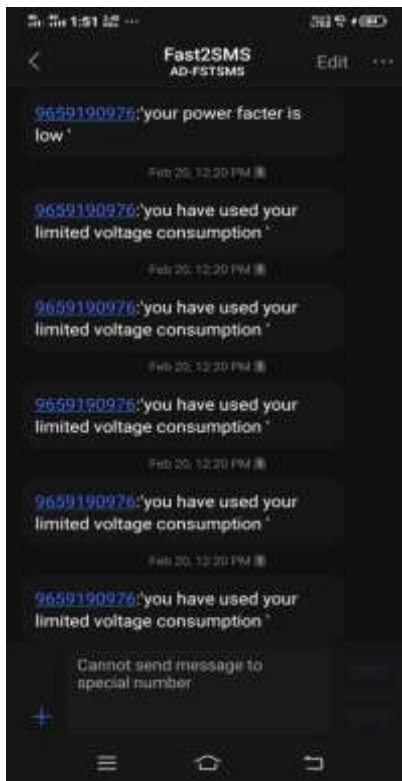

Fig-7 Screenshot showing the SMS

6. CONCLUSIONS

Thus, the Energy Consumption Indicator is used to alert the customer or consumer regarding his / her consumption of electricity. This helps him / her make awareness in their consumption. Here a module consisting of the ARDUINO board, Raspberry Pi and PZEM004T to make the electricity consumption smarter.

REFERENCES

- [1] Changliang Xia, Member, IEEE, Xin Gu, Tingna Shi, and Yan Yan, "Neutral-Point Potential Balancing of Three-Level Inverters in Direct-Driven Wind Energy Conversion System" IEEE TRANSACTIONS ON ENERGY CONVERSION, VOL. 26, NO. 1, MARCH 2011.
- [2] Vijay Chand Ganti, Bhim Singh, Fellow, IEEE, Shiv Kumar Aggarwal, and Tara Chandra Kandpal, "DFIG-Based Wind Power Conversion With Grid Power Leveling for Reduced Gusts" IEEE TRANSACTIONS ON SUSTAINABLE ENERGY, VOL. 3, NO. 1, JANUARY 2012.
- [3] Jiabing Hu, Member, IEEE, Hailiang Xu, Student Member, IEEE, and Yikang He, Senior Member, IEEE Coordinated Control of DFIG's RSC and GSC.

- [4] Under Generalized Unbalanced and Distorted Grid Voltage Conditions", IEEE TRANSACTIONS ON INDUSTRIAL ELECTRONICS, VOL. 60, NO. 7, JULY 2013.
- [5] Yipeng Song, Student Member, IEEE, and Heng Nian, Member, IEEE "Modularized Control Strategy and Performance Analysis of DFIG System Under Unbalanced and Harmonic Grid Voltage" IEEE TRANSACTIONS ON POWER ELECTRONICS, VOL. 30, NO. 9, SEPTEMBER 2015.
- [6] Muhamad Zahim Sujod, Member, IEEE, Istvan Erlich, Senior Member, IEEE, and Stephan IEEE TRANSACTIONS ON ENERGY CONVERSION, VOL. 28, NO. 3, SEPTEMBER 2013.
- [7] B.S.Sathish Dr.P.Thirusakthimurugan and R.Narmadha "INTERNATIONAL JOURNAL OF ADVANCED RESEARCH IN COMPUTER ENGINEERING & TECHNOLOGY (IJARCET)" An Advanced Power Management Using GSM Module Volume 3 Issue 4, April 2014 1101 ISSN: 2278 - 1323.
- [8] Edwin Chobot, Daniel Newby "INTERNATIONAL JOURNAL OF EMBEDDED SYSTEMS AND APPLICATIONS" Design and Implementation of a Wireless Sensor and Actuator Network for Energy Measurement and Control at Home vol. 3, no. 1, March 2013.
- [9] Amit Jain, Mohnish Bagree "INTERNATIONAL JOURNAL OF ENGINEERING, SCIENCE AND TECHNOLOGY" A prepaid meter using mobile communication Vol. 3, No. 3, 2011, pp. 160-166.