

Power Line Communication (PLC) using PIC Micro-controller

Mr.Rushikesh D. Maskare¹, Mr.Dhirajkumar S. Dhawane², Mr.Ashish G. Dighade³, Ms. Neha S. Talware⁴, Ms.Pallvi R. Patil⁵, Prof. Kirti B. Nagne⁶

^{1,2,3,4,5}UG Students, Electrical Engineering, DES'sCOET, Dhamangaon Rly, Maharashtra, (India)

⁶Assistant Professor, Electrical Engineering, DES'sCOET, Dhamangaon Rly, Maharashtra, (India)

Abstract- A method of power line communication (PLC) appropriate for the reading of power meters is presented. There is design, manufacture and testing of a PLC transmitter, receiver and interfacing circuit. Experimental findings of digital data transmitted over power lines of 220V/50 Hz are presented. The system fulfills the necessary specifications of stability, reliability, and precision. The device was tested and the transmitted signal was found to have suffered from very low noise and distortion levels. A Power line communication (PLC) system suitable for power meter reading is presented. A PLC transmitter, receiver and interfacing circuit are designed, fabricated and tested.

Key Words: Power line communication, PLC, PIC, utility services, electrical distributed network.

1. INTRODUCTION

Power line communication (PLC) is a technology that employs the infrastructure of electrical power distributed system as communication medium. PLC technology could provide the consumer with a spectrum of services such as internet, home entertainment, home automation, and enable the electricity supply authority to efficiently manage their distribution networks in a competitive manner. This technique has immediate attraction for meter communication system, since every consumer is connected to the communication network and that network is owned and controlled by the electricity supply authority. In a meter reading communication system high power signals are transmitted through the network, which are then received by all connected meters.

A recent survey shows that one third of new broadband customers will choose power line communication by 2012. PLC technology could also let the power distribution companies open lucrative revenue streams by bundling electricity supply with broadband telecommunication access providing high speed and reliable communication traffic including Internet access. This system has been extensively implemented in Europe and especially in France. PLC systems can also be used to transfer data inside buildings using power lines discounting the cost of insulating communication cables.

In this paper we present a simple hardware implementation for a PLC system using a Peripheral Interface Controller (PIC) microcontroller which provides data generation and interfacing. The system is suitable for data communications within a local power network area, such as remote automatic meter reading, fire and security alarm control, etc. The system is built using on-off-keying (OOK) modulation to reduce complexity.

The PLC system is connected to power lines using proper interfacing circuits which are used to provide electrical isolation and impedance adaptation between the PIC and the power line network. PLC technology offers many advantages over other wire line and wireless communication technology that makes PLC efficient and economic to use in some applications. First; PLC uses the existing infrastructure of power line networks which means a great savings in wiring. Second; PLC is more secure than wireless, and telephone line communication. Transmitted data within any house, company etc, can not be hacked by anyone out of the sub-network.

This means that the system can be implemented using the available off-the-shelf components and hence a great reduction in the cost of the overall system. The system was tested during many hours of continuous operation, and it was found that the transmitted signal suffered from small distortion levels. PLC technology offers many advantages over other wire line and wireless communication technology that makes PLC efficient and economic to use in some applications. First; PLC uses the existing infrastructure of power line networks which means a great savings in wiring. Second; PLC is more secure than wireless, and telephone line communication. Transmitted data within any house, company etc, can not be hacked by anyone out of the sub-network. The PLC system is connected to power lines using proper interfacing circuits which are used to provide electrical isolation and impedance adaptation between the PIC and the power line network. This means that the system can be implemented using the available off-the-shelf components and hence a great reduction in the cost of the overall system.

The system was tested during many hours of continuous operation, and it was found that the transmitted signal suffered from small distortion levels. This technique has immediate attraction for meter

communication system, since every consumer is connected to the communication network and that network is owned and controlled by the electricity supply authority.

1.1 PLC SYSTEM

A PLC transmitter should be designed properly to enhance the signal against a hostile environment. The transmission line medium is considered as a very harmful environment against digital data. This is because power line transmission environment may contain stray signals in the form of pulses that could be noisy at the receiver side. These pulses may interfere with the transmitted signals and create an unwanted distortion that disturbs the operation of the system. Therefore, base-band transmission of data is inefficient and hence one of the digital modulation techniques needs to be used to obtain immune data form and to guarantee safe transmission process. A PLC receiver is connected to the power-line network via an interfacing circuit. A preamplifier is used to compensate for the losses in the power lines. The amplified signal is demodulated to recover the original data, and then passed to a data sink.

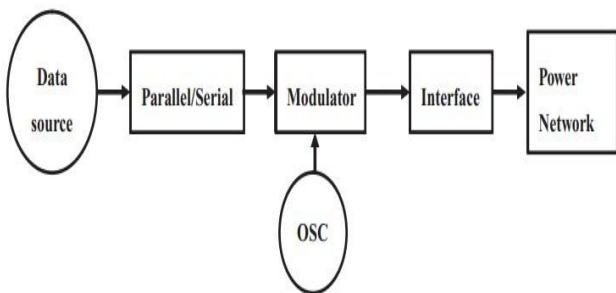

Fig.1: Block Diagram of PLC Transmitter System

Figure 1. Shows the bock diagram of the PLC Transmitter system. A basic PLC transmitter consists of five main sub-stages: a data source, a serial to parallel converter, a carrier frequency oscillator, a digital modulator and an interfacing circuit. Figure 2 Shows the bolck diagram of the PLC Reciever system.

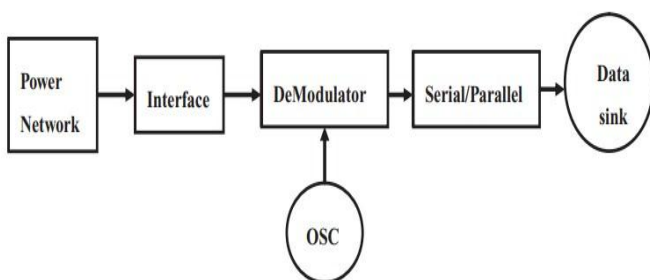

Fig.2: Block Diagram of PLC Reciever System

The transmitter function is to modulate the data signal using one of the digital modulation techniques and then to load it to the power-line network. OOK modulation is usually used because it provides a reliable and yet a simple system. OOK modulation is a special case of ASK (Amplitude Shift Keying) modulation, where no carrier is present during the transmission of a zero.

2. METHODOLOGY

2.1 PLC System Design Using PIC

We use a microcontroller in this article to provide date generation and synchronization. The input data to the PLC transmitter is parallel data which may come from PC, a DIP switches, etc. A PIC microcontroller is used to read parallel input data and then convert it into serial data ready for digital modulation. PIC is also used to enable transmission of data after a certain delay to ensure that the turns on/off spikes are removed. A pin diagram of a PIC 16F876 is shown in Figure 3.

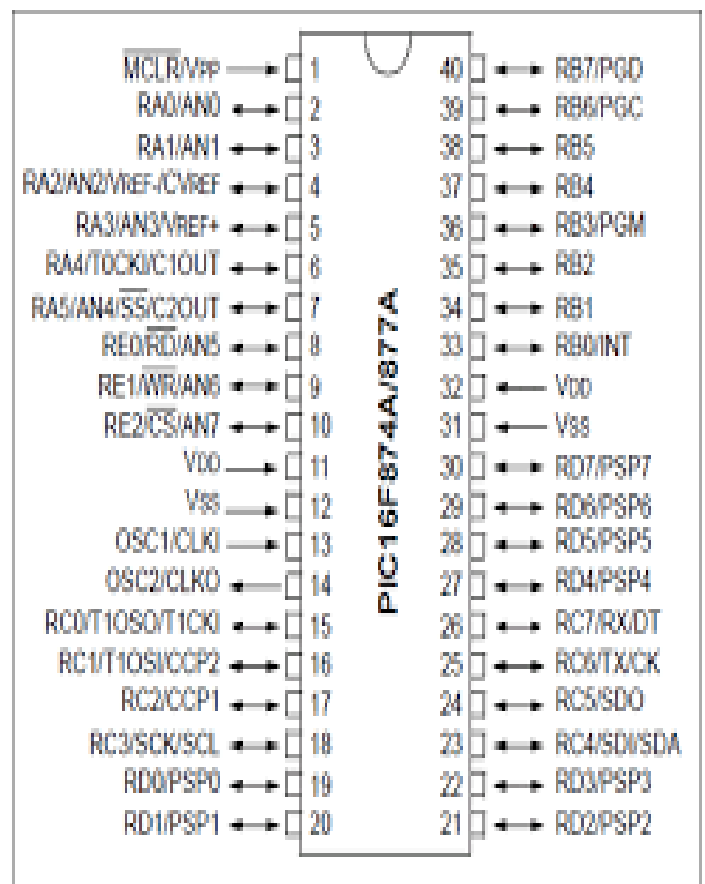

Fig.3: Pin Diagram of a PIC 16F876

2.2 PLC Transmitter

The PLC controller consists of the PIC 16F876 which is used as a data source and data synchronizer, an OOK modulator, a power amplifier and an interfacing

circuit. A level converter (an operational amplifier which works as a simple comparator) is used to convert data levels between the PIC and the OOK modulator. Figure 4 shows a schematic of the proposed transmitter circuit.

The modulated signal is loaded to the power-line by an interfacing circuit which consists of an LC resonant circuit after power amplification which provides the current level needed to drive the interfacing circuit. The power amplifier was designed using the C3039 power transistor. The C3039 power transistor is usually used for high voltage, high speed applications, especially in inductive circuits. The interfacing circuit isolates the 220 V/50 Hz from the low voltage environment of the PLC transmitter. The interfacing circuit is also used to suppress the high voltage spike generated by switching.

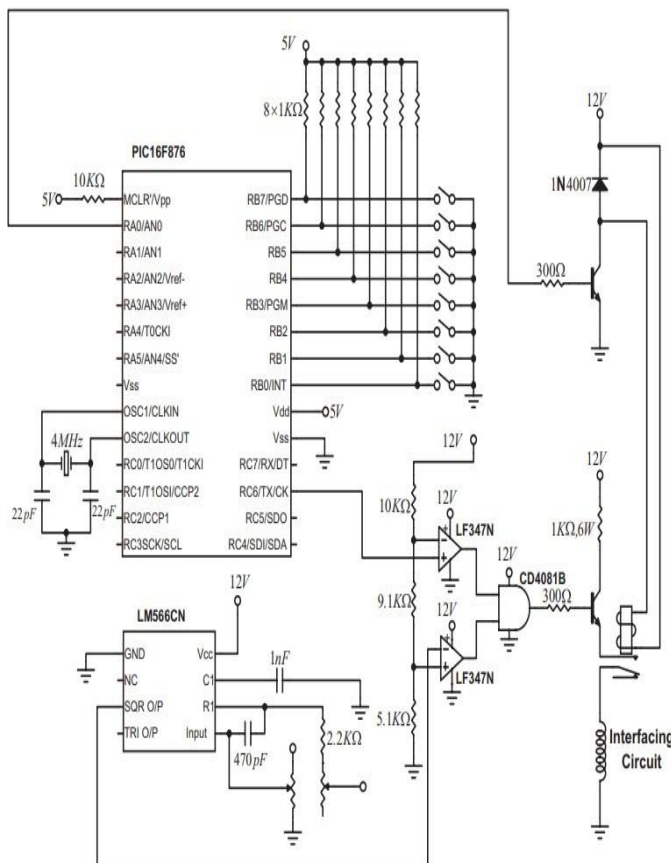

Fig.4: PLC transmitter schematic

To minimize the effect of the distortion problem, critical parameter selections have been used based on working experience and best output results. The selected carrier frequency (f_c) has to be constant, stable and much higher than the Data Baud Rate. Therefore, an oscillator was built using LM566CN voltage controlled oscillator to produce a rectangular waveform with frequency of 140 KHz which is much greater than the used data baud

rate(500 bit/sec). A rectangular waveform was selected because it achieves better distortion performance.

2.3 PLC Receiver

In the proposed PLC receiver, the received signal is first amplified using a preamplifier. Then the amplified signal is entered to the OOK demodulator, which recovers the original data. The received data is then passed to the microcontroller which converts serial data into parallel data. An interfacing circuit similar to the interfacing circuit used the transmitter is used to isolate the receiver from the 220 V/50 Hz environment. Figure 7 shows a block diagram of the proposed PLC receiver and Figure 8 shows a schematic diagram of the receiver circuit.

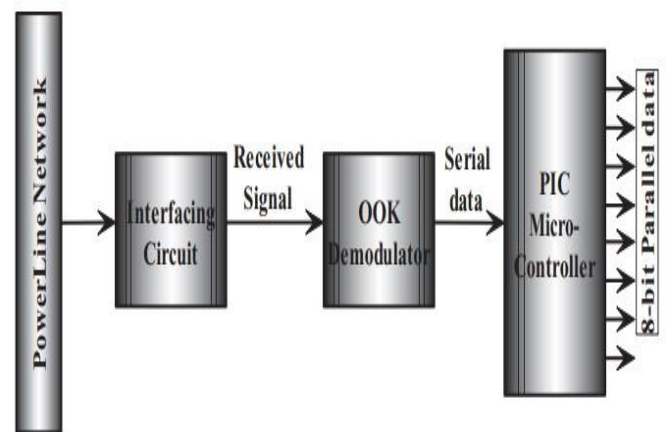

Fig.5: A block diagram of the proposed PLC receiver.

The OOK modulator/demodulator circuits were designed using a basic logical AND gates preceded by level converters used to interface TTL to CMOS of the PIC and the OOK modulator. An operational amplified that operates as a comparator was used as a level converter. The comparator converts data levels to other levels where logic HIGH is greater than 8 V and logic LOW is less than 2 V. The carrier signal used in OOK modulation was obtained using an LM566CN voltage controlled oscillator

3. IMPLEMENTATION

The interfacing circuit was tested by measuring the leakage voltage of the 220 V/50 Hz signal that can be passed by this circuit. It was found that the maximum leakage signal amplitude was 36 mV which does not cause any problem to the electronic components of the transceiver. The microcontroller was programmed to read parallel input data on PORT B (from RB0 RB7), then converts it into serial. The PIC then transmits the data serially via the RS232, (RC6/TX/CK) transmitting pin. The flowchart of the program used in PIC16F876 is shown in Figure 6.

3.1 Software Design

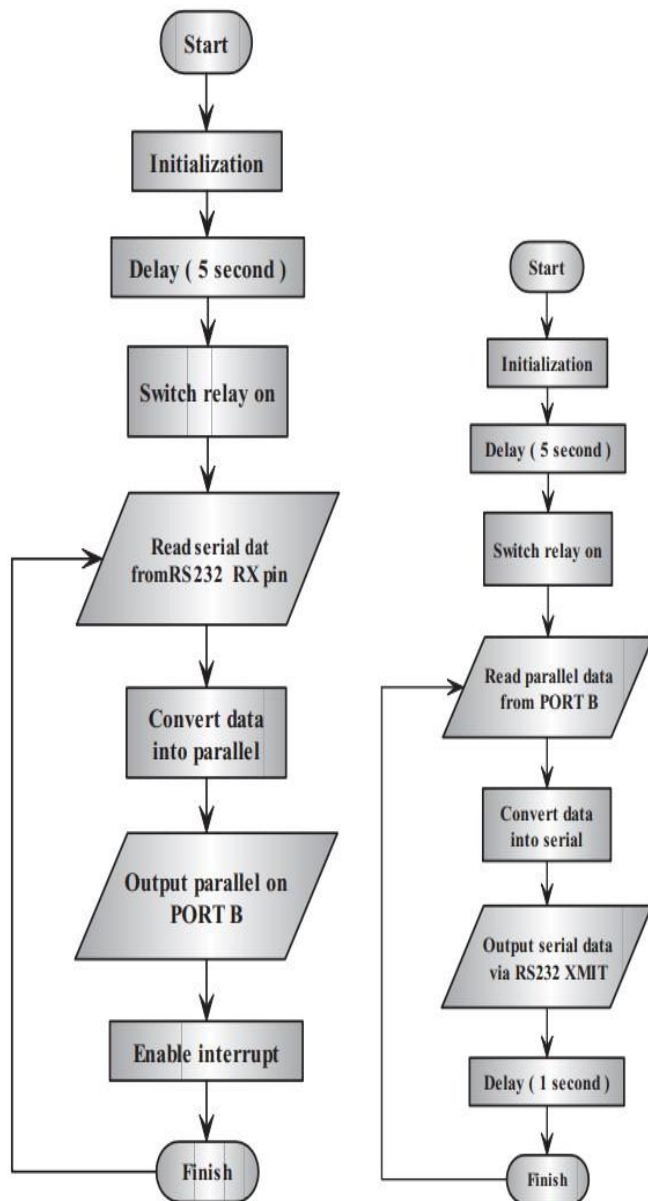

Fig.6: Flow chart used to program the PIC-16F876.

The microcontroller was programmed to enable transmission of data after a time delay to ensure that the spikes generated from switching the circuit on are removed. The interfacing circuit was tested using three different types of signals; sinusoidal, triangle and rectangular signals to assess the attenuation, distortion and noise performance of the circuit. The transmitted signal was monitored during transmission in three points; at the transmitter terminal before entering the interfacing circuit, on the power-line, and at the receiver stage. It was found that sinusoidal signal suffers from high attenuation levels and hence a rectangular waveform needs to be used as a carrier signal.

3.2 Advantages

- (i) PLC's are easily programmed and have an easily understood programming system.
- (ii) It is capable of handling of very large complicated operations and faults.

4. CONCLUSIONS

We have designed a simple and reliable PLC system. The system achieves the required demands of stability, reliability, and accuracy. The system was tested during many hours of continuous operation, and it was found that the transmitted signal suffered from very low levels of noise and distortion. The system can be implemented using off the shelf components and can be used for low data rate applications such as meter reading and remote control applications.

ACKNOWLEDGEMENT

We take this opportunity to express our gratitude and indebtedness to our guide and H.o.D. prof. K. B. Nagne, Electrical (E & P) Department, who is a constant source of guidance and inspiration in preparing this work.

We express our sincere gratitude towards Assistant Professor whose constant help and encouragement helped us to complete our project report. We are grateful to Dr. L. P. Dhamande, Principal for this encouragement and support.

REFERENCES

- [1] Duval G. Application of power line carrier at Electricite de France, Proc. 1997 International Symp. On Power Line Comms. and its Applications, pp. 76-80.
- [2] Dostert K. Telecommunication over the power Distribution Grid Possibilities and Limitations, Proc. 1997 Internet. Symp. on Power Line Comms. and its Applications, pp. 1-9.
- [3] Gardner N. An Introduction to Programming the Microchip PIC in CCS C, 2002.
- [4] Karris S. T. Electronic Devices and amplifier Circuits. Orchard Publications, 2005.
- [5] Metcalfe B. Cheap, reliable, powerful net connections may be as close as an electric socket. Info World, February 10, 1997, 44.
- [6] Waldec T., Zimmermann M. and Dostert K. Konzepte fur Powerline Kommunikation system. Furkschau 1 (1998), 40-43.

- [7] Winder S. Analog and Digital Filter Design, 2nd edition, Butterworth-Heinemann, 2002.
- [8] http://en.wikipedia.org/wiki/Electromagnetic_interference.
- [9] http://en.wikipedia.org/wiki/On-off_keying.