

A review On-Automatic Excitation of Synchronous Motor using Single Phase Full Wave Controlled Rectifier

Ms. Ramadevi Rudra¹, Sudhir Bhuvad², Digambar Humbare³, Sonali More⁴, Poojan Tisulkar⁵

¹Assistant professor, Department of Electrical Engineering, VPM's Maharshi Parshuram College of Engineering, India

^{2,3,4,5}Students, VPM's Maharshi Parshuram College of Engineering, India

Abstract - In this paper we have done overall study of the existing excitation system in used till now. Normally excitation of the synchronous machine is done manually. The main objective of this excitation is to maintain the constant voltage drop up to certain level of the load current which is independent of the motor speed and the load. It also helps to improve the overall effectiveness of the synchronous motor.

Key Words: Single phase fully controlled rectifier, Synchronous machine.

1. INTRODUCTION

Excitation system is used to excite the field winding of synchronous machine and which help to control the field current reactive power flow of the system and field voltage. There are three types of excitation system namely DC excitation system, AC excitation and static excitation system. In the DC excitation system DC current is provide to the field winding through brushes and slip ring. In separately exciter, the exciter current is supply by the pilot exciter which is a permanent magnet generator. AC excitation is used in alternator as sources of excitation power. In this excitation, the AC output is controlled by the diode rectifier which produced direct current which is need for exciting generator field winding. As compare to the DC excitation there is no use of slip ring and brushes. The dc supply is given directly to the generator field.

The components of static excitation systems are stationary. In static system current is directly provided to synchronous generator field windings. In excitation systems mathematical models are used for controlling the parameters. The parameters of these model are depends on its gain and phase characteristics. Excitation must be controlled and should be maintain during the operating mode. A phase controlled bridge rectifier is used to obtained necessary field DC voltage supply.

2. CLASSIFICATION OF EXCITATION SYSTEM

Jerkovic, Vedrana, Spolijaric have introduced different Excitation Systems Models of Synchronous Generator [1].Excitation can be classified based on the construction, excitation of energy source. Excitation system basically consists of automatic voltage regulator (AVR), measuring elements, exciter and power system stabilizer (Fig.1). Exciter

is used to deliver electrical power for the field winding of synchronous generator. AVR is used to control the Exciter, which is very useful during steady state operation. To eliminate the sudden disturbances, power system stabilizer is used. The power system stabilizer produces an additional signal into control loop and compensates voltage oscillations. Measuring elements are used to obtain excitation system input values. Limitation and protection unit contains more number of circuits which ensure that certain physical values are limited, such as generator armature voltage, excitation current, etc. The methods used for regulation of synchronous generator excitation are linear regulation for steady state and nonlinear regulation for transient state of synchronous motor.

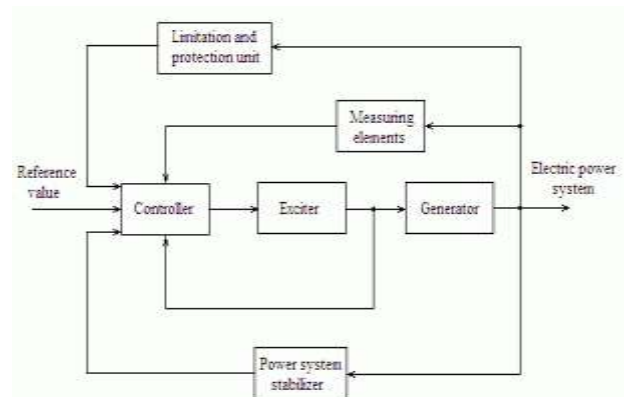

Fig-1: Excitation system of synchronous generator

3. DIFFERENT METHODS FOR EXCITING SYNCHRONOUS GENERATOR

3.1 Digital Excitation Regulator

“The synchronous generator digital excitation regulator,” presented by Ma Linlin, Wang Bing who introduced the digital excitation used in small and medium generator [2]. The digital excitation regulator system consists of exciting power unit and exciting regulator. The fig 2 shows the structure representation of this system.

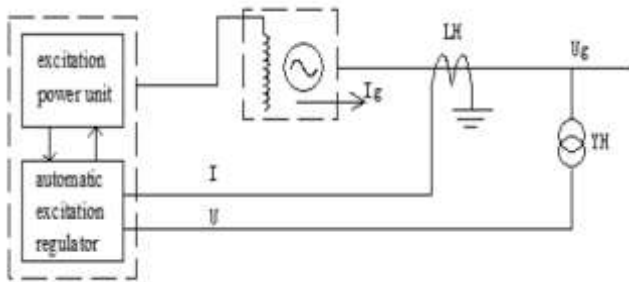

Fig -2: The structure scheme of the dynamo excitation control system

The direct current excitation system can be improved by using silicon controlled rectifier. For controlling the excitation of generator, the silicon controlled rectifier must be triggered and excitation current depends on the angle (α) of the silicon controlled rectifier. The silicon controlled rectifier is controlled by using automatic excitation regulator. In this a single phase or three phase bridge rectifier is used for the requirement of dc field voltage. The output voltage is adjusted by controlling firing angle of thyristors.

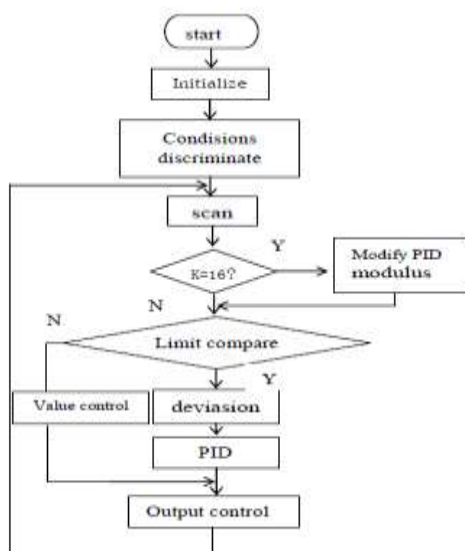

Fig-3: Flow Chart of Digital excitation System

The excitation regulator is designed with its all functions. Fig.2 is the flow chart of digital excitation regulator. This method helps to display online values of dynamo exit voltage, current and power factor. And also all the controlling parameter of the PID can be change online. This makes the system user friendly by just making some changes in the software without disturbing the hardware. It also helps to lower the cost, wide range of flexibility, high dependability and easy to repair and hence can be used in small and medium sized power plants.

3.2 Digital Excitation System by using microprocessor and controller

Godhwani, M. J. Basler presents a digital control system used on brushless excited synchronous generator [3].The digital

excitation systems having many advantages and its controlling capability and is more suitable than analog excitation system. The digital excitation system are based on microprocessor and microcontroller. Linear controllers such as P, PI, and PID are used. Automatic voltage regulator is used to maintain constant voltage. The digital excitation system is microprocessor based, that regulates various output quantities of a brushless, ac synchronous generator. The generator terminal voltage sensed by the digital excitation control system and provides it to the microprocessor via analog to digital converter. The microprocessor compares sensed voltage to a reference input. The digital excitation control system uses an eight bit microcontroller chip and PID controller. In this direct design of PID control method is used. The design is based on the two assumptions, the generator and exciter can be represented in first order models and the controller is digital. The digital control method system gives good result for machine ranging from 10Kw to 50MW.It is simple in design.

3.3 Thyristors type automatic excitation control

Vladimir A. Shikhin, Anna V. shikhina have introduced the automatic excitation controller by using thyristors [4]. This also introduced an approach for Region of Required Quality for synchronous generators for controlling systems, analysis and tuning. With accurate tuning, will help to eliminates the chances of accidents and fault in power supply. Also it helps to stable the characteristics of generating power. The Automatic Excitation Controller (RAEC) (Fig.4) contains six control channels. It is obvious that the behaviour of transferring phenomena depends on particular tunings of control channels and their composition.

The algorithm and numerical procedure is used for the designing a rapid automatic thyristors type excitation controller.

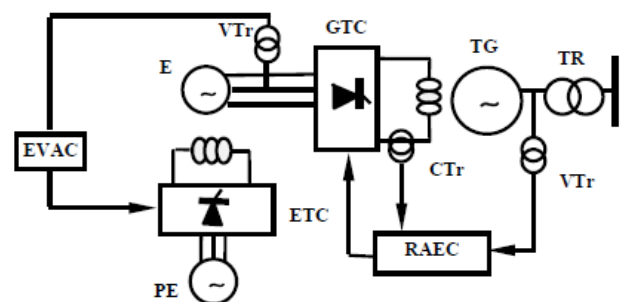

Fig-4.Block-diagram of power unit and Thyristor type Excitation Controller (RAEC)

3.4 Digital excitation done using pulse width modulation technique

Digital control systems is indirectly used to control the excitation of synchronous generator. When the voltage of the generator rises above certain percent, the voltage control algorithm already defined gets started by an interrupt

generator for synchronizing with the generator measuring voltage. After the completion of analog to digital conversion, the control of excitation current of excitation generator takes place. The excitation control is done by controlling the firing pulses of the transistor. The firing of the transistor is done by pulse width modulation. The pulse width modulation consists two timers, first one is defines a modulator frequency and second is the transistor conduction period Romina Erceg, Gorislav Erceg, Sejid Tesnjak have used this type of digital excitation system for small brushless synchronous generator [5].

3.5 Static Excitation System

R. C. Shaefer has introduces this static excitation system [6] which consists of the power controlling devices such as thyristors, power transformers and automatic voltage regulator. Basically the operation of static exciter similar like a simple automatic voltage regulator. When the excitation system senses a high generator voltage, field current decreases; when a low generator voltage is sensed, field current increases. The static excitation system includes control electronics, the power rectifier bridge and the power potential transformer. These components provide accurate field control to maintain generator output voltage The figure below explains the basic working of this static excitation(Fig.5).

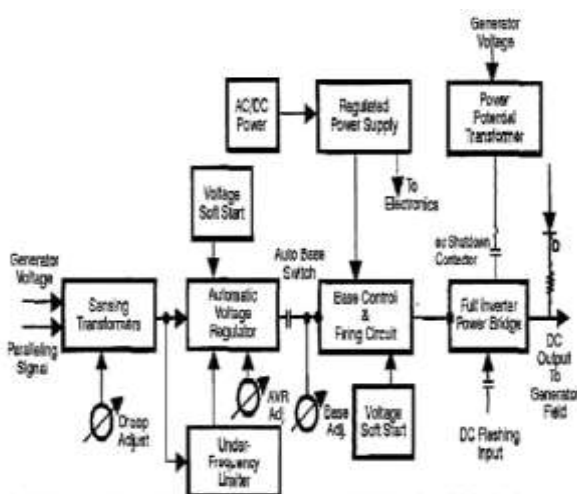

Fig-5. Block Diagram of static excitation System

3.6 PID Controller Tuning Method

PID controlling technique can also be used for excitation of the synchronous machine. D. M. Sajnekar, S. B. Deshpande, R. M. Moharil[7] have introduces this PID controller tuning method, which can be used in excitation system[8]. In this the main objective of excitation control system is to maintain terminal voltage of synchronous generator. For controlling excitation AVR is used. In addition with automatic voltage regulator, PID controller is provided in the forward path. The method used for the tuning PID controllers are either pole placement or zero cancellation method. Modelling of AVR is

needed in both the methods. PID controller can also be tuned with the help of GUI

3.7 Excitation using modelled Automatic Voltage regulator

C. S. Hoong developed an Automatic voltage regulator for synchronous generator [8] which is high efficient and reliable AVR for renewable energy application is designed. EMI filters, half wave controlled rectifier and noise suppressor are used for step downing and protecting thyristors. To control excitation current and variable speed power electronic controller is being also developed which can be used to produce self-excitation for synchronous generator. The AVR use in this can be designed with low cost circuit and consumes less power.

3.8 Comparative study for different excitation system

Shewit Tsegaye, Kinde A. Fante have discussed different excitation system [9]. There are different components which are in used for excitation like AVR, measuring elements, exciters, power system stabilizer. There are basic three types of excitation system DC excitation, AC excitation and static excitation. The excitation system is used to improve the dynamic performance. The power stabilizer uses to control the excitation system and also improve the dynamic of the power system. In this system, the under excitation limiter is used for a generator protection from dropping to the limit where the generator stability is lost. The over excitation limiters is used to prevent the generator from overheating due to more excitation. In this there are two types of delay such as fixed time and inverse time delay to produce the additional signal into closed loop (frequency 0.1 to 0.3). Discussion is done on linear regulation made by PID controller and nonlinear to achieve stability during transition state. Linear regulation is good stationary part. The nonlinear is implemented in form of fuzzy control. There is complex than the linear regulation but it increased the excitation system.

3.9 Integrated AC and DC Excitation

Jiadan Wei, Qingqing Zheng, Yiwei Yang Introduced AC and DC excitation method [10]. AC and DC excitation uses two windings. Three phase AC excitation method is used to initial start the process. The three phase winding connected in series with DC excitation winding by a switch. The frequency of the stator and rotor exciter of the main generator increases gradually. The output torque under AC excitation equal to the machine excited by DC excitation. At the switch point the dual inverter structure can be used. In brushless synchronous machine, open winding is used with dual power inverter and twelve IGBTs is used. The AC excitation are placed by three phase bridge formed of IGBTs. The two inverters are used INT1 and INT2, this two inverter are adopted by integrated AC and DC excitation. The each inverter has eight vector voltages. It is useful for machine cranking.

The author has focused on AC and DC excitation methods and double inverter is used for supplying the integrated AC and DC excitation power.

3.10 Hybrid Excitation Using PWM Rectifier

N. Patin introduces control of a DC generator based on a Hybrid Excitation Synchronous Machine using PWM rectifier [11]. In this method PWM rectifier is used (Fig 6). By using PWM rectifier the copper losses becomes less. The PWM behaves same likes a booster. This is a low cost control, possible using simple diode rectifier. It is also used in aircraft. The PWM provide more efficient control of the system.

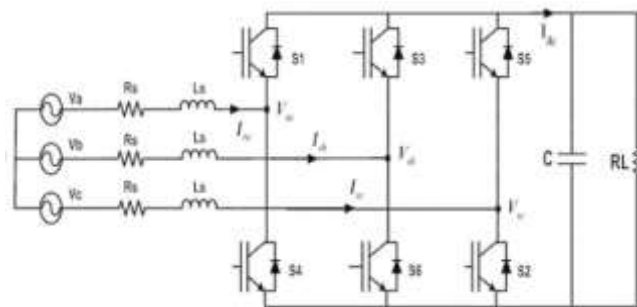

Fig-6. PWM Rectifier

The PWM rectifier is used to control in order to obtain minimum constant losses in the machine

3.11 Supplemental control

The stabilizer is a power system device is designed generator motor oscillators and controlled by the supplementary control stabilizer .The stabilizer produced the electrical torque and opposed to the change of rotor speed .The speed based stabilizer result in best modelling of the generator excitation. Power based stabilizer are used to measure the electrical and mechanical power signal speed side thyristors or Diode Bridge. The power stabilizer is used to produce the additional signal into closed loop (frequency 0.1 to 0.3).K.Kim, M.J.Basler and A.Godhwani[12] have discusses on linear regulation made by PID controller and nonlinear to achieve stability during transition state. Linear regulation is good stationary part. The nonlinear is implemented in form of fuzzy control. There is complex than the linear regulation but it increased the excitation system.

3.12 Automatic voltage Regulator

Matthew E.Obob, Jafaru Braimah introduced the automatic voltage regulator[13], it is used for a big rating of motor. The output of the generator, the field excitation is controlled by AVR. The AVR maintain the constant voltage. In this method, using AVR instead of SCR because of good performance or improve effectiveness of generator. This system becomes more reliable than previous methods. Automatic Voltage regulator provides constant output at a reasonable price. this is design for a 10 alternators field control (Table no.1)

Table no. 1

Input voltage	Output voltage	Voltage differenc	Field voltage(I	Field current(I
190	230	-40	87V	80.0mA
200	230	-30	75V	65.0mA
205	230	-25	70V	57.5mA
210	230	-20	65V	50.0mA
215	230	-15	60V	42.5mA
220	230	-10	55V	35.0mA
225	230	-5	50V	27.5mA
230	230	0	45V	20.0mA
235	230	+5	40V	12.5mA
240	230	+10	35V	05.0mA

4. CONCLUSION

Based on the present literature review, the author explained various excitation systems. Excitation system for synchronous machine is important to deliver the field current and used for protection purpose. In the excitation system some parameters are used such as AVR, Bridge rectifier and power transformer, linear controller. In modern digital technique based on the microcontroller and microprocessor and control by the PI, PID controller. Power stabilizer uses to control the excitation system and also improve the dynamic of the power system. In AC excitation, the output controlled by diode rectifier while in DC excitation the current provide to the slip ring through the rotor. The silicon controlled rectifier is controlled by using automatic excitation regulator. The excitation is needed to be done in order to improve the overall effectiveness of the synchronous motor.

REFERENCES

- [1] Jerkovic, Vedrana, Spolijaric, "Excitation System Models of Synchronous Generator."
- [2] Ma Linlin, Wang Bing, "The synchronous generator digital excitation regulator," 978-1-4244-4813-5/10/©2010 IEEE.
- [3] A. Godhwani, M. J. Basler, "A Digital Excitation Control System for Use on Brushless Excited Synchronous Generators," IEEE Transactions on Energy Conversion, Vol. 11. No.3 September 1996.
- [4] Vladimir A. Shikhin, Anna V. shikhina, "Rapid Automatic Thyristor type Excitation Controller Adjustment via Region of Required Quality Construction," 978-1-5386-3669-5/18/\$31.00©2018 IEEE.
- [5] Romina Erceg, Gorislav Erceg, Sejid Tesnjak, "Digital Excitatio System for Small Brushless Synchronous Generator," 0-7803-3932-0.
- [6] R. C. Schaefer, "Application of Excitation Systems for Rotating Exciter Replacement," 0-7803-3919-3-5/97\$10.00 © 1997 IEEE.

- [7] D. M. Sajnekar, S.B. Deshpande, R. M. Moharil, "Efficient PID Controller Tuning Method Selection to be used in Excitation System of Brushless Synchronous Generator," 978-1-5090-0901-5/16\$31.00©2016 IEEE.
- [8] C S Hoong, "Development of Automatic Voltage Regulator for Synchronous Generator," National Power & Energy Conference (PECon) 2014 Proceedinds, Kuala Lumpur. Malaysia.
- [9] Shewit Tsegaye, Kinde A. Fante, "Analysis of Synchronous Machine Excitation System: Comparative Study," International Scholarly and Scientific Research & Innovation 10(12) 2016.
- [10] Jiadan Wei, Qingqing Zheng, Yiwei Yang, "Interrated Ac and Dc Excitation Method for Brushless Synchronous Machine," 978-1-4673-0803-8/12/\$31.00©2012 IEEE.
- [11] N Patin "Control of a DC generator based on a hybrid excitation Synchronous Machine connected to a PWM rectifier," 1-4244-0497-5/06/\$20.00 ©2006 IEEE.
- [12] k. kim, M. J. Basler, A. Godhwani, "Supplymental Control in a modern Digital Excitation System," 0-7803-5935-6/00/\$10.00 © 2000 IEEE.
- [13] Matthew E.Obob, Jafaru Braimah "Single Phase Automatic Voltage Regulator Disign for Synchronous Generator." International Journal of Scientific and Engineering Research, Volume5, Issue 12, December 2014 ISSN 2229-5518.

AUTHOR



Assistant Professor,
Electrical Department, Maharshi
Parshuram College Of Engineering,
Velneswar.