

# DESIGN, ANALYSIS AND OPTIMIZATION OF MOUNTING AND DISMOUNTING TOOL FOR BEARING

Gandhali Anand Doshi

Student, Dept. of Mechanical Engineering, Savitribai Phule Pune University, India

\*\*\*

**Abstract** - A bearing is a machine element that constrains relative motion to only the desired motion and reduces friction between moving parts. The life of a rolling bearing can exceed the life of the machinery in which it performs. In real-world experience bearing failures occur for a variety of reasons. One critical reason bearing fall short of their pre-calculated service life is improper mounting. If the bearings are intended for re-use, dismantling must be performed most carefully; it is imperative that the extracting tool be applied to the ring to be extracted to prevent the rolling elements damaging the raceways. So, the aim of this project paper is to re-design the mounting and dismantling tool for roller bearing used in a compressor which can help avoid future problems and ultimately extend bearing performance and longevity in service.

**Key Words:** Mounting Tool, Dismounting Tool, Bearing, Roller Bearing, Optimization, Tool Design

## 1. INTRODUCTION

A bearing is a machine element that constrains relative motion to only the desired motion and reduces friction between moving parts. In simple terms, roller bearings locate rotating components such as shafts or axles within mechanical systems, and transfer axial and radial loads from the source of the load to the structure supporting it. To minimize friction, heat, power loss and wear, rolling elements such known as rollers or balls with a circular cross-section are located between the races or journals of the bearing assembly. A wide variety of bearing designs exists to allow the demands of the application to be correctly met for maximum efficiency, reliability, durability and performance.

The life of a rolling bearing can exceed the life of the machinery in which it performs. In real-world experience bearing failures occur for a variety of reasons. One critical reason bearing fall short of their pre-calculated service life is improper mounting. When a bearing is mounted improperly without utilizing the correct techniques and tools the bearing's service life will be jeopardized. An estimated 16 percent of all premature bearing failures can be directly attributed to poor fitting and the absence of the correct fitting tools. If the bearings are intended for re-use, dismantling must be performed most carefully; it is imperative that the extracting tool be applied to the ring to be extracted to prevent the rolling elements damaging the raceways. Using best practices for mounting and dismantling a bearing which can help avoid future problems

and ultimately extend bearing performance and longevity in service. Along the way, both the efficiency and productivity of an operation can advance with an associated increase in machinery uptime.

## 1.1 Problems of Existing Technology

Problems facing during mounting and dismantling of bearings are:

- Failure of cap at the top and T joint:  
Due to mechanical force applied by operator, fatigue failure occurs in T joint and cap which is located at the top of the mounting tool.
- Different dismantling tool for different bearing:  
Currently, a separate tool is being used for different bearing size which is not feasible. There is a necessity of common tool for all bearing sizes.
- Failure of dismantling tool because of application of loctite gum.  
When we apply loctite gum on bearing it increases the bond between shaft and bearings. Due to increased adhesiveness, it becomes difficult to dismount the tool and causes failure of the tool.

## 1.2 Objectives

According to existing technology requirement, our objectives for mounting and dismantling tools are as follows:

- To increase the strength:  
Strength of the tool can be increased by changing the existing material i.e. aluminium and steel. This can be achieved by studying various materials and selection of combination of two or more materials suitable for tool.
- To develop an alternative mechanism for dismantling tool:  
There is a necessity of different mechanism for using common tool for all bearings. Tool can be developed in two different parts i.e. one is main body which will remain for all bearings and other part will be accessories attached to main body according to bearings.
- To reduce weight, cost and cycle time of tool  
For operator's comfort, weight and cost of the tool should be less.

## 2. MOUNTING TOOL

The mounting tool designed in this project mainly aims at proper mounting of the bearing without causing damage to the bearing or the shaft surface, so that efficient mounting is achieved within minimum possible cycle time. This, also, improves the productivity of the process.

During mounting of the bearing, the tool made up of stainless steel of grade 4130, is initially pressed upon the bearing required to be mounted. During this process, the bearing is lifted by the jaws of the tool and is held in the tool housing with the help of a spring plunger and thrust pin provided in the lower housing. In the lifted position of the bearing, the compressed spring of the pin exerts spring force on the jaws which helps in proper holding of the bearing in the required position.

After lifting, the bearing is then located at the required position of mounting on the shaft. A hammer is used to provide a sudden impact (hammer blow) of magnitude approximately 600N (assuming weight of operator to be 60 kg) on the tool head. Due to this applied force which exceeds the spring force, the bearing is released by the jaws and it gets properly mounted on the shaft. After the bearing is released, the spring regains its normal position and the tool is ready for next mounting.

Although, the above described process is easy to use, there are some practical limitations which are yet to be resolved. Some of the constraints such as weight of tool, cycle time etc. are mainly focused in this project for optimization purpose.



Fig -1: Mounting Tool



Fig -2: Prototype of Mounting Tool

## 2.1 Results of Mounting Tool

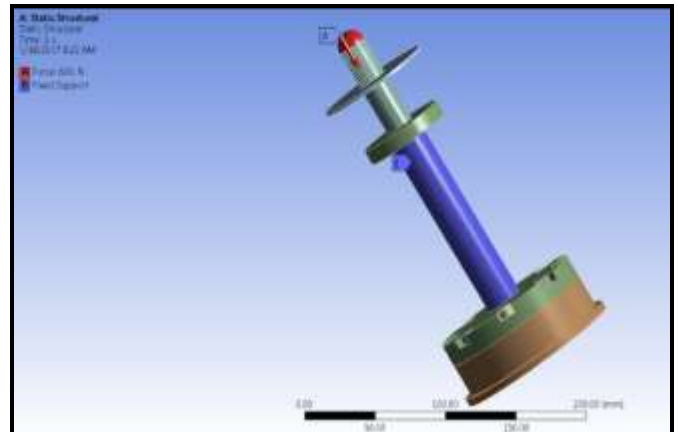

Fig -3: Geometry of Mounting Tool

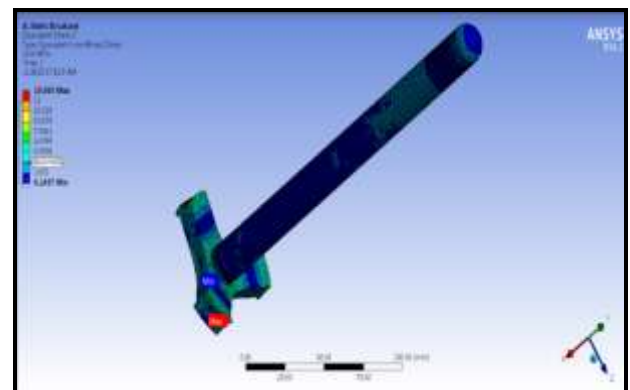

Fig -4: Equivalent Stress of Mounting Tool

From the Figure, it can be observed that maximum stress is occurring at jaws portion. Equivalent stress obtained from analysis is 16.063MPa which is very less than material allowable stress. Therefore, design is safe for the operation.

## 3. DISMOUNTING TOOL

The dismounting tool designed in this project is mainly used for dismounting of cylindrical roller bearings having separable races. The tool is made up of alloy steel 42CrMo4 having considerably high strength needed to sustain a large pulling force of magnitude about 10kN experienced in the dismounting process. The range of inner race diameters, for which this dismounting method is applicable, is 30-40mm.

During the dismounting process, the tool is initially rested upon the application surface using a C-channel. A two-jaw mechanism with a slot is used for properly operating the tool. A hexagonal section is extruded at the center of the slot which is tightly held by a spanner so as to restrict the motion of the central bolt having dia. in the range of 10-12mm.

Due to this fixed constraint, when the bolt head is turned by using a spanner, the jaws which are originally holding the

outer race of the bearing (inner race already being removed) start moving in the upward direction. Thus, the outer race of the bearing is dismantled gradually.

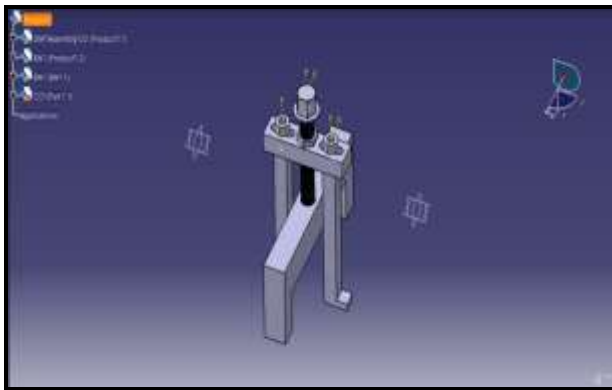

Fig -5: Dismounting Tool

### 3.1 Results of Dismounting Tool

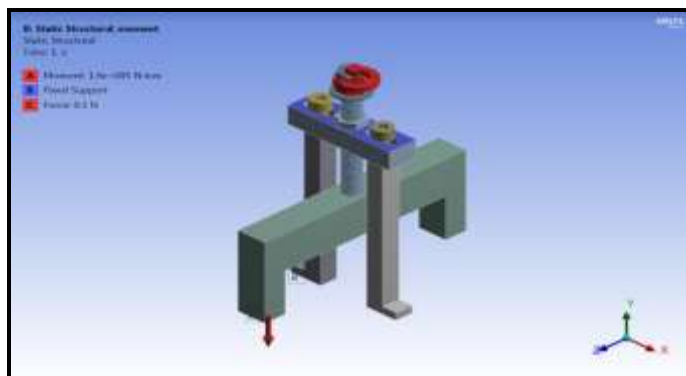

Fig -6: Geometry of Dismounting Tool

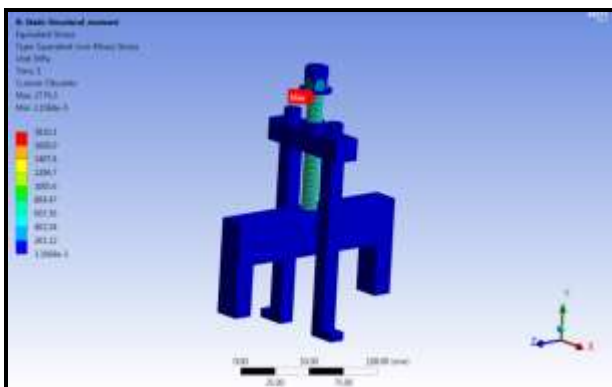

Fig -7: Equivalent Stress of Dismounting Tool

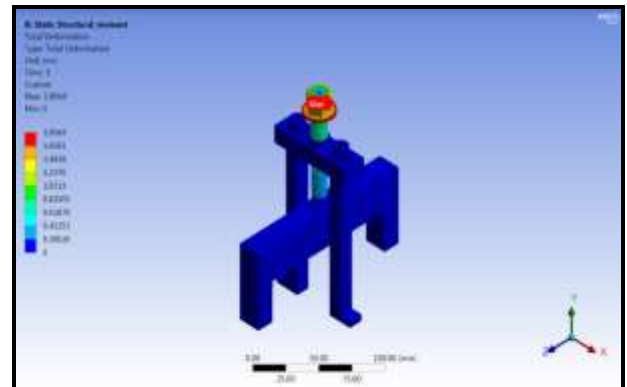

Fig -8: Deformation of Dismounting Tool

From the Figure, it can be observed that maximum stress is occurring on bolt. Equivalent stress obtained from analysis is 1810.1MPa and maximum deformation is 1.856mm which is very less.

### 4. CONCLUSION

In this project, various methods for mounting and dismantling of bearings which are used in the industry have been studied along with the selection of appropriate materials for manufacturing the mounting and dismantling tool. The weight of the mounting tool has also been reduced by about 1.2 kg by efficiently designing the tool as well as by selecting proper materials for manufacturing various parts of the tool. Due to reduction in weight, the cost of the tool is also optimized. In addition to this, the failure of cap and T joint in the mounting tool is also prevented in the improved geometrical design of the tool, as the tool designed in this project is manufactured in a single piece so as to prevent the failure due to stress concentration at the welds.

### REFERENCES

- [1] V.B.Bhandari, Design of Machine Elements, Third edition.
- [2] Serope Kalpakjian, Steven R. Schmid, Manufacturing Processes for Engineering Materials, Fifth Edition.
- [3] <http://www.skf.com/group/products/maintenance-products/mechanical-tools-for-mounting-and-dismounting/bearing-fitting-tools/bearing-fitting-tool-kits/index.html>
- [4] <http://www.maintenanceresources.com/referencelibrary/bearings/morb.htm>
- [5] [http://www.schaeffler.com/remotemedien/media/\\_shared\\_media/08\\_media\\_library/01\\_publications/schaeffler\\_2/manualmountingoperation/downloads\\_7/wl\\_80100\\_3\\_de\\_en.pdf](http://www.schaeffler.com/remotemedien/media/_shared_media/08_media_library/01_publications/schaeffler_2/manualmountingoperation/downloads_7/wl_80100_3_de_en.pdf)
- [6] <http://www.flowcontrolnetwork.com/how-to-properly-mount-bearings/>
- [7] <http://www.nsk.com/services/maintenancerepairs/dismounting.html>