

ROAD SAFETY WITH A SMART HELMET FOR TWO WHEELER VEHICLE WITH AUTOMATIC IGNITION AND ALCOHOL DETECTION

SUHAS R. GOWDA

¹B.E., Mechanical Engineering,
#303 Ganga Paradise, N.R. Road, Karkala, Udupi Dist, India

Abstract - Smart helmet with automatic ignition and alcoholic detection is a project to intimate the alarm signal when there are any alcohol drinking drive. Driving while either intoxicated or drunk is dangerous and drivers with high blood alcohol content (BAC) are at increased risk of car accidents, highway injuries and vehicular deaths. Prevention measures evaluated include license suspension or revocation, impounding or confiscating vehicle plates, enforcing open container bans, increasing penalties such as fines or jail for drunk driving, mandating education for young people, and lowering legal BACs. Also discussed are safety seat belts, air bags, designated drivers, and effective practical ways to stay sober

Furthermore, the plan will urge the implementation of safety and health education by employers with regard to fire safety in multiple-tenant buildings with small businesses. At the same time, it will seek all-embracing strategies to prevent explosion and fire accidents, including measures to prevent dust explosions caused by magnesium alloys. In our project is **“Smart helmet for two wheeler vehicle with alcoholic detection”** used to senses the gas leakage and indicates the alarm with indication.

Key Words: Automation, Alcohol sensor, Microcontroller, Relay, Bluetooth Module, Transformer etc.

1. INTRODUCTION

This is an era of automation where it is broadly defined as replacement of manual effort by mechanical power in all degrees of automation. The operation remains an essential part of the system although with changing demands on physical input as the degree of mechanization is increased.

Degrees of automation are of two types, viz.

- ✚ Full automation.
- ✚ Semi automation.

In semi automation a combination of manual effort and mechanical power is required whereas in full automation human participation is very negligible.

Every single injury and death caused by drunk driving is totally preventable. Unfortunately, over twenty percent of all traffic fatalities in the United State each year are caused by drunk drivers. Thus, drunk driving remains a serious national problem that tragically affects thousands of victims annually.

BLOCK DIAGRAM

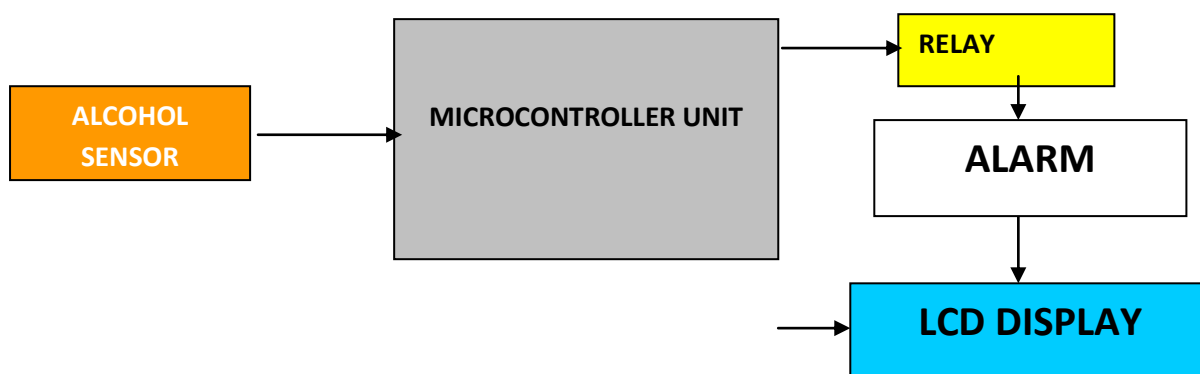

Fig:1

1.1 Alcohol sensor

Liquid sensor (IQL 25) is fixed in the helmet to sense the alcohol consumption.



Fig 1.1: Alcohol sensor

1.2 Bluetooth Module:-



Fig 1.2:- HC-05 Bluetooth module

- It is used for many applications like wireless headset, game controllers, wireless mouse, wireless keyboard and many more consumer applications.
- It has range up to <100m which depends upon transmitter and receiver, atmosphere, geographic & urban conditions.
- It is IEEE 802.15.1 standardized protocol, through which one can build wireless Personal Area Network (PAN). It uses frequency-hopping spread spectrum (FHSS) radio technology to send data over air.
- It uses serial communication to communicate with devices. It communicates with microcontroller using serial port (USART).
- HC-05 is a Bluetooth module which is designed for wireless communication. This module can be used in a master or slave configuration.

1.3 Microcontroller 8051:

- it is 8-bit microcontroller with 40 pins.
- It has three 16-bit timers/counters.
- It also has 32 programmable I/O lines with flash memory.

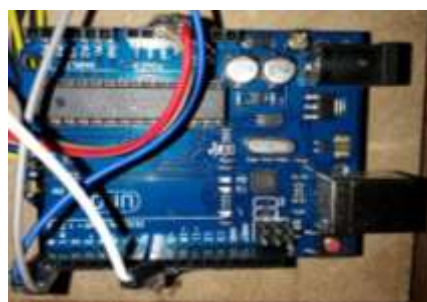

Fig1.3: Microcontroller 8051

1.4LCD: 16 x 2 is used for displaying the latitude and longitude (16 x 2 means 16 character in two lines).



Fig1.4: LCD display

1.5 Relay and Raspberry PI which in real time system is related to the ignition system of the motorcycle.



Fig1.5: Relay

2. CIRCUIT DIAGRAM:

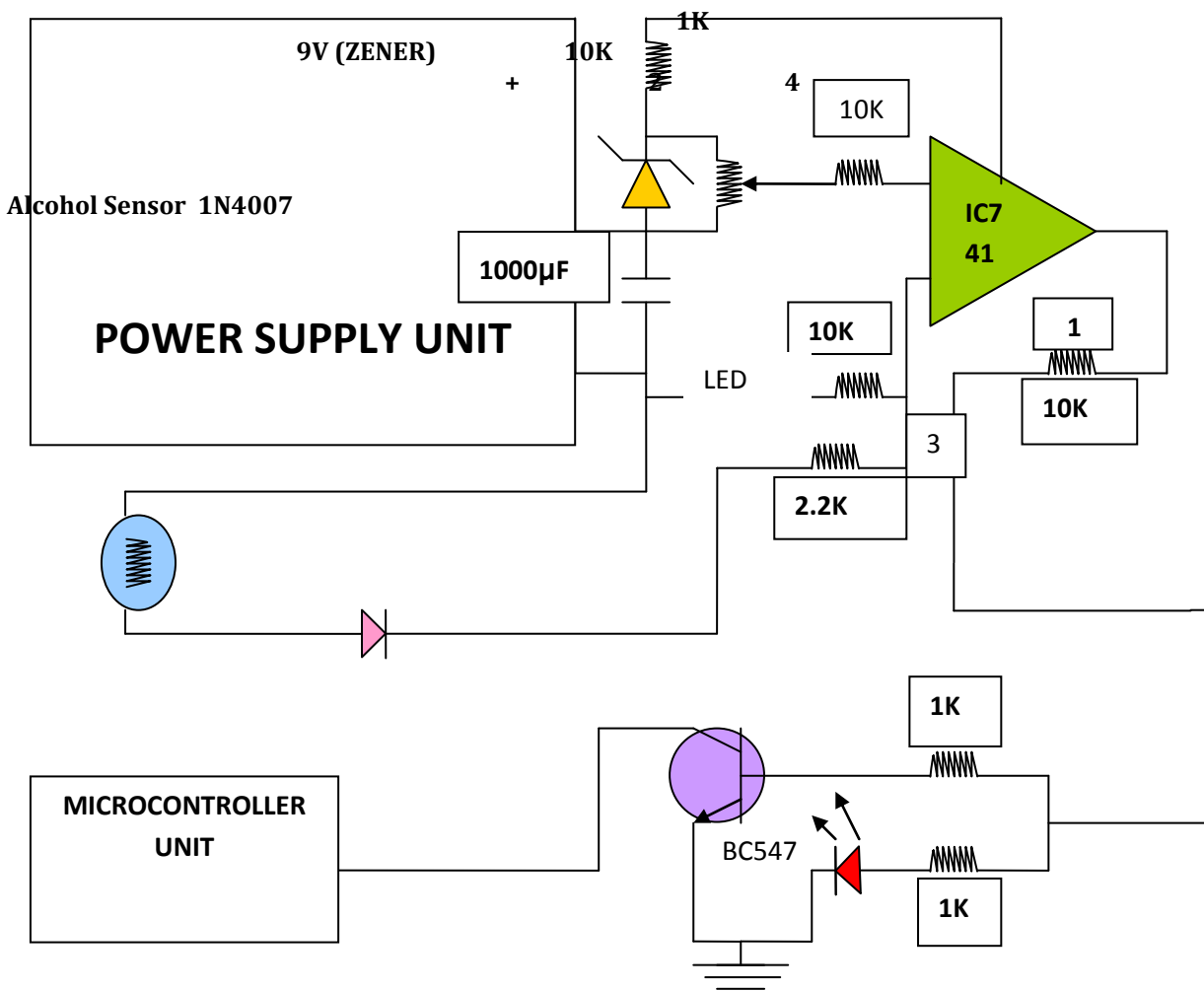

Fig2: Circuit diagram

2.1: AT NORMEL CONDITION:-In normal condition the Resistance of the Sensor is high. The voltages applied to the non-inverting terminal (+ ve) is low when compared to the inverting terminal voltages (- ve). In that time, the OP-AMP output is - Vsat. (I.e. -12 Volt). There is signal given to the microcontroller.



2.2 AT ALCOHOL CONDITION:-In Abnormal condition the Resistance of the sensor is low due to intensity of the light or fire. The voltages applied to the non-inverting terminal (+ ve) is high when compared to the inverting terminal voltages (- ve). In

that time, the OP-AMP output is +V sat. (I.e. +12 Volt). The transistor and in “ON” condition and this signal is given to the microcontroller unit.



2.3 MICROCONTROLLER UNIT:-

The alcohol sensor senses the alcohol contents of the particular room/vehicle. This sensing signal is given to the microcontroller unit. When the current voltage is below the set voltage, the output from the microcontroller activates the relay to function the alarm unit.

2.4 TRANSFORMER:

A transformer is a static (or stationary) piece of which electric power in one circuit is transformed into electric power of the same frequency in another circuit. It can raise or lower the voltage in a circuit but with a corresponding decrease or increase in current. It works with the principle of mutual induction.

2.5 12V POWER SUPPLY UNIT:

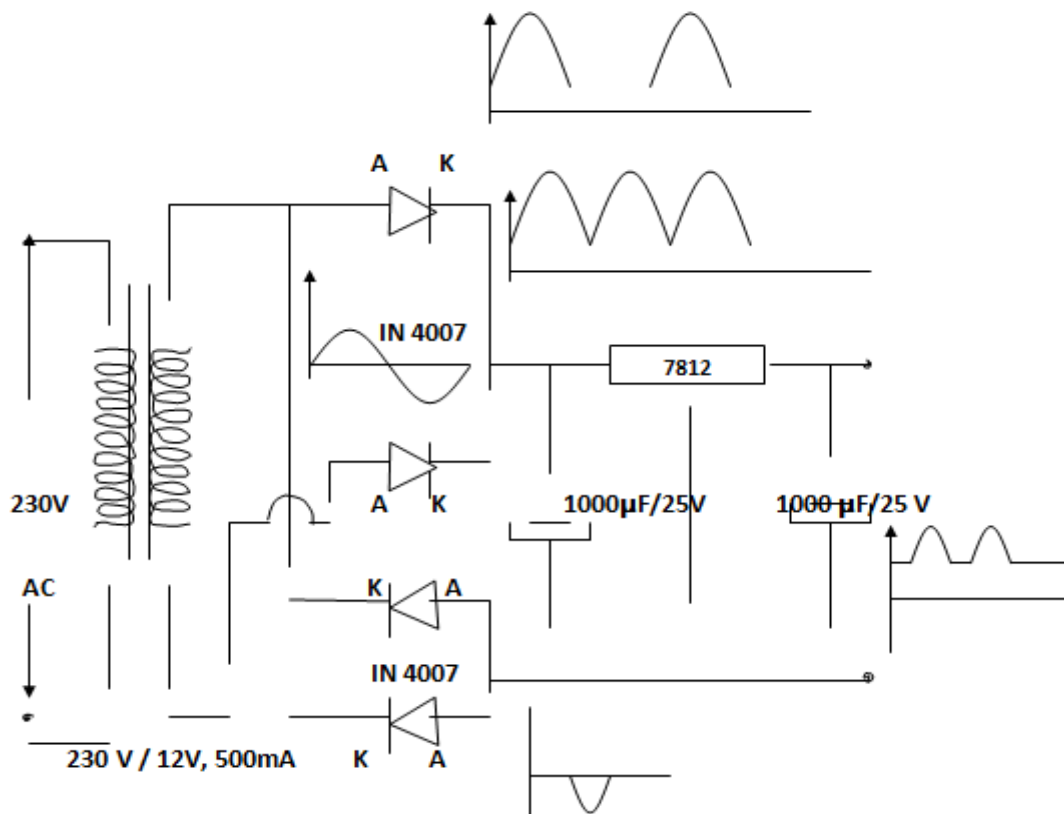

Fig3: Power supply unit

In our project we are using step down transformer for providing a necessary supply for the electronic circuits. In our project we are using a 0-12 and 0-9V transformer.

2.6 RECTIFIER:

The DC level obtained from a sinusoidal input can be improved 100% using a process called full-wave rectification. It used 4 diodes in a bridge configuration.

2.7 REGULATOR:

The output voltage from the capacitor is more filtered and finally regulated. The voltage regulator is a device, which maintains the output voltage constant irrespective of the change in supply variations, load variation and temperature changes. Here we use two fixed voltage regulators namely LM 7812, LM 7805 and LM 7912. The IC 7812 is a +12V regulator IC 7912 is a -12V regulator and IC 7805 is a +5V regulator.

2.8 WORKING PRINCIPLE

The alcohol sensor senses the alcohol contents of the vehicle or air. This sensing signal is given to the microcontroller unit. When there are no alcohol contents in the air, there is no signal given to the microcontroller unit. In our 12 volt power supply is used. The power supply output is given to the control unit. Control unit having three relays, they are connected to the alarm unit. Initially the reference voltage is set with the help of the variable resistance. The alcohol contents is sensed by the sensor and this control signal is given to the microcontroller unit. It sends signal to the display unit that alcohol is detected and the bike doesn't start.



Fig 4: Smart helmet module

3. CONCLUSION

By seeing those many benefits and other factor we came to the conclusion that it is the best alternate in order to reduce the number of head injury happening. This being a very innovative idea should be developed further for improvements. This helmet is developed to decrease the number of road injuries due to drunk driving and helmet skipping. The implementation of the prototype will force people to wear the helmet first in order to drive the vehicle. The number of road traffic accidents would decrease in huge amount after successful implementation of the proposed helmet project compulsorily by the government for the safety of people.

REFERENCES

- [1] Road accidents in India [online] 2007 June 25. Available from: URL: <http://www.easydriveforum.com/f44-share-your-road-experience/road-accidents-in-india-834.html> Articles base directory [online] 2011 Feb. 16 Available from: URL: <http://www.dw-world.de/dw/article/0,,5519345,00.html>
- [2] Article from The Hindu [online] 2011 Feb. 10 Available from: URL: <http://www.hindu.com/2011/02/10/stories/2011021063740500.htm>
- [3] Drunk Drivers Beware Of Saab De-vice, [<http://www.buzzle.com/articles/drunk-drivers-beware-saab-device.html>]
- [4] Nissan to drink drive-proof its vehicles, September 2006, [http://www.nissanglobal.com/EN/NEWS/2007/_STORY/070723-01]
- [5] Drunken driving protection system International Journal of Scientific & Engineering Research Volume 2, Issue 12, December-2011 1 ISSN 2229-5518
- [6] Alcohol sensor and Automatic control system for bike, Volume 2, Issue ICRAET12, May 2012, ISSN Online: 2277-2677.

- [7] SudharsanaVijayan, Vineed T Govind , Merin Mathews, SimnaSurendran , Muhammed Sabah, "Alcohol detection using smart helmet system", IJETCSE, Volume 8 Issue 1 –APRIL 2014.
- [8] Mr.P.Dileep Kumar, Dr.G.N.Kodanda Ramaiah, Mr.A.Subramanyam, Mrs.M.Dharani4, "A Solar Powered Smart Helmet With Multifeatures", International Journal of Engineering Inventions e-ISSN: 2278-7461, p-ISSN: 2319-6491 Volume 4, Issue 10 [June 2015] PP: 06-11.