

VARIABLE FREQUENCY DRIVE USED IN TREADMILL

Abhishek Gowda S N¹, Kiran Kumar M², Naveen Kumar S R³, Niranjan V Gowda⁴,
Dr.N. Saravanan⁵

^{1,2,3,4}VTU passed out Students, Department of EEE, ACS College of Engineering, Bangalore, Karnataka, India

⁵Associate Professor, Rajarajeswari College of Engineering, Department of EEE, Bangalore, Karnataka, India

Abstract - A treadmill is normal machine in the advanced family and wellness activity. With the belt support constrained by the motor, individuals can run or walk inactively at various paces. Moreover, clients can encounter distinctive running condition, for example, level land, tough or variable speed to achieve diverse preparing purposes, with the helper electronic gear on the treadmill. Most DC brush motors are utilized in the VFD support for the past treadmill to spare expense. Be that as it may, its shortcomings are the high disappointment proportion of carbon-brush and commutator device, high support cost and wasteful low-speed torque. Along these lines, an endeavor has been made to receive the AC motor with the variable recurrence drive to improve the shortcomings of the DC motor.

Key Words: Variable frequency drive, AC drive, Variable speed drive, Inverter drive.

1. INTRODUCTION

The essential capacity of a variable speed drive (VSD) is to control the progression of vitality from the mains to the procedure. Vitality is provided to the procedure through the motor shaft. Two physical amounts depict the condition of the pole: torque and speed. To control the progression of vitality we should in this manner, eventually, control these amounts. By and by, both of them is controlled and we talk about "torque control" or "speed control". At the point when the VSD works in torque control mode, the speed is controlled by the heap. In like manner, when worked in speed control, the torque is controlled by the heap. At first, DC motors were utilized as VSDs on the grounds that they could undoubtedly accomplish the required speed and torque without the requirement for modern machine. Notwithstanding, the advancement of AC variable speed drive innovation has been driven incompletely by the craving to copy the brilliant execution of the DC motor, for example, quick torque reaction and speed precision, while utilizing rough, cheap and upkeep free AC motors.

II. AC DRIVE WORKING PRINCIPLE

A. CIRCUIT DIAGRAM

For understanding the fundamental principles behind AC drive operation needs understanding 3 basic section of AC drive: the Rectifier unit, DC Bus and also the electrical

converter unit. The offer voltage is first off submit to a rectifier unit wherever in gets regenerate into AC to DC supply, the 3 section offer is fed with 3 section full wave diode wherever it gets converts into DC offer. The DC bus includes with a filter section wherever the harmonics generated throughout the AC to DC conversion ar filtered out. The last section consists of associate degree electrical converter section that contains with six IGBT wherever the filtered DC provide is being regenerate to similar curved wave of AC provide that is supply to the ac motor connected to it.

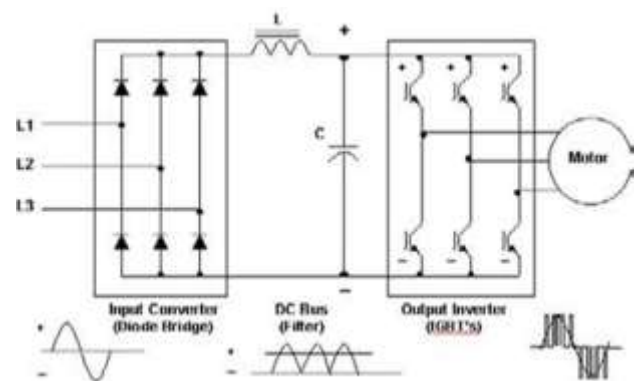

Figure 1 AC Drive

From the ac motor working rule, we all know that the synchronous speed of motor (rpm) depends upon frequency. Therefore by variable the frequency of the ability provides through AC drive we will management the electric motor speed:

$$\text{Speed (rpm)} = \text{Frequency (Hertz)} \times 120 / \text{No. of poles}$$

Where:

Frequency = Electrical Frequency of the power supply in Hz.
No. of Poles = Number of electrical poles in the motor stator.
Thus we can conveniently adjust the speed of an AC motor by changing the frequency applied to the motor.

B. PULSE WIDTH MODULATION (PWM)

There is additionally in a {different way|in our own way otherwise} to form the AC motor work on different speed by dynamical the no. of poles, however this alteration would be a phase change of the motor. As the VFD provides the frequency and voltage of output necessary to vary the speed of a motor, this is often done through Pulse breadth

Modulation VFDs. Pulse width modulation (PWM) variable frequency drive produces pulses of varying widths which are combined to build the required waveform How AC Drive Controls Motor Speed

As the AC drive provides the frequency and voltage of output necessary to control the speed of an AC motor, this is done through PWM VFDs. PWM drives produce pulses of varying widths which are combined to build the required waveform. A diode bridge is used in some converters to reduce harmonics. PWM drives produce a current waveform that more closely matches a line source, which reduces undesired heating. PWM VFD have almost constant power factor at all speeds which is closely to unity. PWM drives can also operate multiple motors on a single variable frequency drive. Thus the carrier frequency is derived from the speed of the power device switch remains ON and OFF. It is also called switching frequency. Therefore higher the carrier frequency higher the resolution for PWM contains. The typical carrier frequency ranges from 3KHz to 4 KHz or 3000 to 4000 times per second as compared with older SCR based carrier frequency which ranges from 250 to 500 times per second. Thus it is clear as much as higher the carrier frequency higher will be the resolution of output waveform. It is also noted that the carrier frequency decreases the efficiency of the VFD because it led to increase the heat of the VFD circuit.

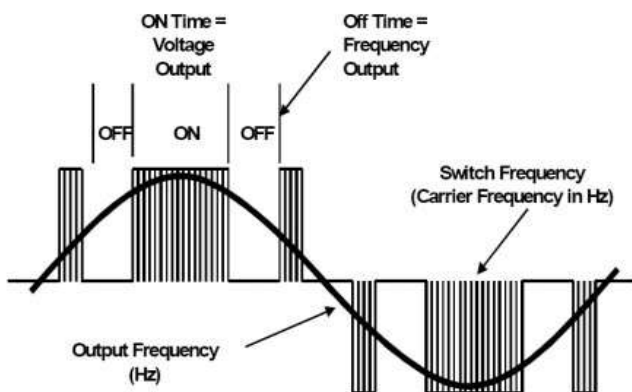

Figure 2 Pulse Width Modulation Waveform

C. COMPONENTS OF VFD

Rectifier - Converts the alternating current (AC) input power to direct current (DC) power DC link- Stores the DC power to be used by the converter. These are the capacitors that are typically in the back of VFD. Converter - The IGBT (Inverse Gate Bipolar Transistor) inverter is the heart of the converter component. It under direction of the control circuit provides the PWM (Pulse width Modulation) output of the motor a controlled frequency and voltage. Control Circuit - This is where the programming takes place and controls all the working of the VFD the brains of the operation.

D. AC DRIVES - FLUX VECTOR CONTROL USING PWM

To emulate the magnetic operative conditions of a DC motor, ie, to perform the sector orientation method, the flux-vector drive must grasp the spatial relation of the rotor flux within the AC induction motor. With flux vector PWM drives, field orientation is achieved by electronic means that instead of the mechanical commutator/brush assembly of the DC motor. Firstly, data concerning the rotor standing is obtained by feeding back rotor speed and spatial relation relative to the stator coil field by means that of a pulse encoder. A drive that uses speed encoders is said as a “closed-loop drive”. conjointly the motor’s electrical characteristics ar mathematically sculptural with microprocessors wont to method the information. The electronic controller of a flux-vector drive creates electrical quantities comparable to voltage, current and frequency, that ar the variables, and feeds these through a modulator to the AC induction motor. Torque, therefore, is controlled indirectly.

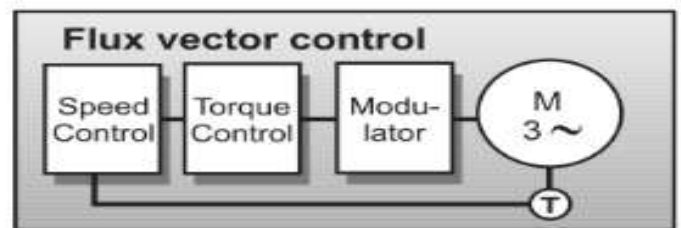

Figure 3 Flux Vector Control

E. AC DRIVES - DIRECT TORQUE CONTROL

With a torque response that's usually ten times quicker than any AC or DC drive. The dynamic speed accuracy of DTC drives are going to be eight times higher than any open loop AC drives and adore a DC drive that's exploitation feedback DTC produces the primary “universal” drive with the potential to perform like either an AC or DC drive

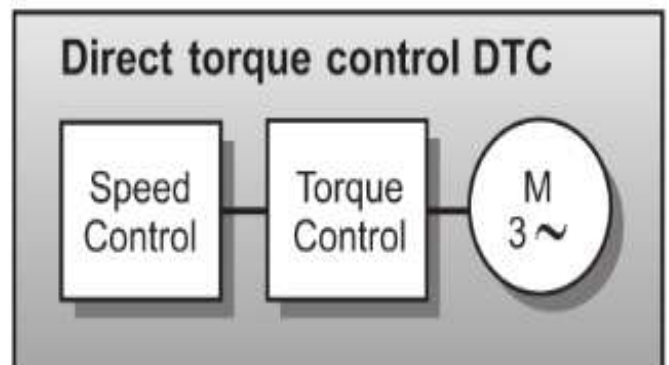

Figure 4 Direct Torque Control

II. OBJECTIVE OF THE PROJECT

- Large energy savings at lower speed.
- Increased life of rotating components due to lower operating speed.
- Reduced noise and vibration level.
- Reduction of thermal and mechanical stresses.
- Lower KVA
- High power factor.

III. MODEL OF THE PROJECT



Figure 5 Model of Project

IV. CONCLUSION

As the direct torque management methodology is entorqued during this project thus on eliminate the feedback system from motor to realize the high torque at terribly low speed that is impractical within the dc drive that is presently accessible within the market.

REFERENCES

- [1]. S.K. Mazumder, "High-Frequency Inverters: From Photovoltaic, Wind, and Fuel-Cell based Renewable- and Alternative-Energy DER/DG Systems to Battery based Energy-Storage Applications", Book Chapter in Power Electronics handbook, Editor M.H. Rashid, Academic Press, Burlington, Massachusetts, 2010
- [2]. V. Gureich "Electronic Devices on Discrete Components for Industrial and Power Engineering", CRC Press, New York, 2008, 418 p
- [3]. Arendt Wintrich; Ulrich Nicolai; Werner Tursky; Tobias Reimann (2010),
- [4]. Trzynadlowski, A.M. (2010). Introduction to Modern Power Electronics. Wiley. pp. 269–341
- [5]. Wheeler; Wijekoon, Klumpner (July 2008). "Implementation of a Hybrid AC/AC Direct Power Converter with Unity Voltage Transfer Ratio" (PDF). IEEE Transactions on Power Electronics. 23 (4): 1918–1986. doi:10.1109/tpel.2008.924601.
- [6]. Bose, Bimal K. (February 2009). "Power Electronics and Motor Drives Recent Progress and Perspective". IEEE.
- [7]. U.S. Department of Energy. "Smart Grid / Department of Energy". Retrieved 2012-06-18.
- [8]. Garcia, X.T.; Zigmund, B.; Terlizzi, A.; Pavlanin, R.; Salvatore, L. (Mar 2006). "Comparison Between FOC and DTC strategies for Permanent Magnet". Advances in Electrical and Electronic Engineering. 5 (1–2)..
- [9]. Kazmierkowski, M. P.; Franquelo, L.; Rodriguetz, J.; Perez, M.; Leon, J. (Sep 2011). "High Performance Motor Drives". IEEE Industrial Electronics Magazine Sept 2011. Vol. 5 no. 3. pp. 6–26.
- [10]. Noguchi, Toshihiko; Takahashi, Isao (Sep 1984). "Quick Torque Response Control of an Induction Motor Based on a New Concept". IEEJ: 61–70.
- [11]. Takahashi, Isao; Noguchi, Toshihiko (Sep 1986) (Sep–Oct 1986). "A New Quick-Response and High-Efficiency Control Strategy of an Induction Motor". IA-22 (5). IEEE Trans. on Industry Applications: 820–827. Computation Conference Wroclaw, Poland, August 18-22, 2014.

[12]. Foo, Gilbert (2010). Sensorless Direct Torque and Flux Control of Interior Permanent Magnet Synchronous Motors at Very Low Speeds Including Standstill. Sydney, Australia: The University of New South Wales.

BIOGRAPHIES



Name: Dr N Saravanan
Qualification: DEEE, BE, ME, PhD
Working Under: VTU Karnataka
Teaching Experience: 14 Years
Organization: RRCE
Place: Bangalore
Designation: Associate Professor
Department: EEE