

IOT ENABLED BLDC MOTOR DRIVEN WATER PUMP EMPLOYING ZETA CONVERTER

Afsal Lais¹, Abhijith R S², Akash M R³, Joseph Danish⁴, Beena M Varghese⁵

^{1,2,3,4}Student, Department of Electrical and Electronics Engineering, MACE, Kerala, India

⁵Associate Professor, Dept. of Electrical and Electronics Engineering, Kerala, India

Abstract - Taking into consideration the growing energy demand in the world a fact that cannot be overlooked is that with the existing centralized energy generation the load demand cannot be met in the near future. This thought has ignited minds to adopt the integration of renewable energy sources. Among the available sources of energy solar has proved over the years that it can supply clean energy for almost 25 years without the need of any maintenance or regular repairs. The initial investment for wind mills are huge compared to solar and the space required for installing wind mills are also more. Thus solar can be installed with minimal cost and space compared to the windmill. The study of an efficient DC-DC converter was made with simulations and inferences where made after comparing the results with buck-boost converter. The use of high frequency switching results in high voltage stress across the switches and this is not satisfactory for the long life of the converters thus a better control scheme has been studied where the switching frequency is kept constant. The DC link voltage is changed by varying the duty cycle for the zeta converter, which indirectly controls the speed of the BLDC motor. The suitability of the system at practical operating condition is demonstrated through simulation results using MATLAB followed by experimental validation. The system is expected to deliver improved control over the water flow compared to conventional methods. The inclusion of voice control is expected to deliver an efficient method of integrating IOT than the conventional app based virtual buttons.

1. INTRODUCTION

With the emergence of modern semiconductor switching devices and power electronic converter we were able to design and develop speed control techniques that are much more efficient and effective than conventional techniques. The conventional method that we use to pump water in any application involves the use of centrifugal pump that employ an induction motor for driving the impeller, which has no means to control its speed. If we wanted to control the speed of the motor we can implement vector speed techniques. But these techniques are complex. Thus using a BLDC motor makes the speed control efficient and easy at the same time.

Since we are seeing an considerable increase in the power consumption over last few decades. The demand and supply is not matching each other. Thus its not economical to add more power plant to the grid. In order to relieve the stress

on the government to establish more power plants, we can add several micro generating units or micro grid in to the utility grid there by increasing flexibility. In an survey we were able to find that there are over 40 pumping stations under the water authority in 20km radius. If we are able to integrate renewable energy in to these units we can save a considerable amount of energy. Thus the system proposed in this paper tries to implement an water pumping system that is powered by solar energy derived from solar panels.

For driving the BLDC motor we need a three-phase supply which can be obtained from an inverter. This involves designing a three phase inverter using semiconductor switches. For obtaining a three phase output from the inverter we have to provide the gate pulses to the semiconductor switches. These gate pulses are giving in response to the hall signals obtained as feedback from the motor. Thus the speed control of BLDC motor is a closed loop operation.

Conventional method of speed of BLDC involves varying the PWM signal given as gate pulse to the inverter. This method has proven to increase the stress on the switching devices. In order to eliminate the stress we can vary the DC link voltage of the input side voltage of the inverter. This will vary the output voltage of the inverter and their by varies the speed of the motor.

In order to eliminate the need of an operator near the device we can implement an remote control. All though we can implement this using mobile application this method is not practical in future were we expect the devices to be interactive with the user. Thus we implement a voice based system that can take commands from the user and take actions. In applications were we want to pump water for irrigation if we automate the process it can often lead to errors. This is because the weather can be unpredictable thus we need to bring the feedback of the farmer for controlling the system. Were the farmers can sent there feedbacks and with those feedbacks the system will be able to change its parameters to adapt to new situations.

1.2 OPERATION OF THE SYSTEM

The structure of proposed SPV array fed BLDC water pumping system employing a zeta converter is shown in Figure 1. The proposed system consists of (left to right)

a SPV array, a zeta converter, a VSI, a BLDC motor and a water pump. The BLDC motor has an inbuilt encoder. The pulse generator is used to operate the zeta converter. A step by step operation of proposed system is elaborated in the following section in detail. The SPV array generates the electrical power. This electrical power is fed to the motor-pump via a zeta converter and a VSI. The SPV array appears as a power source for the zeta converter as shown in Figure 2. Ideally, the same amount of power is transferred at the output of zeta converter which appears as an input source for the VSI. In practice, due to the various losses associated with a DC-DC converter, slightly less amount of power is transferred to feed the VSI. The pulse generator generates, through MPPT algorithm, switching pulses for IGBT (Insulated Gate Bipolar Transistor) switch of the zeta converter. The INC-MPPT algorithm uses voltage and current as feedback from SPV array and generates an optimum value of duty cycle. Further, it generates actual switching pulse by comparing the duty cycle with a high frequency carrier wave. In this way, the maximum power extraction and hence the efficiency optimization of the SPV array is accomplished.

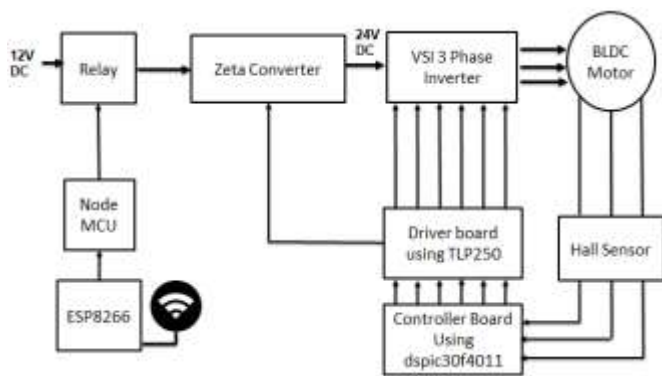

Figure 1: Block Diagram of the System

1.3 ZETA CONVERTER

Similar to the SEPIC DC/DC converter topology, the ZETA converter topology provides a positive output voltage from an input voltage that varies above and below the output voltage. The ZETA converter also needs two inductors and a series capacitor, sometimes called a flying capacitor. Unlike the SEPIC converter, which is configured with a standard boost converter, the ZETA converter is configured from a buck controller that drives a high-side PMOS FET. The ZETA converter is another option for regulating an unregulated input-power supply, like a low-cost wall wart. To minimize board space, a coupled inductor can be used. This article explains how to design a ZETA converter running in continuous-conduction mode (CCM) with a coupled inductor [3].

1.4 BASIC OPERATION OF ZETA CONVERTER

Figure 3 shows a simple circuit diagram of a ZETA converter, consisting of an input capacitor, C_{IN} ; an output capacitor,

C_{OUT} ; coupled inductors $L1a$ and $L1b$; an AC coupling capacitor, C_C ; a power PMOSFET, $Q1$; and a diode, $D1$. Figure 3 shows the ZETA converter operating in CCM when $Q1$ is ON and when $Q1$ is OFF. To understand the voltages at the various circuit nodes, it is important to analyze the circuit at DC when both switches are off and not switching. Capacitor C_C will be in parallel with C_{OUT} , so C_C is charged to the output voltage, V_{OUT} , during steady-state CCM. Figure 3 shows the voltages across $L1a$ and $L1b$ during CCM operation. When $Q1$ is off, the voltage across $L1b$ must be V_{OUT} since it is in parallel with C_{OUT} . Since C_{OUT} is charged to V_{OUT} , the voltage across $Q1$ when $Q1$ is OFF is $V_{IN} + V_{OUT}$; therefore the voltage across $L1a$ is V_{OUT} relative to the drain of $Q1$. When $Q1$ is on, capacitor C_C , charged to V_{OUT} , is connected in series with $L1b$; so the voltage across $L1b$ is $+V_{IN}$, and diode $D1$ sees $V_{IN} + V_{OUT}$.

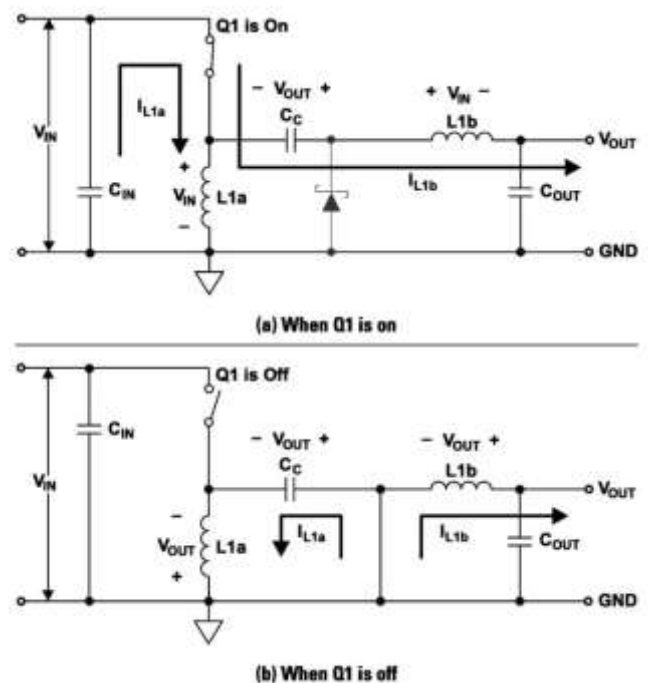

Figure 2: zeta converter

1.5 COMMUTATION OF BLDC MOTOR

The BLDC motor is controlled using a VSI operated through an electronic commutation of BLDC motor. An electronic commutation of BLDC motor stands for commutating the currents owing through its windings in a predefined sequence using a decoder logic. It symmetrically places the DC input current at the centre of each phase voltage for 120. Six switching pulses are generated as per the various possible combinations of three Hall-effect signals. These three Hall effect signals are produced by an inbuilt encoder according to the rotor position. A particular combination of Hall-effect signals is produced for each specific range of rotor position at an interval of 60. The generation of six switching states with the estimation of rotor position is

tabularized in Table 1. It is perceptible that only two switches conduct at a time, resulting in 120 conduction mode of operation of VSI and hence the reduced conduction losses. Besides this, the electronic commutation provides fundamental frequency switching of the VSI, hence losses associated with high frequency PWM switching are eliminated.

Table 1: Switching States for VSI

Rotor position $\theta(^{\circ})$	Hall Signals			Switching States					
	H_1	H_2	H_3	S_1	S_2	S_3	S_4	S_5	S_6
NA	0	0	0	0	0	0	0	0	0
0-60	1	0	1	1	0	0	1	0	0
60-120	0	0	1	1	0	0	0	0	1
120-180	0	1	1	0	0	1	0	0	1
180-240	0	1	0	0	1	1	0	0	0
240-300	1	1	0	0	1	0	0	1	0
300-360	1	0	0	0	0	0	1	1	0
NA	1	1	1	0	0	0	0	0	0

VSI employed for the control of the BLDC motor contains six semi-conductor switches that are placed across three branches, with each branch containing two switches each of these six switches are turned ON using gating pulses that are given in a specific pattern so as to generate a three phase output. The pattern of gating pulse for the switches are determined from the position of rotor poles with respect to the stator. The position of the rotor is determined with the help of three hall effect sensor placed inside the BLDC motor. By comparing the signals from these hall sensors against a switching state table we can determine the sequence for turning ON the six semiconductor switches in the Voltage Source Inverter. By changing the switching frequency we can adjust rms output voltage of the inverter, which will also adjust the speed of the BLDC motor.

1.6 IOT INTERFACE DEVICES

Since we are living in a world that is more connected than yesterday or the day before that. The technologies strive to connect one another and thus IOT is gaining a lot of momentum. One important reason for that is due to the errors that are caused by the human intervention, in the case of a machine it does not need any rest or it won't even get tired thus a continuous operation is possible, the aim of the IOT in this project is to incorporate a remote control capability for the motor and a voice based control strategy, considering the case of the irrigation of the fields in a locality by the irrigation departments what if the farmer can manually ask the system to pump the motors for water and the system can shift the time of operation based on the weights and if it can shift the weights based on such enquiries then that system will be able to shift the operating times to provide the best results for the farmers. In the conventional system a paid personal is kept in service for monitoring the water level and this person has the responsibility of calling the pump operator for operating the motor, and from the survey conducted we found that these people are unreliable at times and this has caused a lot of

damage to the farmers and their fields. By bringing the farmers close to the system we can eliminate the communication gap.



Figure 3: IOT Block Diagram

2. DESIGN OF THE SYSTEM

Design of system involves the design of zeta converter, power supply for the controller and driver circuit for driving the inverter MOSFET.

2.1 DESIGN OF ZETA CONVERTER

Duty cycle is formulated as

$$D = \frac{V_{dc}}{V_{dc} + V_{in}} = \frac{24}{24 + 12} = 0.66$$

Average value of current through DC link is given by

$$I_{dc} = \frac{P_m}{V_{dc}} = \frac{60}{24} = 2.3A$$

Input inductor L1:

$$L1 = \frac{DV_{mpp}}{f_{sw}\Delta I_{L1}} = \frac{0.66 * 12}{20000 * 2.4 * 0.06} = 2.7 * 10^3 = 2.7mH$$

Output inductor:

$$L2 = \frac{(1 - D)V_{dc}}{f_{sw}\Delta I_{L2}} = \frac{(1 - 0.66) * 24}{20000 * 2.04 * 0.06} = 2.8 * 10^3 = 2.8mH$$

Input capacitor:

$$C1 = \frac{DI_{dc}}{f_{sw}\Delta V_{c1}} = \frac{0.66 * 2.4}{20000 * 24 * 0.1} = 3.3\mu F$$

Minimum angular speed:

$$\omega_{min} = 2\pi f_{min} = \frac{2\pi NP}{120} = 2\pi * \frac{800 * 6}{120} = 251.2r = rad/sec$$

Output capacitor for minimum speed:

$$C2_{min} = \frac{I_{dc}}{6 * \omega_{min} * \Delta_{dc}} = \frac{2.4}{6 * 251.2 * 24 * 0.14} = 470\mu F$$

Output capacitance for rated speed:

$$C2_{rated} = \frac{I_{dc}}{6 * \omega_{rated} * \Delta_{dc}} = \frac{2.4}{6 * 471 * 24 * 0.14} = 252\mu F$$

2.2 DESIGN OF CONTROLLER

The controller board houses all the components that are required for the satisfactory working of the controller IC and the components of the system that rely on the controller. The controller chosen is DPIC30F4011 which has 24-bit wide instructions, 16-bit wide data path, 48k bytes on-chip ash program space, 2k bytes of nonvolatile data EEPROM. The power input for the DSPIC30f4011 is 5V. For obtaining a steady 5V supply a step down transformer is used. The 230V AC is first stepped down to 12V. 12V AC is then rectified using a bridge rectifier. This voltage is given as input a 7805 regulator IC that will enable us to regulate the 12V to 5V. Then the 5V is given as input to the DSPIC at it's pins 11,12,20,21,32,31,40,39

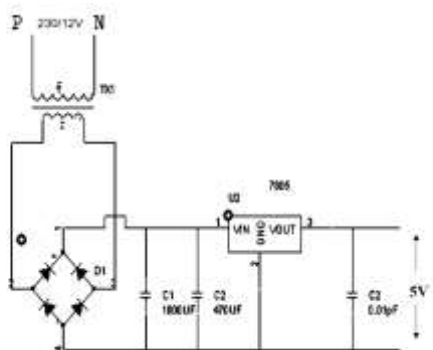

Figure 4: Power supply for DSPIC30F4011

2.3 DESIGN OF DRIVER BOARD

The driver circuit is shown in the figure 4. When a high value is provided as input to the TLP at the pins 2 and 3, we expect the TLP250 to deliver a high voltage in our case a 12V to appear at the pin 7, when that happens the NPN transistor switches ON and the PNP transistor switches OFF, the zener diode provided ensured that the voltage given out by the driver circuit is regulated. When the input pulse to the TLP250 is low, the NPN transistor turns OFF and the PNP transistor will turn ON. When this happens the diode will be forward biased and the output will be negated thus the MOSFET will be turned OFF. From the law of conservation of

energy we know that energy can neither be created nor destroyed. Thus the extra voltage that we obtained at the output of the driver circuit is given from a power supply unit within the driver board which consists of a step down transformer, half wave rectifier and a capacitor filter, the output of this unit will be DC supply with magnitude of 12V.

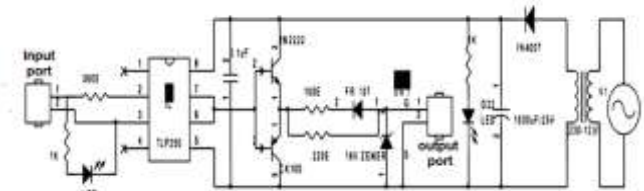

Figure 5: MOSFET Gate Driver Circuit

2.4 DESIGN OF IOT INTERFACE

For implementing the IOT enabled operation we can use the conventional method of app based operation but it will be difficult for the farmers with their limited knowledge to use these applications. Thus a voice controlled system will be easier for them to use. The google assistant based devices are gaining a lot of momentum and google being a successful company can offer great support in the future. For implementing such system we need to establish a communication with system and the consumer. For that we are using nodeMCU and ESP8266. ESP8266 is wi-fi transmitter and receiver. The Nodemcu is development board that can be programmed to take necessary actions based on the command received from the google assistant. For linking the google assistant with system we have to send the command from the phone's microphone to IFTTT server where we can code the if and the corresponding action associated with the if clause. From there the action is sent to our IOT enabling server that gives us the power to host our own dedicated space for the system, this space can also be linked to a mobile application named blync. The blync app can be used to monitor and control the motor remotely. The instruction from this space will be pushed to the nodeMCU via the ESP8266 and the nodeMCU will send control signals to the relay module for controlling the motor.

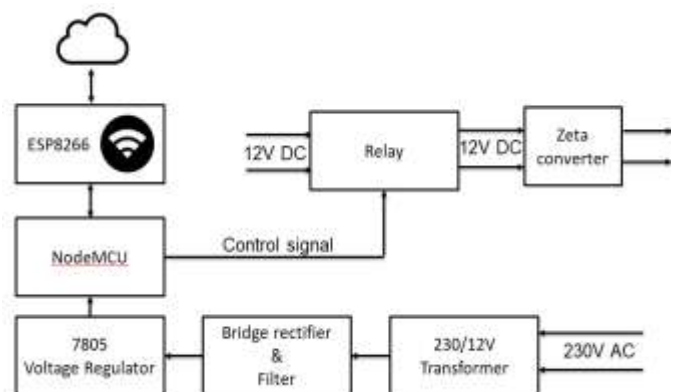

Figure 6: IOT Block Diagram.

3. SIMULATION OF THE SYSTEM

The following Simulink Model shows PI controller fed with reference value and observed value. The reference value is set to 200V and the observed value is fed from the output of the zeta converter. Find the error of the zeta converter and this value is given as the input of PI controller. The output of PI controller is given to a saturation block that limits the output between a predetermined limit. A Repeating sequence is compared with the PI controller output to form the switching pulse for the zeta converter.

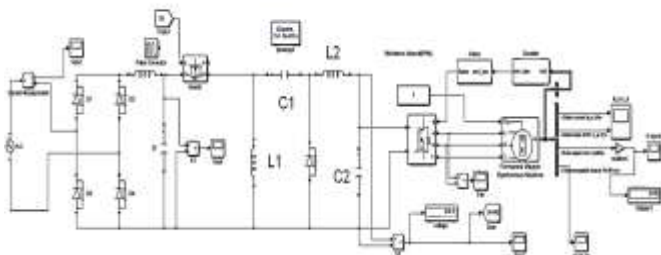

Figure 7: Simulation of Three phase Inverter Fed BLDC Motor Drive In Closed Loop

Table -2: Simulation Parameters

Parameters	Specification
Input voltage Vin	187V AC
Zeta converter Input inductance L1	2.2mH
Zeta converter output inductance L2	2.2mH
Zeta converter input capacitance C1	470mF
Zeta converter output capacitance C2	100µF
Proportional constant Kp	0.1
Integral constant Ki	0.05
Sawtooth time value & Output value	1ms , 70V
Reference voltage	200V
Torque(Nm)	0.1

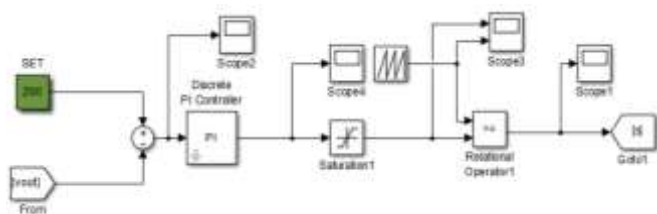

Figure 8: PI Controller

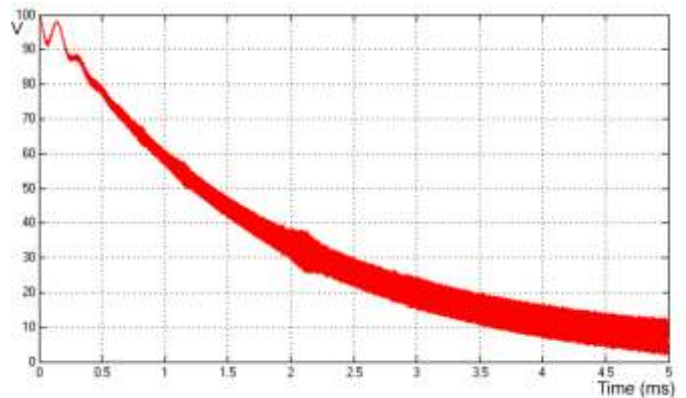

Figure 9: Represents the Error = (Reference Value)- (Observed Zeta Output)

Figure 9 shows the output of the adder block in the pi controller were the observed voltage at the output of zeta converter is subtracted from the reference value.

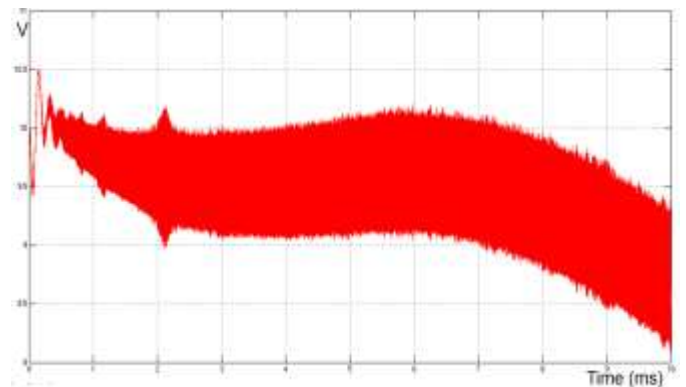

Figure 10: Output of PI Controller

Figure 10 shows the output of the PI Controller were the kp value is set as 0.1 and ki value is set as 0.05 through trial and error method.

Figure 11 and Figure 12 shows the sawtooth reference wave and the output of the relational operator.

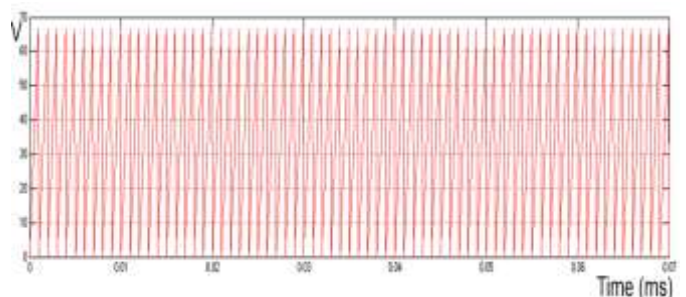

Figure 11: Sawtooth signal

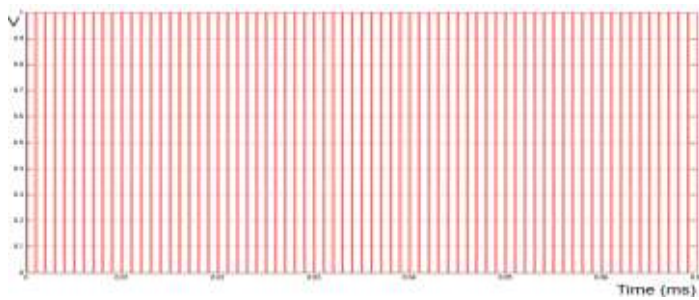

Figure 12: Output of Relational Operator

Figure 12 shows the motor torque and Figure 13 shows the speed. The output speed gradually reaches 1000rpm.

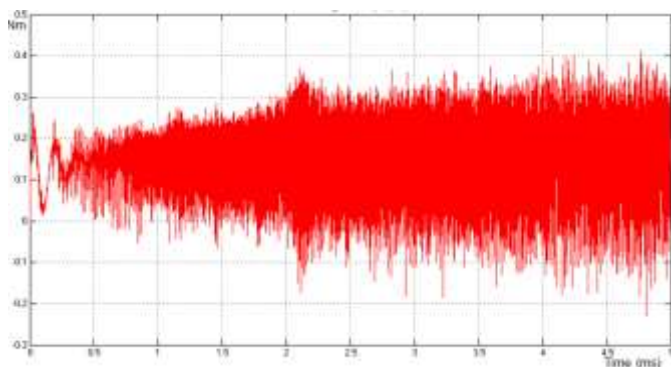

Figure 13: Motor Torque Developed

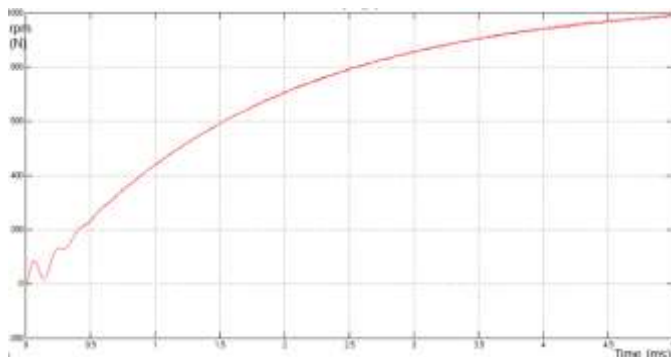

Figure 14: Motor Speed

From the above simulations it can be concluded that the zeta converter can be used to control the speed of the BLDC motor. The reference given to the adder block can be adjusted to achieve desired results. The output of the pi controller after the relational operator can be used to turn ON and OFF the MOSFET. MOSFET is turned ON when the Figure 11 shows a high value and is OFF when the Figure 11 shows a LOW value. Thus we are able to control the DC link voltage. This change in voltage will result in the voltage given to the BLDC motor, therefore changing its speed. All these processes will take some time to achieve the desired values. This can be observed in the figures shown above.

4. HARDWARE SETUP

Figure 14 shows the working model of the system. Starting with the transformers for powering various components of the system. A 230V/12V 1A transformer powers the zeta converter and a 230V/12V 0.5A transformer powers the controller and the driver boards. The voice control hardware is marked as 5 and 6 in the Figure 14.

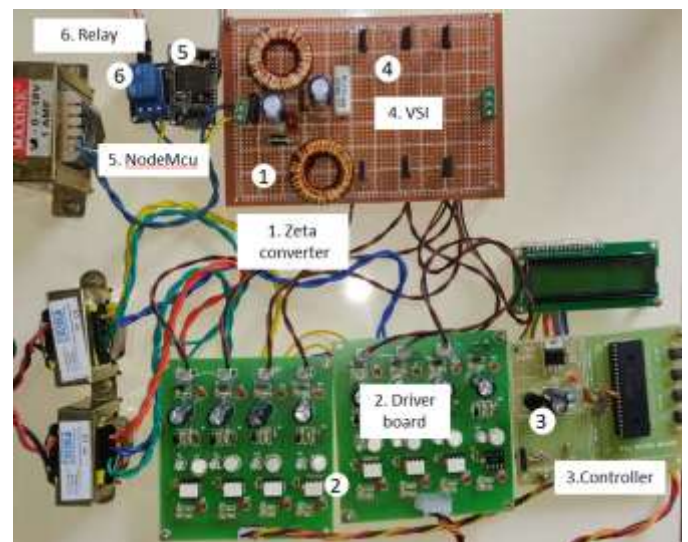

Figure 15: Hardware Setup

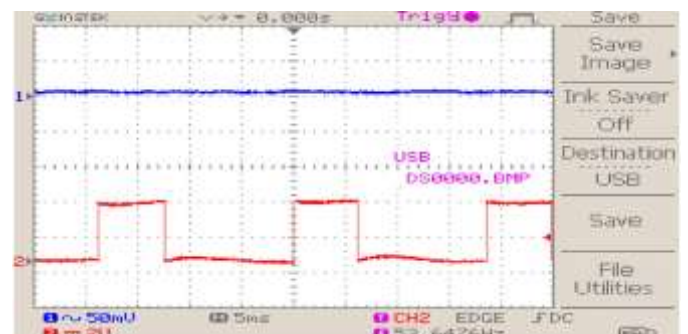

Figure 16: Controller output PWM signal to driver board

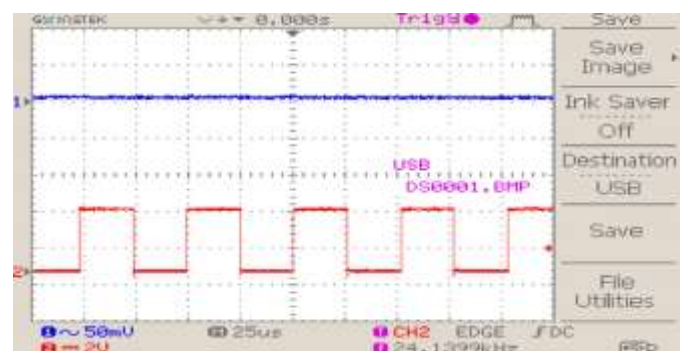

Figure 17: Zeta Converter MOSFET Gate Pulse

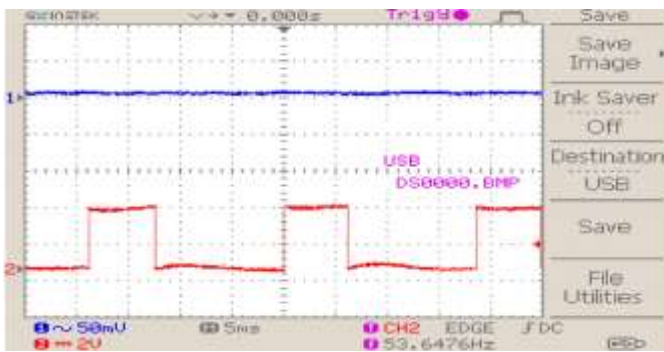

Figure 18: Hall Sensor Output

5. CONCLUSIONS

The conventional method of water pumping was very primitive in its capabilities in term of speed control. As more and more industries try to make there production line highly productive and profitable even a minute error in the quantity of liquids in packaged products can make a huge difference in the profit margin. Thus we require a more precise control over the rate of flow of liquids in such cases. As our country is facing lot of deficiency in power its has become a great concern. This has motivated the ministry of new and renewable energy sources division of India to invest more on the deployment of renewable energy resources in the country. Thus the inclusion of solar energy will promote the use of renewable energy for driving the motor. The advantages and desirable features of both zeta converter and BLDC motor drive has contributed in designing a simple, efficient, cost effective and reliable water pumping system based on solar PV energy. Simulation results using MATLAB/Simulink and experimental performances were examined to demonstrate the working of the water pumping system. The design of zeta converter was studies and demonstrated using a prototype. A better control scheme for the BLDC motor was also studies and demonstrated using a prototype. In addition the design of SPV array was also studied.

REFERENCES

- [1] Md Musthafa Kamal, Speed Control of BLDC Motor Using Intelligent Controller, Student Conference on Engineering and Systems, May. 2014.M. Young, The Technical Writer's Handbook. Mill Valley, CA: University Science, 1989.
- [2] Denizar Cruz Martins, Zeta Converter Operating in Continous Conduction Mode Using The Unity Power Factor Technique , 1996 Sixth International Conference on Power Electronics and Variable Speed Drives), 23-25 sept 1996.
- [3] Ahmed Saeed Ahmed, MPPT Algorithms:Performance and Evaluation, IET Science, Measurement Technology, vol.9, no.3, pp.351-361, May 2015
- [4] A.H. El Khateb, N. Abd.Rahim, J. Selvaraj and B.W. Williams, "DC-to-DC Converter with Low Input Current Ripple for Maximum Photovoltaic Power Extraction,"IEEE Trans. Ind. Electron., vol.62, no.9, pp.5776-5785, Sept.2015.



Figure 19: Set speed & Actual speed



Figure 20: Set speed & Actual speed



Figure 21: Set speed & Actual speed

Figure 20 shows the set speed as 1060rpm and the PI controller tunes the speed of the BLDC motor to reach 1060rpm.

In Figure 21 shows the PI controller has tuned the system so that the actual speed is very much close to the set speed of 1120rpm.