

EXPERIMENTAL MODEL DESIGN AND SIMULATION OF AIR CONDITIONING SYSTEM FOR ENERGY MANAGEMENT

Francis T. Omigbodun¹, Bankole I. Oladapo², Oluwole K. Bowoto³, Funso P. Adeyekun⁴

^{1,2,3}School of Engineering and Sustainable Development, De Montfort University, Leicester, UK

⁴Department of Electrical and Electronics Engineering, Afe Babalola University, Ado Ekiti, Nigeria

Abstract - The government on every level is on the move to reduce the energy consumed by different appliances. The air conditioning unit is one of the major appliances at home that consume a notable amount of energy. It cools air from outside the building and passes it into the mainstream from the cooled air compressor and ejects heat out of the building. The purpose of this research is to model, simulate and experiment the operations of the air conditioning unit, which are the control of power and the adjustment of the temperature inside the building. Also, knowing the rate of energy consumption and the factors that affect the energy consumed in cooling a particular environment. We analyzed the model design in MATLAB and then applied the system to minimize the energy consumption by air conditioning systems without affecting the comfort of the end users. The experimental research was carried out in a large room of about 6.79m long, 3.85m wide and 2.89m high. The temperature was controlled to 25.752°C, and 25.624°C utilizing 1.7202kWh and 1.670kWh in the model design and experiment respectively with air conditioning unit of 5HP. Furthermore, the results of this research were compared with the other reported work to emphasize the outstanding results. It can be concluded from the research that the results obtained from the measuring device and the results from the simulated model are consistent.

Key Words: Air-condition; Energy consume; MATLAB; Model; Control power

1. INTRODUCTION

Ventilation of buildings has a significant influence on building energy consumption as well as the productivity, satisfaction and the wellbeing of the occupants [1, 2]. The American Society of Heating, Refrigerating, and Air-Conditioning Engineers (ASHRAE) agreed on adequate ventilation with the temperature that ranges from 20°C to 30°C [3, 4]. Observations from buildings used for supporting business production, such as checkup goods show that moisture ratio is obliged to be decreased to sure drop leaves. One of the methods employed to dehumidify the rainy-day air is the desiccant method [5-7]. There has been a rising interest in sinking the energy consumption in buildings. Heating, ventilation and air conditioning systems are the biggest consumer of energy in buildings [7, 8]. The examination of the performance and operational methods of air conditioning systems is of great consequence in the successful handling of energy [6, 7]. The altered approaches to control operations in support of rainy-day building environments can be roughly classified into the following categories: standard methods and computational intelligence techniques [8-10]. Buildings account for approximately 42% of the consumption of final energy [13] in France and around 20% to 40% in other urbanites. Luis [14] reports with the intention of the share of AC logic pro heating, ventilation, and air conditioning; this has currently been elevated to the vertex leading energy aid in the residential and non-residential sector. Wong [15] estimates with the intention of it; represent alone third of the total power consumption Pro Residential housings in Hong Kong. Air conditioning is a device that works based on temperature and humidity (the air in a reasonable condition). The principle of operation of Air conditioning is different for different Air conditioning systems. Design features Installation and the system entirely mainly consist of a cooling cycle using a vapour compression cycle, which acts on the suction and discharge principle to call the media. In heating, the medium includes air or steam. Once the desired temperature has been reached, the medium is delivered to the heat exchangers (in the event of a water medium or cold air) [12, 13]. The area is directly conditioned or cooled (in the case of an air medium) and the heat generated is sent to vent of the system. The heat sink may be air-cooled or water-cooled depending on the method used. When the room temperature rises, heat is drawn out to allow the relative room temperature to drop, this is known as cooling. The weather is also compensated for so that the moisture in the air is increased or decreased to control the humidity of the sky to a reasonable condition [12-14]. This is also known as the comfort zone, which is within a temperature range of 22°C to 27°C. The load on the cooling system in a room is due to these heat sources; heat from the inside of the building and that from the outside. The heat from the exterior consists of heat that is conducted from outside through the walls, the roof and the floor into the building as well as radiant heat from the sun passing through the glass-made outer building parts such as walls, doors, windows, etc. The heat from the internal include fever from lighting devices and other electrical appliances such as electric motors, blowers, etc. are considered. Leakage of air at high temperatures in the room is neglected in different cases [14, 15].

1.1 Objective

In this study, the model design of the air conditioning unit of offices was developed to predict the thermal performances and also the energy usage of the system within a specified time. The purpose of this work was to verify data from the simulated model with the testing data from the air-conditioner unit measure with the use of a power meter. Although there are different work by the researcher [17] on air conditioning unit using fuzzy logic to control the temperature in a building. Also, there is recent research [1, 12] on annual energy consume using a numerical model and the amount of energy saved using a solar system. The result presented by [18, 19] was extensively extended with more advanced control techniques that improved air conditioning system and method of measuring energy in a building. One of the significant now ideal in this work is the use of Matlab platform to model, control and generate the air conditioning system of a building to calculate the energy consume and propose a reduction method using Simulink component. The Simulink block was used to develop and implement the analytical model of the building and also describe the physical phenomena of the building element. This method enables the designers to describe the system as a physical structure (schematic of the system), the energy consumes and also the cost of consumption, not just abstract mathematical equations. It also facilitates to decide the energy size of the air conditioning system needed by the size of the building, considering the thermal loads and evaluating the maximum cooling power required. This makes it applicable and desirable by institutions and industries at large for the implementation.

2. MATERIALS AND METHODS

This study was designed to reflect the energy consumption rate of the air conditioning unit in the house. Experiments were carried out under different conditions with the use of air actual conditioning unit. Tests were conducted using a regulated cooling system utilizing about 7.5kWh from capacity power plants of 2,630W in a room of 6.79m long, 3.85m vast and 2.89m high space. This was done while the room temperature is set to 25°C. The versatile data recorder (data logger) used to record the temperatures of specific distinct points (locations) that are needed and at the same time, marked the average temperature from outside the building. The internal temperature of the room was measured with a digital power meter of scale power plants. The air conditioning was divided into two classes to ensure accurate air conditioning throughout the two hours. The air conditioner was in the off state for 1hour 15minutes, then for the next 45minutes period, making up two hours. A comparison between the average results obtained from measuring instruments and the average effects of the model design to validate the research. The model parameters for the building put into consideration are shown in Table 1 and 2

Table -1: Model Design parameters for First Room

Building Part	Thickness [m]	Area [m ²]	Mass [kg]	Specific Heat [JK/kg]	Thermal Conductivity [W/mk]
Floor	0.32	40.23	18660	839.7	0.1232
Ceiling	0.31	27.7	13176	845.6	0.1125
Wall	0.45	27.8	13764	867.1	0.1445

Table2 Model Design parameters for Second Room (Room2)

Building Part	Thickness [m]	Area [m ²]	Mass [kg]	Specific Heat [JK/kg]	Thermal Conductivity [W/mk]
Floor	0.32	35.34	18660	839.7	0.1232
Ceiling	0.31	20.17	13176	845.6	0.1125
Wall	0.45	20.18	13764	867.1	0.1445



Figure -1: Rooms with air conditioners used to experiment.



Figure 2 Measuring AC voltage power plants and power plants using the power meter.



Figure 3 Measuring the temperature inside and outside the room using a multi-purpose data recorder.

3. MODEL DESIGN FOR AIR CONDITIONING SYSTEM.

For raising the building, a modular deal with projected was used. The castle produces results from the integration of all places to stay model. The parameters put into consideration include walls, windows and doors which are friendly with the free background and interactive with the public areas to keep through conductive, convective and radiative excitement conveying.

In the simulation, the excitement sources to influence the building thermodynamics are heating systems and the sunlight effect on the building. The excitement losses considered are the excitement tide through walls and windows and the control of the ventilation process. The operation of the air conditioner can be easily adapted to model simulations of heat applied by Simulink, a tool in the program MATLAB as evident in Figures 4 and 5.

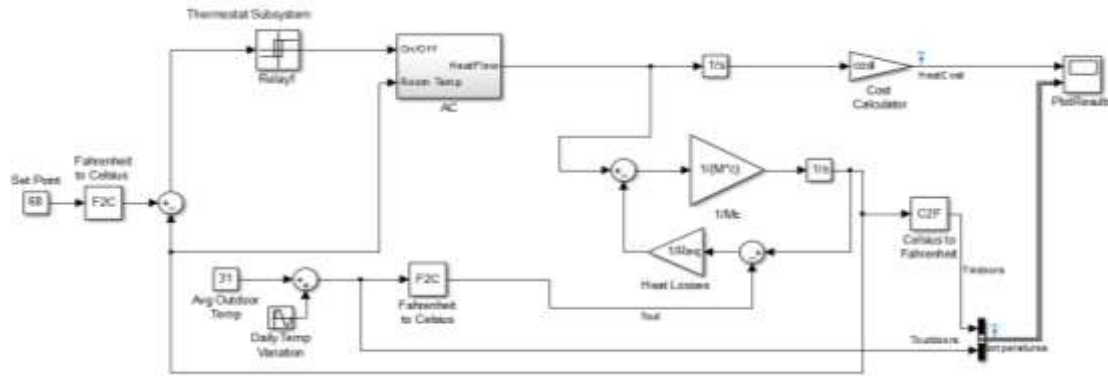

Figure 4 Model of the operation of the air conditioner installed inside the program MATLAB and Simulink.

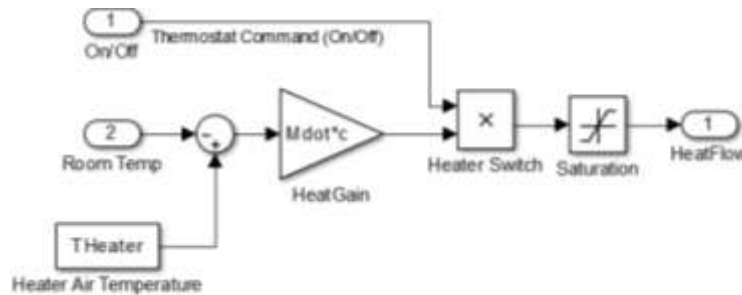

Figure 5 The compacted model of the air conditioner with the cooling element

The blocks apply phenomena like convective or conductive excitement conveying and explain the thermodynamics of a material or a combination of equipment, which is characterised by a thermal bulk. Heat tide and warmth sensors are used to rate parameters of appeal and excitement flow. Warmth sources were also used to mark out the inputs in the development. The first Simscape blocks utilised for the air conditioning unit in this research are presented in fig 4. For modelling the radiative and convection phenomena, the deal with projected by Selah [15, 16] was used. The general model for continuity, the flow of energy and cold air diffusion of air were also used. The model in Figure 5 can be written as follows.

$$\frac{dQ}{dt} = (T_{room} - T_{AC}) Mdot.C \tag{1}$$

Where is the full air flow from the air conditioning unit in the room? C is the heat capacity of air at constant pressure. M dot is the air flow rate in the system measure in kg/hr. T_{out} is the temperature of the air from the system and T_{room} is the temperature of the room during the experiment.

$$\left(\frac{dQ}{dt}\right) losses = \frac{T_{out} - T_{room}}{Req} \tag{2}$$

$$\frac{dT_{room}}{dt} = \frac{1}{M_{air} C} \left(\frac{dQ_{AC}}{dt} - \frac{dQ_{losses}}{dt} \right) \tag{3}$$

3.1. The cooling source model

During the simulation, only one possible heat source was considered, which is the solar radiation effect on the building wall. For modelling heating sources, an analytical approach was used. The solar radiation transmitted through the windows to the air, furniture and floor of the room, which affects their temperature by causing it to rise [16]. So a fraction p from solar radiation qs is transmitted to the floor, and a fraction (1-p) is transmitted to the air and stuff inside the room. The equations that define these heat fluxes are:

- [10] R.L. Navale, R.M. Nelson, use of genetic algorithms and evolutionary strategies to develop an adaptive fuzzy logic controller for a cooling coil comparison of the AFLC with a standard PID controller, *Energy Build.* 45 (2012) 169–180.
- [11] Ashrae Handbook, HVAC Systems and Equipment, ASHRAE Publications, 2008.
- [12] S. Soyguder, M. Karakose, H. Alli, Design and simulation of self-tuning PID-type fuzzy adaptive control for an expert HVAC system, *Expert Syst. Appl.* 36 (2009) 4566–4573.
- [13] Bankole. I. Oladapo, S. Abolfazl Zahedi, Surya C. Chaluvadi, Satya S. Bollapalli, Muhammad Ismail, Model design of a superconducting quantum interference device of magnetic field sensors for magnetocardiography *Biomedical Signal Processing and Control*, 46,2018,116-120
- [14] Luis Pérez-Lombard, José Ortiz, Christine Pout A review on buildings energy consumption information *Energy and Buildings*. Volume 40, Issue 3, 2008, Pages 394-398
- [15] Samuel O. Afolabi, Bankole I. Oladapo, Christianah O. Ijagbemi, Adeyinka O. M. Adeoye, Joseph F. Kayode, Design and finite element analysis of a fatigue life prediction for safe and economical machine shaft, *Journal of Materials Research and Technology*, Volume 8, Issue 1, January–March 2019, Pages 105-111
- [16] T. Hübert, L. Boon-Brett, G. Black, U. Banach, Hydrogen sensors – a review, *Sens.Actuators B* 157 (2011) 329–352.
- [17] Bankole I. Oladapo, Vincent A. Balogun, Adeyinka O. M. Adeoye, Ige E. Olubunmi, Samuel O. Afolabi, Experimental analysis of electro-pneumatic optimization of hot stamping machine control systems with on-delay timer, *Journal of Applied Research and Technology*, Volume 15, Issue 4, August 2017, Pages 356-364
- [18] Ciprian Lapusan, Radu Balan, Olimpiu Hancu, Alin Plesa. Development of a Multi-Room Building Thermodynamic Model Using Simscape Library. *Energy Procedia* 85 (2016) 320 – 328.
- [19] <http://venturesafrica.com/is-the-new-electricity-tariff-justifiabe/>. (Retrieved on 5/16/2016)
- [20] <http://www.vanguardngr.com/2015/06/the-new-electricity-tariffs-from-july-2015/>. (Retrieved on 5/16/2016)
- [21] Christian O. Ijagbemi, Bankole I. Oladapo, Harold M. Campbell, Christopher O. Ijagbemi, Design and Simulation of Fatigue Analysis for a Vehicle Suspension System (VSS) and its Effect on Global Warming, *Procedia Engineering*, Volume 159, 2016, Pages 124-132.