

SAR REDUCED PROXIMITY COUPLED MICROSTRIP ARRAY ANTENNA FOR 5G CELLULAR APPLICATIONS

Chinjulekshmi P S¹, Sruthi Maria Abraham², Hari S³

¹Mtech student, Dept of ECE, MZCE, Kerala, India

²Asst.Professor, Dept of ECE, MZCE, Kerala, India

³Professor, Dept. of ECE, MZCE, Kerala, India

Abstract - Our aim is to design an antenna which is of compact size and also capable of providing low Specific Absorption Rate at millimetre Wave frequencies. If an antenna works in higher frequencies especially in mmwave ranges then it will cause high path loss. So in order to reduce the path loss array antennas are used. A novel linear 1×5 proximity coupled array antenna is given, that works over the ranges of 27 GHz to 28GHz. And this array antenna which is something a fresh concept in mobile communication especially in higher frequencies. This give gain of 4db and low SAR worth at mmWave frequencies. And best suited for 5G applications while considering the health issues caused by mobile phones.

Key Words: Proximity Coupling, Array Antenna, mmWave, 5G, cellular communication

1. INTRODUCTION

5G cellular communication system provides a far better level of performance than the previous generations of mobile communications systems. 5G technology itself not just the next version of mobile communications, evolved from 1G,2G,3G,4G and now 5G. Even these technologies uses different digital techniques used and advanced modulation formats, wireless communication technologies from 1G through 4G have deals with limited bandwidth, and also trying to serve a fast growing number of users wanting more services that consume ever-increasing bandwidth[1]. In this context the millimeter wave 5G network provides a much better network performance due to the much wider RF bandwidth it utilizes. Millimetre wave communication also capable of acquiring high data rate, enhanced spectral efficiency, improved coverage, and reduced power consumption[2].

While dealing with mmWave, mobile terminals requires new techniques in the design of antennas for mobile-station (MS) and base-station (BS) systems in order to overcome the high path loss effects associated with higher frequencies. So in order to overcome the signal degradation caused by high pathloss microstrip patch array antennas and phased arrays are widely studied as possible candidates with features such as high gain, beam steerable radiation patterns and low profile for mmWave applications. Beam-steerable phased array antenna, one of the most important blocks for

5G cellular systems, can be achieved by creating planar arrays by the assembly of smaller linear arrays[3]. This linear arrays plays an important role in improving the gain and also extending the coverage by the formation of pencil beams. Generally parallel fed circuit is used to form a vertical pattern with a high gain and a low side lobe levels. But it has a large loss especially in the millimeter wave band. Series fed microstrip patch array antenna is effective for the millimeter wave applications since it has low feeding loss[4].

The radiation that are coming out from mobile phones affects the human health and is a subject of interest, as a result of the enormous increase in mobile phone usage throughout the world. These EM waves are absorbed by the human tissue and this cause the severe damage to tissues. The recent series of reports, using the leakage of serum albumin, suggest that repeated exposure to cellular-phone-like microwave radiation can alter BBB (Blood Brain Barrier) permeability at SARs that are well below the maximal permissible level for cellular telephones (1.6 W/kg [6]). So it is necessary to decrease the interaction of electromagnetic energy towards human head from mobile handset when in use[5]. The measurement of absorption of electromagnetic waves by the human tissue is known as the specific absorption rate (SAR). In the field of antenna designing SAR value is important. There are some factors which will influence SAR value like size, position, radiated power and type of antenna used etc[6]. Here the SAR value is much lower than the existing 4G phone antennas and thus provide a safe zone operation of mobile phones even at higher frequency

In this paper, a 1 x 5 array is formed and analysed for the performances at 28GHz. We get a gain about 4.09db and SAR value nearly 1.01w/kg. Section II presents the antenna design. In Section III, the results and discussion. Finally, summary of the work is given as conclusion in Section IV

2. ANTENNA DESIGN

The antenna operates from 27.5 GHz to 28.5 GHz with a center frequency of 28 GHz and is constructed from two stacked Taconic RF-35(tm) substrates. Relative permittivity of the material is about 3.5 with thicknesses of 0.508 mm each. A 50 Ω microstrip line on the lower

substrate feeds the resonant microstrip patch elements on the upper substrate with spacings of SP1 to SP4 as shown in Fig. 1. In this case coupling occurs at the end of the first feedline at the open termination upwards to the patch above then downwards through the substrate to the next feedline below the patch on its other side. The length of each of the feed is as long as λg , the spacing between the patches but varies slightly due to the open-termination length (SI) this will also varies according to the size of the patches and the width of the feedlines. Coupling of maximum power occurs when SI is lower than $\lambda g/4$. To realize lower sidelobe levels in the E-plane for the linear antenna in [7], the inequality in patch widths accounted for different radiation amplitudes of each element optimized with a Dolph-Chebyshev distribution [8] to give the desired results. To cancelling out the reflections, the slits are placed on either side of the microstrip line as opposed to creating the slits along one side of the microstrip line. Simulation results of this linear array is shown in fig . This linear array can be used to form the phase array antenna which is the main block of the 5G communication system. Increasing the number of linear arrays increases the gain and forms pencil beams to extend coverage ranges significantly and compensate for signal degradation due to high path loss. In [9], 6×5 planar array is formed by using linear arrays which is shown in Fig 4.

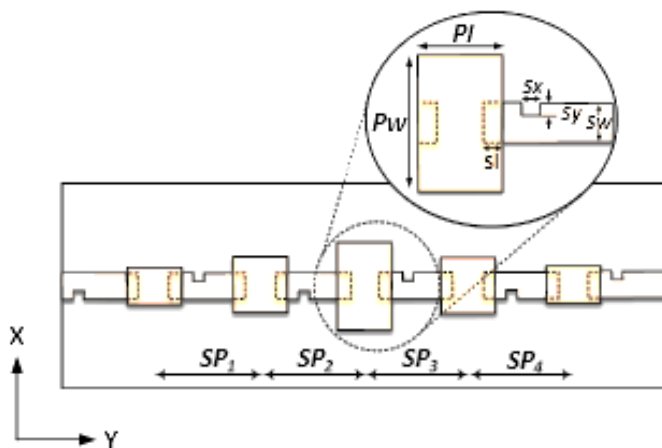

Fig1. 1×5 array antenna

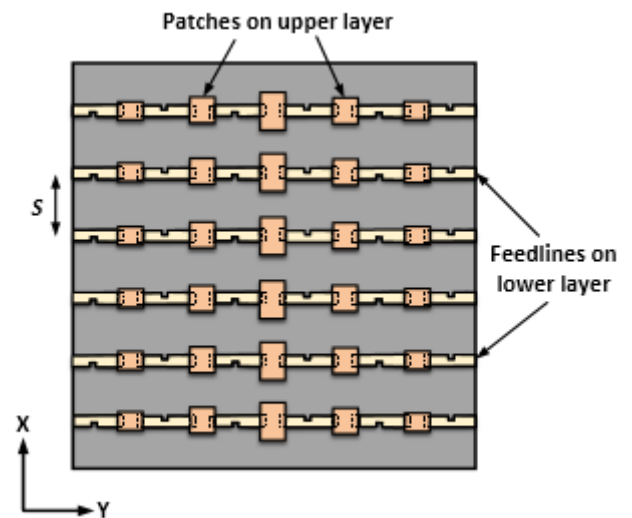

Fig 2. planar array configuration

To reduce the radiation from this antenna towards human body complimentary split ring resonator structure is used. Metamaterials in wireless communication allows the use of different frequency ranges for applications that are more desirable. The versatility achieved by applying metamaterials is more important because there are many classes of regulated frequencies and standard characteristics that must be followed, like UWB system. The Complementary Split Ring Resonator is a type of Metamaterial, its characteristics cannot be found in nature, like electric and magnetic negative parameters. In this system hexagonal shaped CSRR is used and which is optimized to get the desired result. This structures are simulated in Ansys Electronics Desktop. Fat and skin structures are used to find out the amount of radiation that are emanating from the antenna towards human body. CSRR implemented linear array is given in Fig 3.

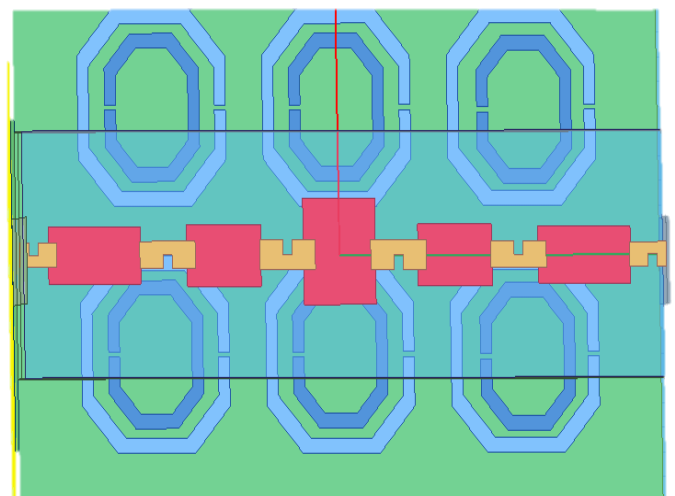

Fig 3. Linear array with CSRR structure

3. RESULTS AND DISCUSSION

Linear array formed in Fig1 is analysed in hfss and obtained 6.48db gain at 28GHz. 2D and 3D plot is shown in figure 4(a) and (b). S parameter plot is given in Fig 5. From this it is clear that plot shows low values from 27.5 GHz to 28.5GHz, which is our operating frequency. Gain and SAR value of the proposed antenna is obtained. Antenna shows acceptable gain and specific absorption rate of 1.01, which is much lower than acceptable level. Gain plots are shown in Fig 6(a) and (b). maximum gain obtained is nearly 4.09db.

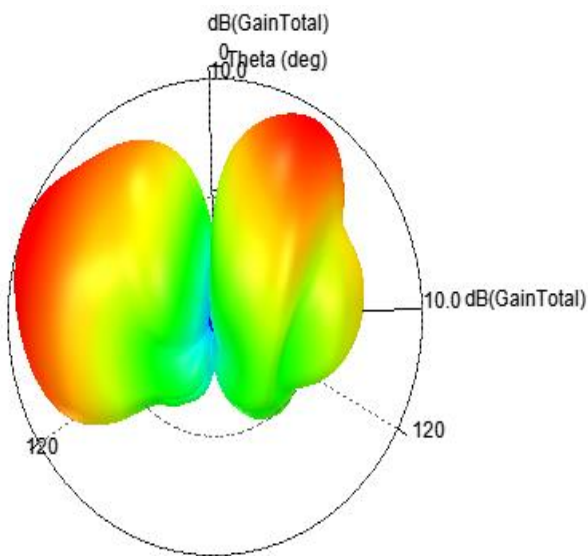

Fig 4(a). 3D Gain plot

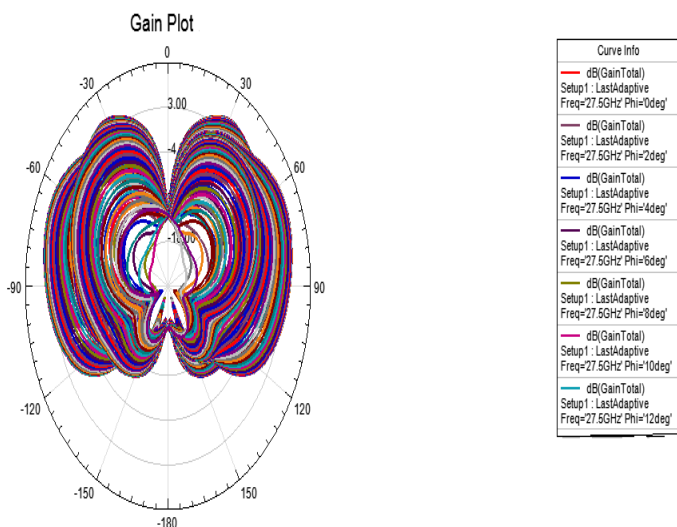

Fig 4(b). Gain plot

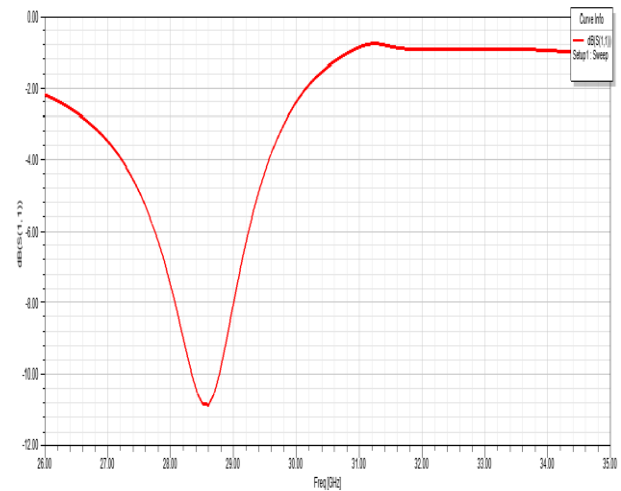

Fig 5. S Parameter values of linear array antenna

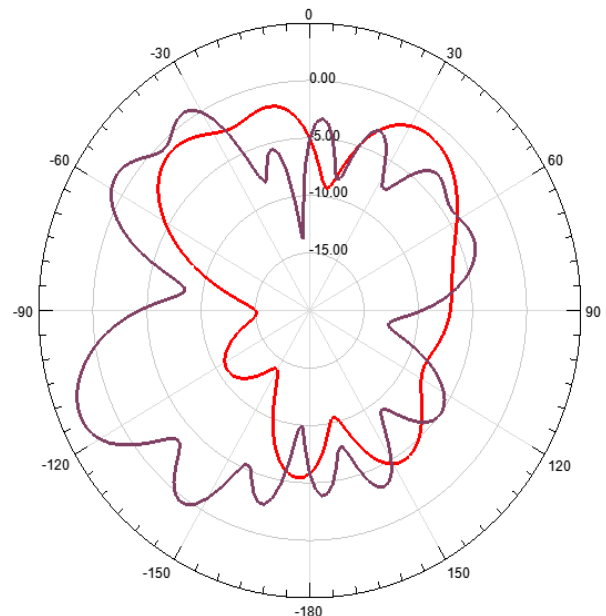

Fig 6(a). 2D gain plot

From Fig 7, SAR value obtained at the operating range of frequencies were measured. Which shows a acceptable position of the values, that too with in the allowable range of 1.6w/kg. The measured SAR value is 1.01w/kg

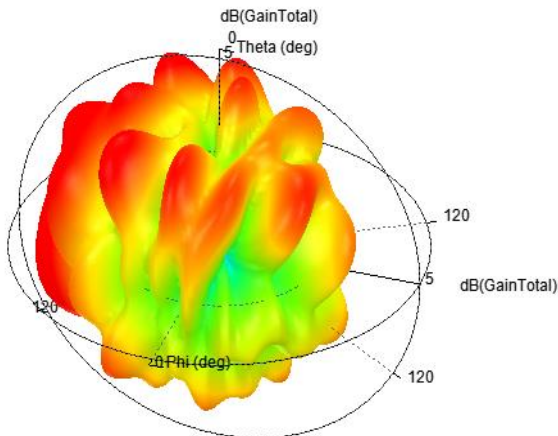

Fig 6(b). 3D gain plot

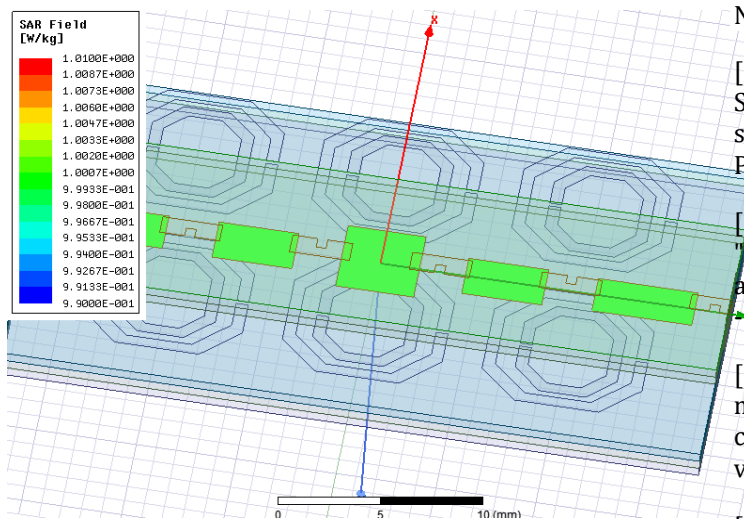

Fig 7. Simulation result of SAR value measurement

4. CONCLUSION

The design of a novel proximity coupled microstrip linear array antenna is proposed. The antenna operates from 27.5 GHz to 28.5 GHz with center frequency of 28 GHz. This will be very useful in applications where compact size is a major factor. In 5G communication mobile devices will get more importance and they should be capable of providing minimum safety to the user. In this instance this type of array antenna with reduced SAR value will get more attention as this provide low radiation towards human head. It may further be enhanced for phased array applications.

REFERENCES

[1]. L. Mall and R. Waterhouse, "Millimeter-wave proximity-coupled microstrip antenna on an extended hemispherical dielectric lens," IEEE Transactions on Antennas and Propagation , vol. 49, no. 12, pp. 1769 - 1772, 2001

[2]P. A. Dzagbletey and Y.-B. Jung, "Stacked Microstrip Linear Array for Millimeter-Wave 5G Baseband Communication," IEEE Antennas and Wireless Propagation Letters, vol. 17, no. 5, pp. 780 - 783, 2018.

[3] Henry Abu Diawuo and Young-Bae Jung, "Broadband Proximity Coupled Microstrip Planar Antenna Array for 5G Cellular Applications", IEEE Antennas and Wireless Propagation Letters,2018

[4] Hiroki Tsutsumi and Yoshihiko Kuwahara, "Design of the series fed microstrip patch planar array antenna by the parato genetic algorithm", IEEE International Symposium on Antennas and Propagation & USNC/URSI National Radio Science Meeting,2015

[5]. R. Asif, R.A. Abd-Alhameed, M Bin-Melha, A. Qureshi, C.H See, Y.I. Abdulraheem, TT Mapuka and J.M. Noras, "study on specific absorption rate", Loughborough Antennas and Propagation Conference (LAPC),2014.

[6].Y. Hayashi, K. Sakakibara, M. Nanjo and S. Sugawa, "Millimeter-Wave Microstrip Comb-Line Antenna," Antennas and Propagation, IEEE Transactions on, vol. 59, no. 2, pp. 398 -406 , December 2010

[7]H. A. Diawuo and Y. B. Jung, "Wideband proximity coupled microstrip linear array design for 5G mobile communication," Microwave and Optical Technology Letters, vol. 59, no. 12, pp. 2996-3002, 2017

[8] A. Safaai-Jazi, "A New Formulation for the Design of Chebyshev Arrays," Antennas and Propagation, IEEE Transactions on, vol. 42, no. 3, pp. 439-443, August 2002.

[9] Isaac B. T. da Silva, Humberto D. de Andrade, José L. da Silva," Effects of Complementary Split Ring Resonator (CSRR) Parameters in Microstrip Patch Antenna Characteristics", 2015 SBMO/IEEE MTT-S International Microwave and Optoelectronics Conference (IMOC