

# Performance Evaluation of DOA Estimation using MUSIC and Beamforming using LMS Algorithm for Static Scenario

<sup>1</sup>D. D. Khumane <sup>2</sup>Dr. S. M. Jagade

<sup>1</sup>Assitant Professor, Department of Electronics and Telecommunication Engineering, S.T.B. College of Engineering Tuljapur, Maharashtra India

<sup>1</sup>Principal, Department of Electronics and Telecommunication Engineering, S.T.B. College of Engineering Tuljapur, Maharashtra India

\*\*\*

**Abstract:** This paper presents a simulation study of a smart antenna (SA) system based on direction-of-arrival (DOA) estimation is based on the Multiple Signal Classification (MUSIC) algorithm for finding the Position Location (PL) of the desired user. The beamformer steer the main beam towards the desired user and nullify all other interferer, through adaptive beamforming using Least Mean Square (LMS) algorithm. This simulation results revealed the sharper peaks in the MUSIC angular spectrum and deep nulls in the LMS beam pattern. Also, this paper deals with DOA estimation and adaptive beamforming for the static case based on SA. Eigen decomposing fined the PL of the desired user using MUSIC algorithm and steer the beam toward this user using compute the weight vectors like Least Mean Square (LMS) algorithm.

**Key words** – Smart Antenna (SA), Beamformer, Direction-of-Arrival (DOA) Estimation, Multiple Single Classification (MUSIC), Least Mean Square (LMS), Signal Nulling.

## 1. INTRODUCTION

There is an ever increasing demand on mobile wireless operators to provide voice and high speed data services. At the same time, these operators want to support more users per base station to reduce overall network cost and make the services affordable to subscribers. As a result, wireless systems that enable higher data rates and higher capabilities are pressing need. Unfortunately because the available broadcast spectrum is limited, attempts to increase traffic within a fixed bandwidth create more interference in the system and degrade the signal quality. When omni-directional antennas are used at the base station, the transmission and reception of each users signal becomes a source of interference to other users located in the same cell, making the overall system interference limited.

The demand for wireless services has risen dramatically from few years. Wireless communication systems are evolving from the second generation systems to the third and fourth generation systems, which will provide high data rate multimedia services as video transmission. New value added services such as the position location (PL)

services for emerging calls, the fraud detection, intelligent transportation systems, and so fourth are also coming in to reality[1,2,3].

The smart antenna systems can generally be classified as either switched beam or adaptive array systems. In a switched beam systems can generally be classified as either switched beam or adaptive array systems. In a switched beam system multiple fixed beams in predetermined directions are used to serve the users. in this approach the base station switches between several beams that gives the best performance as the mobile user moves through he cell. Adaptive beam forming uses antenna arrays backed by strong signal process capability to automatically change the beam pattern in accordance with the changing signal environment. It not only directs maximum radiation in the direction of the desired mobile user but also introduces nulls at interfering directions while tracking the desired mobile user at the same time. The adaptation achieved by multiplying the incoming signal with complex weights and then summing them together to obtain the desired radiation pattern. These weights are computed adaptively to adapt to the changes in the signal environment. The complex weight computation based on different criteria and incorporated in the signal processor in the form of software algorithms like Least Mean Square. [7]

A smart antenna technology can achieve a number benefits like increase the system capacity, greatly reduce interference, increase power efficiency [4, 5]. In the following section, we implement the simulation study of DOA estimation using MUSIC algorithm and adapts the beam towards the desired user and nullify all other interference signal through LMS algorithm.

## 2. SYSTEM IMPLEMENTATION

The MUSIC, Multiple signal classification is a popular high resolution technique for estimating the DOA of multiple plane waves in noisy environment, using an array of multiple sensors. This algorithm involves Eigen decomposition of the covariance matrix derived from the input data model. The Eigen values of the covariance matrix are further divided into two sets called signal and

noise subspaces. The signal subspace consists of vectors correspond to signals received at an array and vectors of noise subspace are completely orthogonal to the signal subspace.

This algorithm can be summarized as, Estimate the spatial covariance matrix and compute the eigenvectors in signal and noise. After computing the eigenvectors find the steering vector, incoming signal vector and noise vectors.

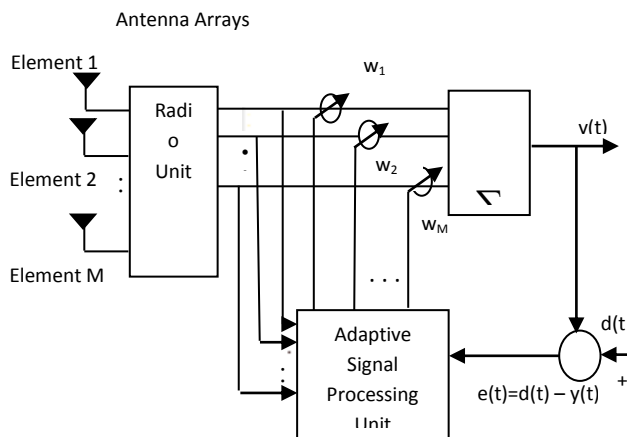

Fig.1. Smart Antenna System

Figure1, shows the LMS adaptive beamforming network, it consist of antenna arrays, signal processing unit, radio unit and adaptive weights. Consider a Uniform Linear Array (ULA) with  $M$  isotropic elements, which forms the integral part of the adaptive beamforming system as shown in the figure above. In short, the beam forming is done digitally, the beam forming and signal processing units normally be integrated in the same unit. For the DOA estimation and beamforming the antenna array and signal processing unit etc are the common.

### 3. SIMULATION AND RESULTS

As per reciprocity theory for radiation patterns, the received signals can be models as with reference to the data model equation

$$x(t) = A(\theta)s(t) + n(t) \tag{1}$$

Where,

- $A(\theta)$  = steering vector corresponding to signal direction.
- $s(t)$  = incident waves with the amplitude and phase in the azimuth plane
- $n(t)$  = Additive White Gaussian Noise (AWGN)

$$x(t) = \begin{bmatrix} x_1(t) \\ x_2(t) \\ \vdots \\ x_k(t) \\ \vdots \\ x_M(t) \end{bmatrix} = \begin{bmatrix} 1 \\ \vdots \\ e^{-j2\pi/\lambda(k-1)d \sin \theta} \\ \vdots \\ e^{-j2\pi/\lambda(M-1)d \sin \theta} \end{bmatrix} * \begin{bmatrix} s_1(t) \\ \vdots \\ s_k(t) \\ \vdots \\ s_M(t) \end{bmatrix} + \begin{bmatrix} n_1(t) \\ \vdots \\ n_k(t) \\ \vdots \\ n_M(t) \end{bmatrix} \tag{2}$$

Then the signal correlation matrix at the antenna output is  $R_{xx}$

$$R_{xx} = XX^H \tag{3}$$

Where 'X' is the data matrix, H denotes Hermitian Transpose. The Eigenstructure method, Multiple Signal Classification (MUSIC) algorithm are implement for direction source.

In short, by using this Eigen decomposing find the Position Location of the Desire user. To implement this, MUSIC algorithm is used.

If  $S_0$  is the steering vector associated with the desired signal of interest and  $S_i$  is the steering vector associated with interfering signal then

$$W^H S_0 = 1 \quad ; \text{ if user signal direction} \tag{4}$$

$$W^H S_i = 0 \quad ; \text{ if interferer} \tag{5}$$

$i = 1, 2, 3 \dots k$

And the output of the antenna array  $x(t)$  is given by,

$$x(t) = s(t)a(\theta_0) + \sum_{i=0}^{M_u} u_i(t)a(\theta_i) + n(t) \tag{6}$$

$s(t)$  denotes the desired signal arriving at angle  $\theta_0$  and  $u_i(t)$  denotes interfering signals arriving at angle of incidences  $\theta_i$  respectively.  $a(\theta_0)$  and  $a(\theta_i)$  represent the steering vectors for the desired signal and interfering signals respectively. Therefore it is required to construct the desired signal from the received signal amid the interfering signal and additional noise  $n(t)$

The LMS algorithm can be summarized in following equations.

$$\text{Output, } y(n) = w^h x(n) \tag{7}$$

$$\text{Error, } e(n) = d^*(n) - y(n) \tag{8}$$

$$\text{Weight, } w(n+1) = w(n) + \mu x(n)e^*(n) \tag{9}$$

The above data model, Eigenvector decomposition for Direction of Arrival Estimation using MUSIC algorithm and the parameters/results for beamforming through LMS algorithm has been simulated on MATLAB.

For this simulation, assign a different parameters and universal constants as

**Table-1:** Constants to be used for simulation

Parameter	Constant to be Assigned	Value
Speed of Light	C	$3 \times 10^8$ m/s
Signal to Noise Ratio (SNR)	SNR	20dB
Number of Elements in antenna array	M	6
Number of Time Steps	N	100,500 etc
Length of Time Step	dt	$1.0000 \times 10^{-4}$ (1E-4)
Number of Incoming Signals	L	5
Incoming Signal Frequency	$f_0$	$1 \times 10^9$ Hz (1E9)
Lambda	Lambda	$0.3000$ ( $c/f_0$ )
Step Size	$\mu_0$	0.02

around 20dB level below the maximum. In figure 4, the null steering beamformer in which the desired signal at an angle of 100 degree and all other interferer are nullify. The LMS error plot in fig.5 shows that the LMS algorithm converges. In this case the LMS error is almost 0.025 at around 500 samples.

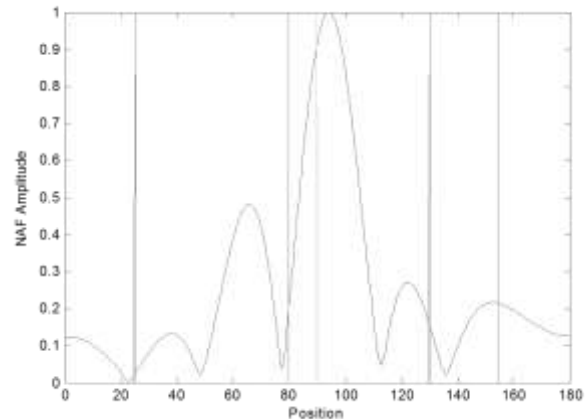

Fig 3. Position Location Vs Normalize Array Factor

And the simulation results on MATLAB are as:

Fig.2 shows the MUSIC spectrum for DOA Estimation, here the desired user at an angle of  $100^\circ$  and the four interferers at the different location at angle of 35, 65, 125 and 150 degree. And by using this simulation method, find the Position Location (PL) of the desired user.

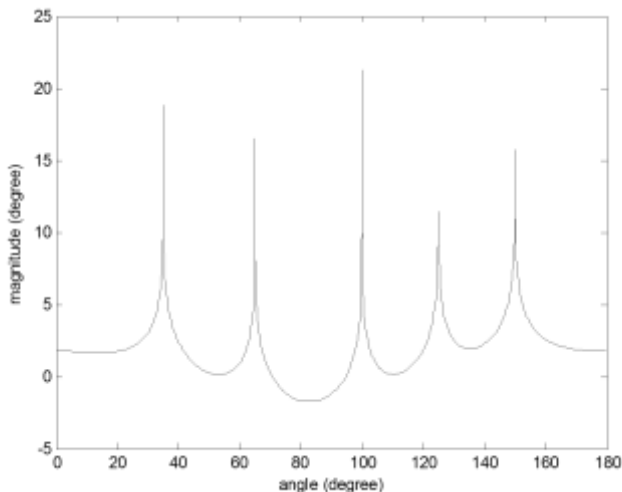

Fig. 2 Angle of Arrival Vs Magnitude in Degree (MUSIC)

Here the desired angle is arriving at 100 degrees and there are four interfering signals arriving at angles 65, 35, 125 and 150 degrees respectively. The array factor plot in Fig.3 shows that the LMS algorithm is able to iteratively update the weights to force deep nulls at the direction of the interferers and achieve maximum in the direction of the desired signal. It can be seen that nulls are deep at

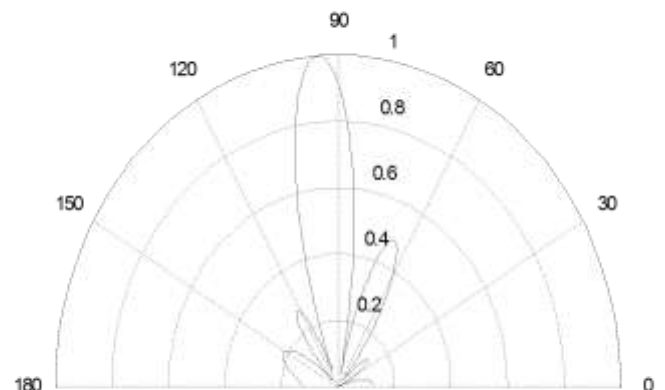

Fig 4. Null Steering Beamformer

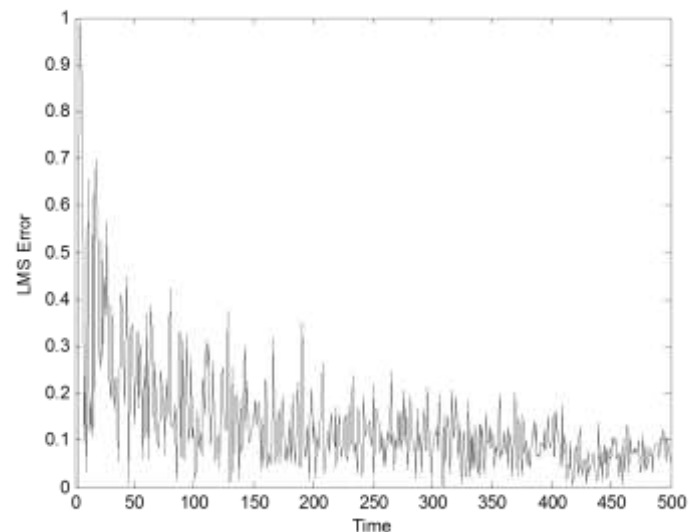

Fig. 5 Samples (Time) Vs Least Mean Square Error

#### 4. CONCLUSIONS

Here the simulation for the DOA estimation, compute a spatial spectrum then estimate DOA's using MUSIC algorithm. These methods apply weights to each element in the array so as to steer the antenna pattern towards a known look direction. And the capability to resolve multiple targets with separation angles smaller the main lobe beam width of the array. Once a DOA is estimated, the beamformer adapts the antenna pattern to steer the main beam towards the desired user and place nulls in the unwanted direction through LMS algorithm.

It is easy to identify the transfer function of the unknown system, also its ability to perform in a system, which is heavily corrupted with noise and the stability of its results.

#### REFERENCES

1. T.S. Rappaport, J.H. Reed and B.D. Woerner, "Position location using wireless communications on highways of the future," IEEE Communications Magazine, vol. 34, no.10, pp. 33-41, 1996.
2. G.V. Tsoulos, "Smart antennas for mobile communication systems: benefits and challenges," IEEE Electronic & Communication Engineering Journal, Vol 11, no.2 pp. 84-94, 1999.
3. K.J. Krizman, T.E. Biedka, and T.S. Rappaport, "Wireless Position location: fundamentals, implementation strategies, and sources of error," in Proc. IEEE Vehicular Technology Conference, Vol 2 pp. 919-923, Phoenix, Ariz, USA, MAY 1997.
4. Tsoulos G.V. Meach MA. Swalas S.C. Adaptive Antennas for Third Generation DS-CDMA Cellular Systems, Proceedings of the 45<sup>th</sup> Vehicular Technology Conference, Vol 1, pp. 45-49, July 1995.
5. Okamoto G.T. Smart Antennas and Wireless LANS. Kluwer Academic Publishers, Norwell Mass., 2002
6. Godara, L.C., Application of Antenna Arrays to Mobile Communications, Part II: Beamforming and Direction-of Arrival Considerations, Proceedings of the IEEE, Vol. 85, No. 8 pp 1195-1245, August 1997.
7. Ch. Santhi Rani, P.V. Subbaiah, K. Chennakesava and S. Sudha Rani, "LMS and RLS Algorithms for Smart Antennas in a W-CDMA Mobile Communication Environment," ARPN Journal of Engineering and Applied Sciences" Vol. 4, no.6, August 2009.