

# THERMODYNAMIC ANALYSIS AND OPTIMIZATION OF OFFSET STRIP FIN PLATE HEAT EXCHANGER

MALIK SADIK KHAN<sup>1</sup>, SUDHANSHU MISHRA<sup>2</sup>

<sup>1</sup>Department of Mechanical Engineering, SSTC- SSEC- Bhilai, Chhattisgarh, India

<sup>2</sup>Asst. Professor, Department of Mechanical Engineering, SSTC- SSEC -Bhilai, Chhattisgarh, India

\*\*\*

**Abstract** - The objective of the present study is to evaluate thermodynamic performance analysis of parallel flow plate fin HE with offset strip fins. The hot side fluid stream is taken as water and cold side fluid stream is air for the analysis. The analysis is based on thermodynamic, performance evaluation via using software MATLAB and ANOVA-TM with suitable develop programming codes and runs. Furthermore optimization have been done and presented to reduce of number of test runs by using Design of Experiment (DOE) and finding the design parameters which is having or delivers optimal efficiency. The heat exchanger (main) parameters which is taken as variable are given as: Fin Space (S) from 1.80 – 2.35 mm, Fin Height (H) from 6.8 – 9.8 mm, Fin Thickness (t) from 0.1 – 0.2 mm, Fin Length (l) from 3.5 – 9.0 mm, Alpha ( $\alpha = 0.183-0.338$ ), Beta ( $\beta = 0.02 - 0.04$ ), Gamma ( $\gamma = 4.5 - 13.0$ ), Delta ( $\delta = 0.071-0.111$ ), Frontal air velocity ( $V = 0 - 19$  m/s) and Reynolds number (Re) from 500-7500. To analysis Colburn factor (j) and the friction factor (f) previous developed correlations have been used, which is developed and reported on the literature by the authors on the basis of their experimental results.

**Key Words:** Heat Exchanger (HE), plate fin heat exchanger (PFHE), Design of Experiment (DOE), Offset strip fin heat exchanger, Optimization

## 1. INTRODUCTION

Heat exchangers have kept important role found popular in the different process industries. It is used for the transfer and exchange the heat between two fluids (fluids can be same or can be different) [1-2].

### 1.1 Plate Fin Heat Exchangers

Plate fin heat exchangers (PFHE) and tube-fin are widely employed in different industries like Automobile, Aerospace, Chemical, Petro-chemical, Air separation, Helium, Hydrogen liquefiers, Gas & oil processing, Radiators, Air Conditioners, and in Aircrafts etc. In recent times efforts are made in India, towards the progress and construction of small & compact HE for various industry applications [1-6].

## 1.2. Offset Strip Fin HE

This fin geometry has been most widely used geometry, especially in high performance plate fin heat exchangers. It consists of a type of interrupted surface, which may be visualized as a set of plain fins having cut normal to the direction of stream flow with regular intervals.

Into offset strip fins, each segment being offset laterally by half the fin spacing as shown in Fig. 1.

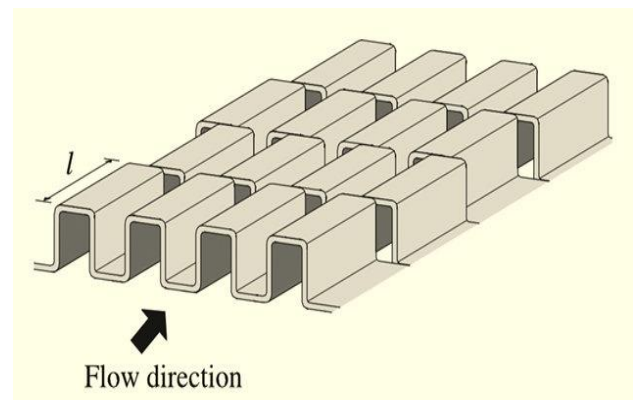

Fig.1. Offset Strip fins.

## 2. OBJECTIVES OF THE STUDY

Overall objectives of present analysis are as given in point wise as in below:

1. Thermodynamic analysis for offset strip plate fin heat exchanger.
2. To analyse the effective performance parameters of present HE in terms of performance parameters i.e. heat transfer and pressure drop. Furthermore validations of present analysis have also been carried out.
3. Optimization of the different geometrical and operating parameters of present work in order to reduce the number of simulation runs by using Design of Experiment (DOE).
4. To present the set of optimal parameters, who delivers maximum effectiveness for present investigated offset strip plate fin heat exchanger.

### 3. DESIGN OF EXPERIMENTS (DOE)

The optimization of the any system process is a difficult task owing to the having many variable variables.

Design of Experiments (DOE) provides an efficient and systematic way in order to optimize system designs for performance, quality, and cost [7-8].

#### 3.1. Signal to Noise Ratio (S/N ratio)

Taguchi created a transform function for the loss-function which is named as signal -to-noise (S/N) ratio [9-11]. The S/N ratio, as described earlier, is a concurrent statistic.

The equation for calculating S/N ratios for “Smaller is better” (SB), “Larger is better” (LB) and “Nominal is best” (NB) types of characteristics are as follows Eq. 1 to 3. [7-10].

1. Larger the better:

$$\frac{S}{N} = -10 \log \left( \frac{1}{n} \sum \frac{1}{Y^2} \right) \quad (1)$$

2. Lower the better:

$$\frac{S}{N} = -10 \log \left( \frac{1}{n} \sum Y^2 \right) \quad (2)$$

3. Nominal the best:

$$\frac{S}{N} = -10 \log \left( \frac{1}{n} \sum \bar{Y}^2 \right) \quad (3)$$

### 4. HEAT TRANSFER EVALUATION FOR H.E.

The heat transfer is expressed (for air side) in terms of Colburn factor (j) [11]:

$$j = 0.101 \text{Re}^{-0.189} \alpha^{-0.488} \beta^{0.479} \delta^{-0.297} \gamma^{-0.315} \quad (4)$$

Where  $\alpha, \beta, \delta, \gamma$  are non-dimensional parameters which is given and well described in Nomenclature section

Nusselt number (Nu) can be expressed in terms of Colburn factor (j)

$$j = \frac{Nu}{\text{Re.Pr}^{1/3}} \quad (5)$$

The air is treated as incompressible fluid, and the density of air is treated as constant according to air temperature (for present analysis):

Pressure drop ( $\Delta P$ ) and friction factors (f) for present analysis (for Offset strip fin HE, for air side) expressed as [11]:

$$f = 2.092 \text{Re}^{-0.281} \alpha^{-0.739} \beta^{0.972} \delta^{-0.78} \gamma^{-0.497} \quad (6)$$

And

$$\Delta p = \frac{4fLG^2}{2D_h \rho} \quad (7)$$

Where

$$D_h = \frac{4A_c}{P} \quad (8)$$

Reynolds number is expressed as

$$\text{Re} = \frac{GD_h}{\mu} \quad (9)$$

#### 4.1. Raw input data for present analysis

**Table -1:** Different design and operating parameters for offset strip fin plate HE used for the present investigation.

Parameters and Symbol	Range	Unit
Fin Space (S)	1.80 - 2.35	mm
Fin Height (H)	6.8 - 9.8	mm
Fin Thickness (t)	0.1 - 0.2	mm
Fin Length (l)	3.5 - 9.0	mm
Fin material (Aluminum)	--	--

$\alpha$ , Non dimensional parameter	0.183 - 0.338	--
$\beta$ , Non dimensional parameter	0.02 - 0.04	--
$\gamma$ , Non dimensional parameter	4.5 - 13.0	--
$\delta$ , Non dimensional parameter	0.071 - 0.111	--
Duct Dimension	270 x 220	mm
Frontal air velocity	0 - 19	m/s
Reynolds number (Re) (for air side)	500-7500	Dimensionless

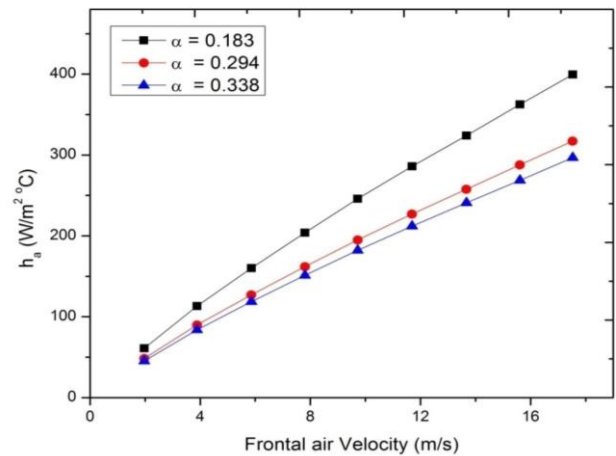

Fig.3 Heat transfer coefficient (h) versus frontal air velocity (V) with different values of alpha (α).

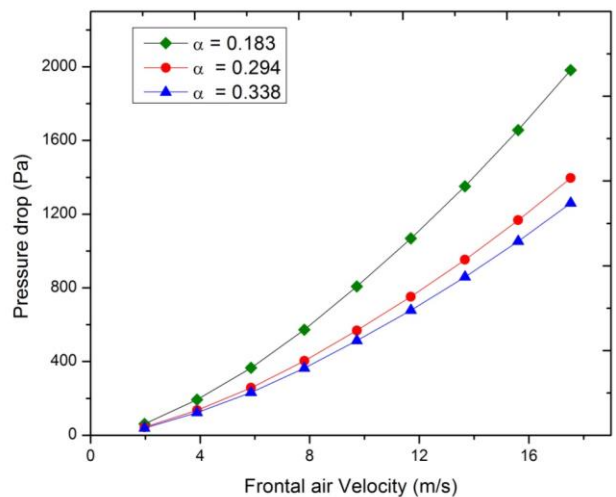
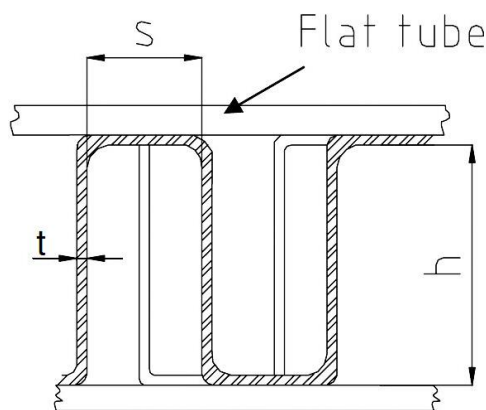
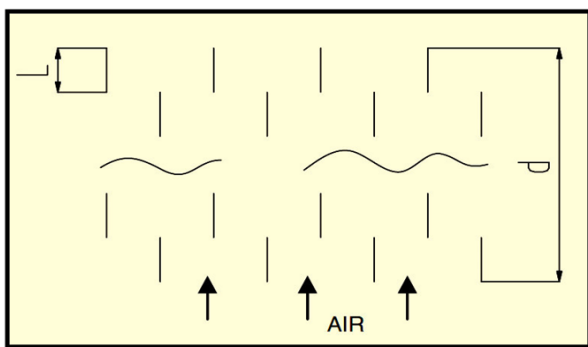

Fig.4. Pressure drop (ΔP) versus frontal air velocity (V) with different values of alpha (α).

Fig.2. Various geometrical parameter of offset strip fin HE and its details consider for present analysis.

4.2. Effect of Offset Strip Fin Parameters on H.E.

4.3. The effect of alpha

The effect of fin parameter alpha (α) which is the ratio of fin space (S) to the fin height (H) i.e. (S/H) on the average heat transfer coefficient (h) and pressure drop in the present HE are shown in Figs. 3 and 4 respectively.

From the Figs. 3 and 4, it can be seen that with the increase the values of (V) the heat transfer coefficient (h) and pressure drop in HE of air side increases for all values of (α).

But increasing the values of alpha (α) from 0.183 to 0.338 there is reduction in numerical values of heat transfer coefficient (h) and pressure drop of offset strip fin plate HE.

5. PLAN FOR THE OPTIMIZATION

With the above analysis we have to obtain the geometrical, operating parameters of HE that delivers balanced performance between these 2 performance parameters i.e. higher heat transfer and the minimum friction factor (pressure drop).

### 5.1. Factors and Levels

In present work, 4 design parameters as input parameters namely Alpha, Beta, Delta and Gamma along with lower (V= 1.97 m/s) and higher (V= 17.52 m/s) values of mass velocities have been considered which have been used during analysis.

All 4 parameters, with their assigned codes and assigned 3- levels are given in below Table - 2.

**Table – 2:** Design parameters of a three-level DOE method.

Design Parameters	Code	Level - 1	Level - 2	Level - 3
$\alpha$ , Non dimensional parameter	A	0.183	0.294	0.338
$\beta$ , Non dimensional parameter	B	0.02	0.03	0.04
$\delta$ , Non dimensional parameter	C	0.071	0.098	0.111
$\gamma$ , Non dimensional parameter	D	4.5	10.6	14.3

Table - 3. Shows the overview about effects of each, Fin parameters (design parameter) with mass velocity on, heat transfer coefficient (h) and pressure drop ( $\Delta P$ ).

**Table – 3:** Test plan of  $L_{27} (3^4)$  with heat transfer coefficient (h) and pressure drop ( $\Delta P$ )

Run No	Frontal Air Velocity (m/s)	Fin Parameters for H.E.				h (W/m <sup>2</sup> k)	$\Delta P$ (Pa)
		A	B	C	D		
1	1.97	0.183	0.02	0.071	4.5	61	61.5
2		0.294	0.03	0.098	4.5	48.2	43.2
3		0.338	0.04	0.111	4.5	45.2	39.2
4	17.52	0.183	0.02	0.071	4.5	399.6	1981.8
5		0.294	0.03	0.098	4.5	317.1	1396.2
6		0.338	0.04	0.111	4.5	296.8	1259.4
7	1.97	0.183	0.02	0.071	4.5	61	61.5
8		0.183	0.02	0.071	4.5	74.1	91.2

9	17.52	0.183	0.04	0.071	4.5	85	120.6
10		0.183	0.02	0.071	4.5	399.6	1981.8
11		0.183	0.03	0.071	4.5	485.3	2939.4
12	1.97	0.183	0.04	0.071	4.5	557	3887.6
13		0.183	0.02	0.071	4.5	61	87.2
14		0.183	0.03	0.098	4.5	55.4	67.8
15	17.52	0.183	0.02	0.111	4.5	53.4	61.5
16		0.183	0.03	0.071	4.5	399.6	2810.4
17		0.183	0.04	0.098	4.5	636.2	2125.8
18	1.97	0.183	0.02	0.111	4.5	349.9	1981.8
19		0.183	0.03	0.071	4.5	55.4	67.8
20		0.183	0.04	0.071	10.6	42.3	44.3
21	17.52	0.183	0.02	0.071	14.3	38.5	38.2
22		0.183	0.03	0.071	4.5	363.1	2185.7
23		0.183	0.04	0.071	10.6	277.2	1427.8
24	3.8	0.183	0.02	0.071	14.3	252.4	1230.4
25		0.183	0.03	0.071	4.5	113.2	192.8
26		0.294	0.02	0.071	4.5	89.8	135.8
27	17.52	0.338	0.02	0.071	4.5	83.9	122.5
28		0.338	0.03	0.071	4.5	83.9	122.5

Fig.5. shows the effect of the SN Ratio of each design parameter (A, B, C, D) which have been considered for heat transfer coefficient. For this factor i.e. heat transfer coefficient “Larger is Better” criterion has been selected. This means that the largest SN ratio level of all the levels for each factor has the best performance.

From Fig. 5 we can observe that heat transfer coefficient have been increases up to 2<sup>nd</sup> level for design factors A, B and C after that it all goes to down.

Furthermore it can also be seen from this Fig. that design factors D have continuous increasing SN R behaviour for all the 3 Levels.





## 6. CONCLUSIONS

In this study, the effects of the various kinds of design parameters of fin on heat transfer and pressure drop characteristics of the offset strip fin heat exchanger have been studied with DOE method.

The analyses have been performed for 9 different mass velocities from 1.9 - 17.52, than total 108 runs have been performed for heat transfer (9\*No of levels for each factors\*Total number of fin parameters of fin i.e.  $9 \times 3 \times 4 = 108$ ). Similarly 108 test runs have also been performed for pressure drop.

The main conclusions from this study are as follows:

1) The optimal parameters of present HE have been designed  $L_{27} (3^4)$  to maximize the heat transfer and minimize the pressure drop with offset strip fins.

The selected parameters for design of heat exchanger are mass velocity, different fin geometry parameters i.e. alpha ( $\alpha$ ), beta ( $\beta$ ), delta ( $\delta$ ) and gamma ( $\gamma$ ).

2) The effect of these particular parameters on heat transfer enhancement was evaluated and it can be concluded that a HE with offset strip fins should be operated for ( $\alpha = 0.294$ ), ( $\beta = 0.03$ ), ( $\delta = 0.098$ ) and ( $\gamma = 14.3$ ).

3) To obtain minimum pressure drop from present HE, it should have and operated for fin parameters having values as ( $\alpha = 0.294$ ), ( $\beta = 0.03$ ), ( $\delta = 0.098$ ) and ( $\gamma = 14.3$ ).

4) Factor Delta have highest contribution ratio 45.41 % for heat transfer and 43.1 % for pressure drop in present HE.

Finally, after obtaining the most effective parameters of the HE performance, an effective design is obtained by changing or reducing the number of test runs from 216 to 27 and after that 27 to 2 for heat transfer and pressure drop.

## REFERENCES

- [1] Wang L, Sundén B, Manglik RM. Plate heat exchangers: design, applications and performance. Southampton, UK: WIT Press; 2007.
- [2] Kakac, S., Bergles, A.E., Mayinger, F. Heat Exchangers, Thermal-Hydraulic Fundamentals and Design, by Hemisphere Publication, 1980.
- [3] W.M. Kays, A.L. London, Compact Heat Exchangers, McGraw-Hill, New York, 1984.
- [4] T.L. Bergman, F.P. Incropera, Fundamentals of Heat and Mass Transfer, John Wiley & Sons, 2011.
- [5] J.P. Holman, Experimental Methods for Engineers, McGraw-Hill, New York, 1984.
- [6] W.M. Kays, The basic heat transfer and flow friction characteristics of six compact high-performance heat transfer surfaces, Journal of Energy Power, 1960, 27–34.
- [7] R.N. Kackar, Off-line quality control, parameter design and the Taguchi method, Journal of Quality Technology 17 (1985) 176–188.
- [8] G. Taguchi, System of Experiment Design, Quality Resources, International Publications, New York, 1987.
- [9] M.S. Phadke, Quality Engineering Using Robust Design, Prentice-Hall, NJ, 1989, p. 334.
- [10] Ross, P.J. Taguchi Techniques for Quality Engineering; McGraw-Hill: New York, 1998.
- [11] Junqi Dong , Jiangping Chen , Zhijiu Chen , Yimin Zhou, Air-side thermal hydraulic performance of offset strip fin aluminum heat exchangers. Applied Thermal Engineering. 27 2007, 306–313.