

Design and Performance Analysis of Thermoelectric Conversion Module for Waste Heat Recovery

Shubham J. Chotia¹, Swapnil M. Bhale²

^{1,2}B.E. student Department of Mechanical Engineering, V.C.E.T. Vasai Road, Maharashtra, India.

Abstract - The conventional pie shaped TEG is way too rigid in construction and is inefficient for usage on cylindrical heat source. The objective revolves around the nascent development of a Thermoelectric Tube which would overcome the shortcomings of conventional TEG. The Thermoelectric Tube works on Transverse Thermoelectric Effect and operates in analogy with shell and tube type heat exchanger. The structure of Thermoelectric Tube is flexible enough to recover heat from cylindrical heat source. Computational analysis on conventional TEG was performed and verification of the same was done by experimentation. Same boundary condition were used for computational analysis of proposed Thermoelectric Tube for benchmarking it. Through computational analysis it was found that conventional TEG produced 0.0034 W of power when hot side temperature was maintained at 300 °C and cold side temperature at 33 °C, whereas the Thermoelectric Tube made of alternate Ni- Bi₂Te₃ outperformed conventional TEG generating 1.69 W of power for same boundary conditions. Further analysis of Thermoelectric Tube for different material combination showed that using Ni (Nickel) as p-type material produced the maximum output and using any other material would result in almost zero output.

Key Words: Thermoelectric Tube, Thermoelectric Generator (TEG), Seeback Effect, Peltier Effect, Seeback Coefficient, Figure of Merit, ANSYS, Off Diagonal Thermoelectric Effect.

1. INTRODUCTION

The electricity generated by solar and wind facilities are currently the most common sources of renewable energy which greatly depending on time of the day and weather conditions. This make them inefficient to use. Geothermal and industrial flue or exhaust gasses are a stable source of heat and can be used to extract power. The thermoelectric conversion module that converts heat directly into electrical power, is partially well regarded as an environmentally friendly electricity generation technology with no moving parts (as in case of turbines) and no carbon dioxide emission.

The π shaped thermoelectric generator has a block-like or plate-like configuration without flexibility, the TEG cannot be flexibly attached to heat sources having various circular or curved surfaces. Moreover, when multiple TEG are attached to heat sources having various shapes, for

example, heat source having a cylindrical shape, the overall surface in contact of the thermoelectric conversion material with the heat source is not complete and uniform and thus a lot of heat is been wasted to the surrounding which can be used to produce electricity. Thus the efficiency of the waste heat utilisation is reduced and hence the overall efficiency of the unit reduces.

The objective of the report is to provide a design and theoretical analysis of new thermoelectric conversion module which can be efficiently used as waste heat recovery system. We have designed and presented in the report a thermoelectric module of tilted multi-layered structured. The efficiency and power development capacity of the tube made of tilted multi-layered structure varies as the combination of the material used. In this report we have used Bismuth and Nickel as our first combination and shown the result of the theoretical analysis. The thermoelectric tube allows the hot fluid to flow inside and operates in analogy with the standard shell and tube heat exchanger. Thus the thermoelectric tube serves as power generator and a heat exchanger within a single unit.

2. THEORITICAL EVALUATION OF THERMOELECTRIC MODULE AND EXPERIMENTAL SETUP

2.1 Concept and Schematic drawing

Thermoelectric tube works on the principle of transverse thermoelectric effect which is also known as off diagonal thermoelectric effect which is essentially developed in tilted layer material. Thermoelectric tube is assembly of alternate rings of thermoelectric material and a pure metal which can be manufactured using powder Metallurgy and crystal growth techniques. The thermoelectric tube can generate electricity by running hot fluid inside the tube and impressing itself in cold fluid.

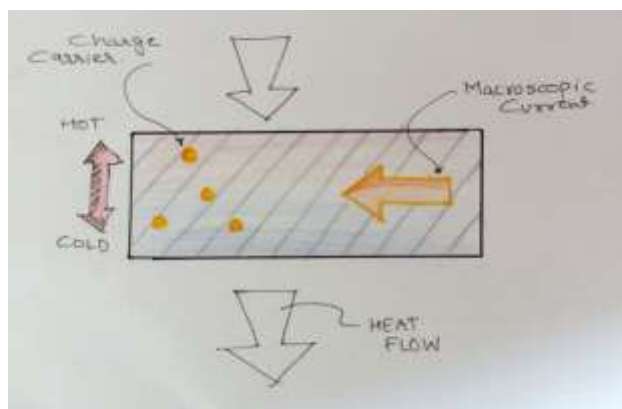

Figure1. Schematic Diagram of Transverse TE (ODTE) effect in Tilted Layer Material

The principle working of this thermoelectric tube is that when the heat is flowing radially outward the current generated will flow in axial direction.

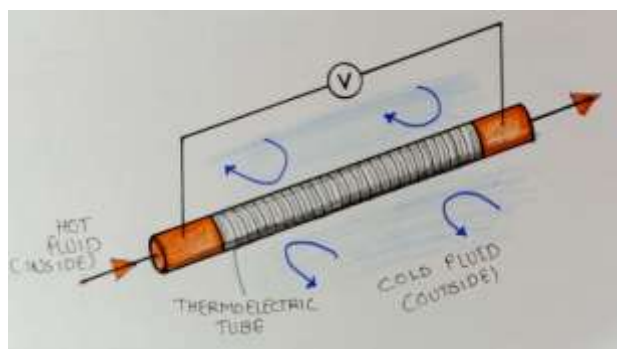

Figure 2. Schematic diagram of the Operation of the TE tube, Temperature Difference along the Radial direction generating Electric Signal along Axial Direction.

2.2 Construction of the setup

According to the operational conditions required and used for the analysis of our thermoelectric module, the experimental setup is so constructed that the same conditions are obtained. A 150cc IC engine is used. The exhaust gas temperature of the engine is 400 to 900 degree Celsius, which is exactly the same range that we have considered for our analysis. The exhaust manifold is modified and a tube of the same dimensions as that of our module is constructed and fitted in the manifold. The material used for the tube is Mild Carbon Steel. Four Thermoelectric generators that are normally used in the market are to be used which will be fixed so as to cover the tube completely covering maximum surface area possible. The four thermoelectric generators are connected together to the breadboard so that their collective readings are obtained. The connections are made to the multimeter so as to get the readings. Two thermocouples are fitted in the setup. One thermocouple is fitted at the surface of the tube and the second thermocouple is fitted at the middle of the tube. The

output of the thermocouple is obtained on a display. A water jacket is placed surrounding the thermoelectric generator. The exhaust gasses are then allowed to flow out into the atmosphere from the tube. This is the complete experimental setup for our project.

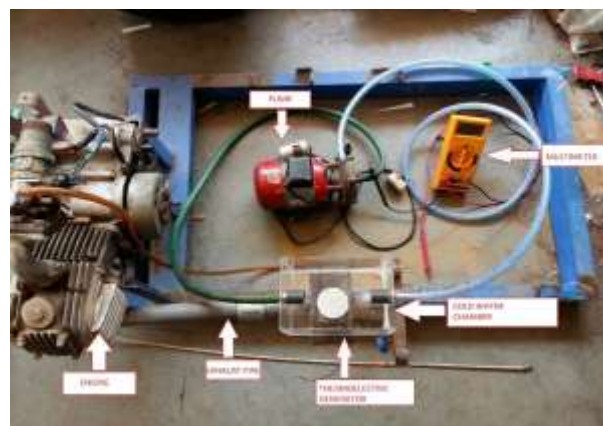

Figure 3. The Experimental Setup for the TEG performance Readings

2.3 Working of the setup

The running engine provides an exhaust gas temperature in the range of 400 - 900 C. The exhaust gasses flow through the exhaust manifold and through the designed tube. The thermoelectric properties of a material is widely dependent on the temperature difference between the modules. The interior of the tube has the temperature equal to the temperature of the exhaust gas. The outside temperature of the tube is lesser than the interior temperature. The water jacket placed surrounding the thermoelectric generator adds on to increase the temperature difference and thus the heat flow. Thereby increasing the electricity produced. The temperatures at the interior and the exterior of the tube is measured using the thermocouples. The output of the thermoelectric generator is measured using the multimeter. The resistance can also be measured across the bulb that can be connected in series for getting the values. Finally the exhaust gasses are then allowed to escape in the atmosphere. The readings practically observed in this experimental setup is to be compared with the readings obtained by the analysis of our module design.

2.4 Input data for design of the system

Off-Diagonal thermoelectric effect is typically appears in multilayer with alternate stacks of dissimilar materials such as a thermoelectric and a pure metal. The macroscopic properties of these thermoelectric/metal multilayers are highly anisotropic between layer parallel and perpendicular directions due to considerable difference in its thermoelectric parameters:

$$S_{perp} \gg S_{||} \gg, \rho_{perp} \gg \rho_{||}, K_{perp} \gg K_{||}$$

We have observed high thermal and electrical conductivity nearly as high as pure metal in parallel direction and low conductivity in perpendicular direction.

Multilayer structure Bi – Ni – Bi consist of stack of layers of materials Bi & Ni. The thermoelectric properties of the multilayer in the layers parallel and perpendicular direction are given by Kirchoff's law, which is given by:

$$S_{||} = \frac{\frac{STE + Sm}{PTE + Pm}(Tr)}{\frac{1}{PTE + Pm} + \frac{P}{PTE + Pm}}$$

$$S_{\perp} = \frac{STE * Km + (Tr) * Sm * KTE}{(Tr) KTE + Km}$$

$$\rho_{||} = \frac{PTE * Pm (1 - P)}{p * PTE + Km} \quad \rho_{\perp} = \frac{PTE + Pm}{1 + Tr}$$

$$K_{||} = \frac{KTE + Km * (Tr)}{(Tr) + 1} \quad K_{\perp} = \frac{KTE * Km (1 + Tr)}{(Tr) KTE + Km}$$

$$Tr = \text{Thickness ratio} = \frac{tTE}{tm}$$

The thermoelectric parameters in tilted multilayer structure are theoretically formulated by a transport tensor.

$$\begin{bmatrix} T_{xx} & T_{xz} \\ T_{zx} & T_{zz} \end{bmatrix} = \begin{bmatrix} T_{11} \cos^2 \theta + T_{\perp} \sin^2 \theta & \frac{1}{2} (T_{11} - T_{\perp}) \sin 2\theta \\ \frac{1}{2} (T_{11} - T_{\perp}) \sin 2\theta & T_{11} \sin^2 \theta + T_{\perp} \cos^2 \theta \end{bmatrix} \quad (3.1)$$

In ODTE effect, the figure of merit is described as:

$$Z_{zx} * T = \frac{S_{zx}^2 * T}{K_{zz} * P_{xx}}$$

The thermoelectric properties in the multilayer can be optimized by varying the tilt angle (θ) and combination of dissimilar material, which is the different optimizing way.

Table 1. Material Properties

Material	T(K)	S(μV/K)	ρ (Ωm)	K (Wm ⁻¹ K ⁻¹)
Bi _{0.5} Sb _{1.5} Te ₃	300	210	1.2 x10 ⁻⁵	1.10
PbTe	700	236	2.2 x10 ⁻⁵	1.44
Sb _{0.2} Ge _{0.8}	1000	232	2.48 x10 ⁻⁵	2.56
Bi	300	-110	1.05 x10 ⁻⁶	8.20
Pb	300	-1.05	2.13 x10 ⁻⁷	35.3
In	300	1.68	8.4 x10 ⁻⁸	83.7

Sn	300	-1.00	1.05 x10 ⁻⁷	62.5
Al	300	-1.66	2.62 x10 ⁻⁸	247
Ni	300	-20	1.7 x10 ⁻⁸	51
	700	-25.8	1.7 x10 ⁻⁷	72.2
	1000	-29.9	4.2 x10 ⁻⁷	71.2
Cu	300	1.83	1.67 x10 ⁻⁸	400
	700	2.83	3.83 x10 ⁻⁸	372.5
	1000	5.36	7.92 x10 ⁻⁸	357
Ag	300	1.51	1.63 x10 ⁻⁸	429
	700	2.82	4.82 x10 ⁻⁸	404
	1000	7.95	6.52 x10 ⁻⁸	379
Au	300	1.94	2.01 x10 ⁻⁸	317
	700	2.86	5.82 x10 ⁻⁸	291
	1000	3.85	8.85 x10 ⁻⁸	270

In this paper we are theoretically demonstrating the ODTE effect of thermoelectric tube. For the purpose of calculation we are taking the first combination i.e. Bi_{0.5}Sb_{1.5}Te₃ and N.

Assuming thickness ratio (Tr) =1

Substituting in Kirchoff's relations

$$S_{||} = -1.678 \times 10^{-5} = -16.78 \mu\text{V/k}$$

$$S_{\perp} = 204.1 \mu\text{V/k}$$

$$K_{||} = 26.05 \text{ (W/mK)}$$

$$\rho_{||} = 3.352 \times 10^{-7} \text{ (}\Omega\text{m)}$$

$$\rho_{\perp} = 6.085 \times 10^{-6} \text{ (}\Omega\text{m)}$$

From Equation no. 1

$$S_{zx} = \frac{1}{2} (S_{||} - S_{\perp}) \sin 2\theta = 1.1044 \times 10^{-4} \sin 2\theta$$

$$K_{zz} = K_{||} \sin^2 \theta + K_{\perp} \cos^2 \theta = 26.05 \sin^2 \theta + 2.1535 \cos^2 \theta$$

$$\rho_{xx} = \rho_{||} \cos^2 \theta + \rho_{\perp} \sin^2 \theta = 3.352 \times 10^{-7} \cos^2 \theta + 6.085 \times 10^{-6} \sin^2 \theta$$

Calculating above TE parameters for the tilt angle range from (0-90)

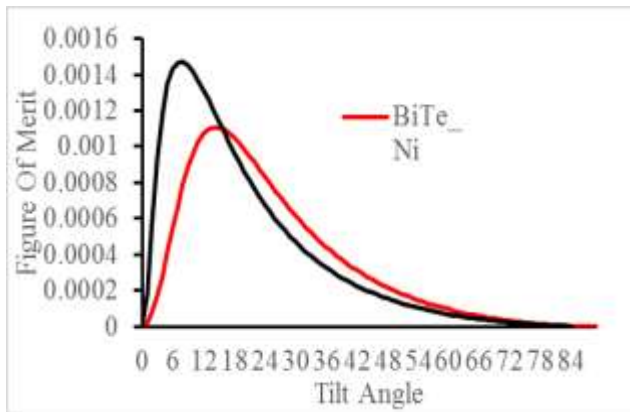

Figure 4. Figure of Merit vs. Tilt Angle

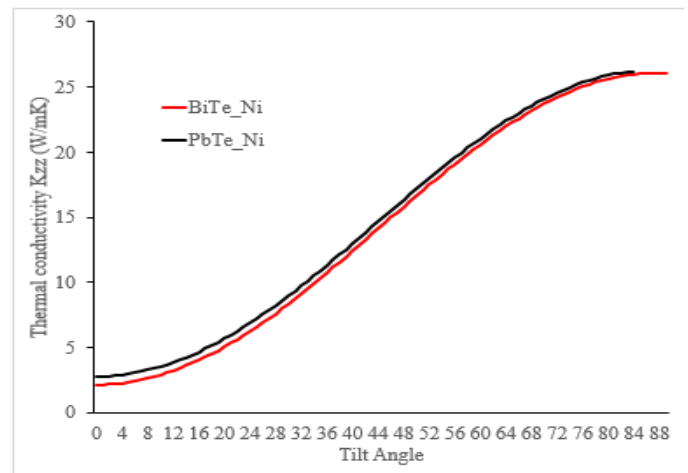

Figure 7. Thermal Conductivity Kzz vs. Tilt Angle

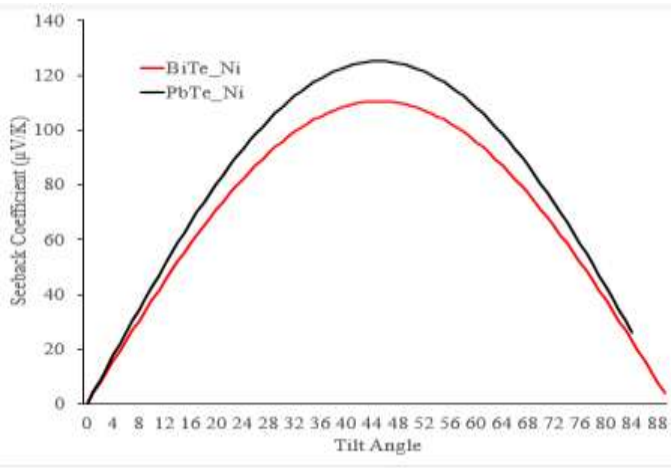

Figure 5. Seeback Coefficient vs. Tilt Angle

As the efficiency of thermoelectric is function of figure of merit higher the figure of merit higher is the efficiency. Selecting tilt angle $\theta = 15^\circ$

$$S_{zx} = 55.22 \text{ (}\mu\text{V/k)} \quad Z_{zx} = 0.001107$$

Resistance of tube can be calculated by

$$R = \frac{\rho_{xx} \cdot L}{A} \quad L = \text{length of tube} \quad A = \text{Area of c/s}$$

Assuming sample thermoelectric tube length 12 cm

Outer diameter = 14 mm inner diameter = 12 mm

At $\theta = 15^\circ$

$$\rho_{xx} = 7.204 \times 10^{-7} \text{ }\Omega\text{m}$$

$$A = \frac{\pi}{2} (14 \times 14 - 10 \times 10) = 75.39821 \text{ m}^2$$

$$A = 7.53982 \times 10^{-5} \text{ m}^2$$

$$L = 12 \text{ cm} = 0.12 \text{ m}$$

$$R = 1.1465 \text{ m}\Omega$$

Voltage generated by transverse seeback effect

$$V_x = S_{zx} \cdot \Delta T$$

$$V_x = 55.2 \times 10^{-5} \Delta T$$

Assuming the operation temp or temp fuel gases from exhaust of SI engine range from 400 to 900 c.

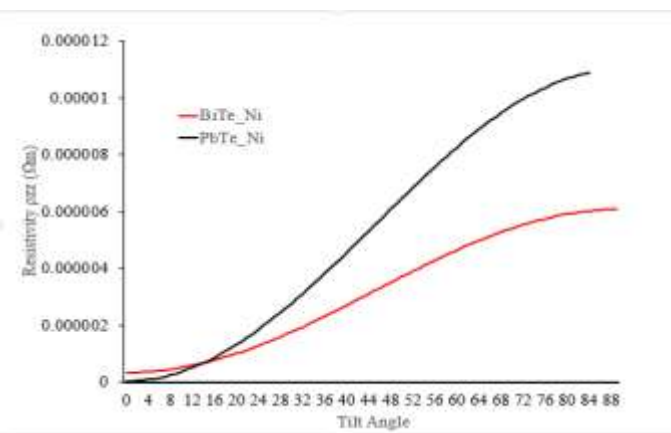

Figure 6. Resistivity ρ_{zz} vs. Tilt angle

Theoretically deriving the voltage generation with temp difference assuming the outside temp fix 30° C.

Efficiency or performance of tube

$$\eta = \frac{p}{q} \quad ; p = \text{power output, } q = \text{heat transfer rate}$$

At maximum power output efficiency can be simplified to

$$\eta = \frac{\Delta T}{\frac{4}{Z_{xx}} + 2Th - \frac{\Delta T}{2}} \quad ; \Delta T = \text{Temperature difference,}$$

Th = Temperature of flue gases

Assuming minimum flue gas temp Th = 400k

$$\Delta T = 400 \quad Z_{xx} = 0.001107$$

$$\eta = \frac{400}{\frac{4}{0.001107} + 2 \times 430 - 200} = 9.362\%$$

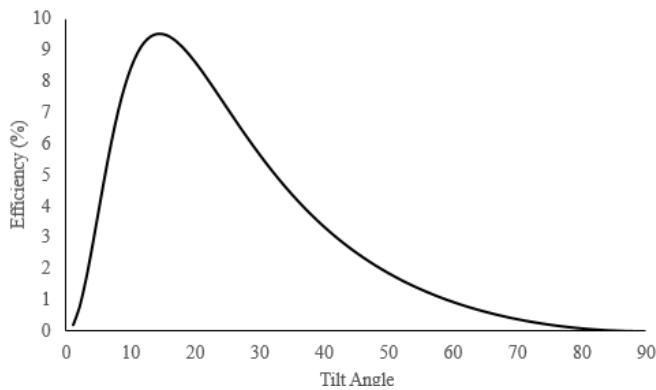

Figure 8. Efficiency vs. Tilt angle

2.5 Design of Thermoelectric tube

Engine specification.

Type:- Air cooled, 4 stroke cylinder OHC, self-start.

Bore x stroke = 52.4mm x 57.8mm

Displacement = 124.7 cc

Compression ratio = 9.1:1

Maximum power = 6.72 Kw at 7000 rpm

Maximum torque = 10.35 kW

$$\eta_v = \frac{\text{actual volume of air taken in}}{\text{swept volume}}$$

$$0.8 = \frac{\text{actual volume of air}}{124.7}$$

Actual volume of air = 99.76 cc = 9.976 x 10⁻⁵ m³/s

Stoichiometric ratio for given compression ratio is 14.7:1

Assuming approximate best bsfc = 0.35 Kg/kWh.

$$\text{bsfc} = \frac{\text{mass flow rate of fuel}}{\text{brake power}} = \frac{\text{mass flow rate of fuel}}{6.72} = \frac{0.35}{1000 \times 3600}$$

Mass flow rate of fuel = 6.572 x 10⁻⁴ Kg/s

Heat input = mass flow rate x calorific value

Assuming CV = 48000 kJ/kg

Heat input = 31.546 KW.

Assuming P1 = 1 bar and T1 = 27°C $\frac{V1}{V2} = 9.1$

$$\frac{T1}{T2} = \left(\frac{V1}{V2}\right)^{1.4-1} = 9.1^{1.4-1}$$

T2 = 725.667 K

Heat input = m x CV x (T3 - T2)

31.546 = 0.717 (mass flow rate of air + mass flow rate fuel) x (T3 - T2)

T3 = 5875.24 K

Work output = (area under 3-4) - (area under 2-1)

Indicated power = $\frac{m \times R}{1.4-1} \times \{(T3 - T2) - (T2 - T1)\}$

Indicated power = 28.958 Kw

Heat rejected = indicated power - heat input

Heat rejected = 2587.419 W

Heat rejected = mass flow rate of fuel x (1+AFR) x CV x (T4 - T1)

T4 = 722.37 K

Mass flow rate of exhaust = 6.572 x 10⁻⁴ x (1 + air fuel ratio) = 8.543 x 10⁻³ kg/s

$$V1 - V2 = \text{swept volume} \times \frac{\text{speed}}{2 \times 60}$$

V1 = 8.16 x 10⁻³ m³

$$PV = m R T$$

$$\text{Exhaust pressure} = P_4 = 2.17 \text{ bar}$$

$$\text{Exhaust temperature} = 722.37 \text{ K} = 449 \text{ }^\circ\text{C}$$

$$\text{Mass flow rate} = 8.544 \times 10^{-3} \text{ kg/s}$$

$$\text{Velocity of gas leaving cylinder} = v_1 = \text{stroke length} \times \text{strokes per minute}$$

$$\text{Assuming the strokes per min} = 7000$$

$$\text{Velocity of gas leaving cylinder} = \frac{57.8 \times 7000}{1000 \times 60} = 6.743 \text{ m/s}$$

$$\text{Bore diameter} = 52.4 \text{ mm}$$

$$A_1 = \text{bore area} = 2156.5 \text{ mm}^2$$

$$\text{Exhaust pipe diameter} = 30 \text{ mm}$$

$$A_2 = \text{exhaust pipe area} = 706.8 \text{ mm}^2$$

By continuity equation

$$A_1 \times V_1 = A_2 \times V_2$$

$$\text{Velocity of exhaust gas} = 20.57 \text{ m/s}$$

Assuming TEMA - H type shell and tube heat exchanger (counter flow).

Selecting Standard size inlet tube and outlet tube size for cold fluid.

$$d = 25.4$$

$$A = \frac{\pi}{4} \times 0.0254^2 = 5.067 \times 10^{-4} \text{ m}^2$$

$$\text{Specific heat of flue gases} = 1 \text{ KJ/kg}$$

$$C_{ph} = 1 \text{ KJ/kg}$$

$$\text{Specific heat of cold fluid (water)} = 4.182 \text{ KJ/kg}$$

$$C_{pc} = 4.187 \text{ KJ/kg}$$

$$\text{Mass flow rate of hot gas} = 8.544 \times 10^{-3} \text{ KJ/s}$$

$$\text{Mass flow rate of cold water} = \rho_w V_w A$$

$$\text{Assuming } V_w = 1 \text{ m/s}$$

$$\rho_w = 1000 \text{ kg/m}^3$$

$$A = 5.067 \times 10^{-4} \text{ m}^2$$

$$m_c = 1000 \times 1 \times 5.067 \times 10^{-4}$$

$$= 0.5067 \text{ kg/s}$$

Assuming inlet temperature of cold fluid = 27°C

$$T_{c1} = 27 + 273 = 300 \text{ K}$$

$$\text{Performance of tube } \eta = \frac{P}{Q}$$

At maximum power output

$$\eta = \frac{\Delta T}{\frac{4}{2xx} + 2Th - \frac{\Delta T}{2}}$$

$$T_h = 723 \text{ K}$$

$$T_c = 300 \text{ K}$$

$$\Delta T = 423 \text{ K}$$

$$\eta = 8.72 \%$$

Consider unaccounted heat loss actual heat at thermoelectric tube can be assumed to be 1500 W

$$Q = m_h C_{ph} (T_{h1} - T_{h2}) = m_c C_{pc} (T_{c2} - T_{c1})$$

$$\frac{1500}{8.544 \times 10^{-3} \times 1000} = 723 - T_{h2}$$

$$T_{h2} = 547.4 \text{ K}$$

$$\frac{1500}{80.5067 \times 4.187 \times 1000} = T_{c2} - T_{c1}$$

$$T_{c2} = 300.707 \text{ K}$$

$$\theta_1 = T_{h1} - T_{c2} = 422.293 \text{ K}$$

$$\theta_2 = T_{h2} - T_{c1} = 247.4 \text{ K}$$

$$\text{LMTD} = \theta_m = \frac{\theta_1 - \theta_2}{\ln\left(\frac{\theta_1}{\theta_2}\right)}$$

$$Q = UA\theta_m$$

Assuming thin walled tube $U = 13.1 \text{ W/m}^2\text{K}$

$$A = 0.35 \text{ m}^2$$

Assuming standard outer diameter $D_o = 25.4$ (Handbook)

And number of tubes = 3

$$A = n\pi D_o L$$

$$L = 146 \text{ mm}$$

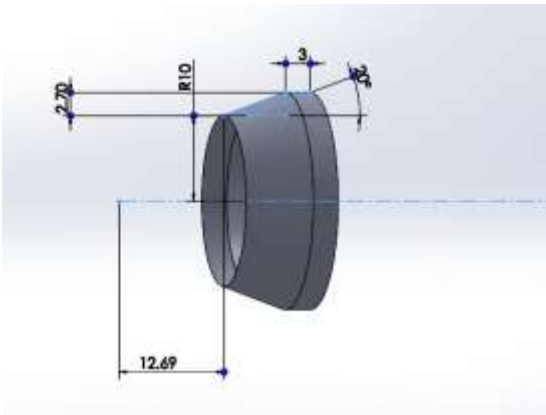

Figure 9. P & N type Rings



Figure 11. Assembly of a Single Tube

Total Length of the Tube – 146 mm

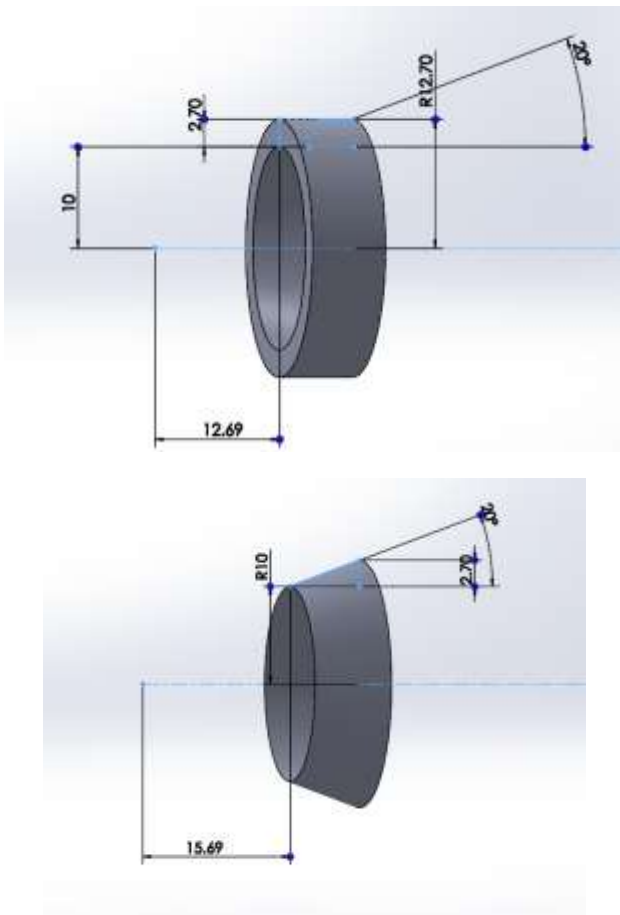

Figure 10. End Rings of Copper Material

Smaller Diameter – 20 mm

Bigger Diameter – 25 mm

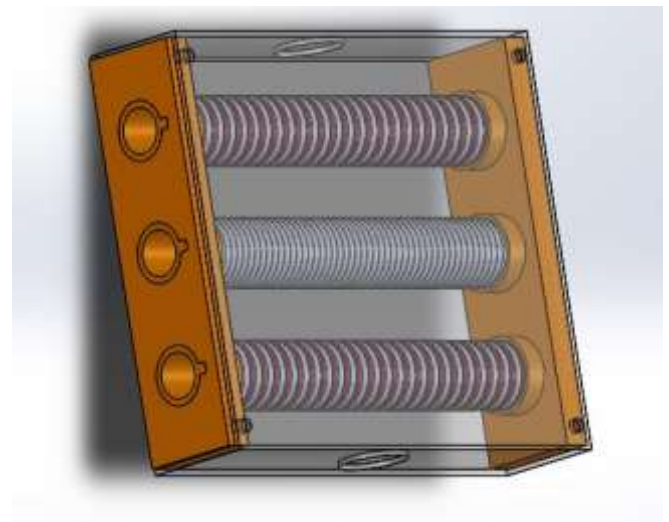

Figure 12. CAD Model Assembly of the Module

3. COMPUTATIONAL ANALYSIS OF THERMOELECTRIC TUBE & THERMOELECTRIC GENERATOR (TEG)

The thermo-electric and structural analysis of thermoelectric tube is carried out using ANSYS AIM and ANSYS workbench 18.2.

Following results are obtain from ANSYS workbench analysis:

- Temperature variation
- Voltage generated
- Current density

Operating conditions

- Exhaust Pressure = 2.17 bar

- Exhaust Temperature = 449°C
- Mass flow rate = 8.54e-3 kg/sec
- Exhaust gas Velocity = 9.7 m/sec

Steady State thermoelectric analysis

Boundary conditions

Hot Side Fluid domain

Temperature range = 50 to 500 °C

Cold Side Fluid domain

Temperature range = 30 to 80 °C

Convection: Simplified water case with coefficient = 1200 W/K

Temperature 30 to 80 °C

Voltage potential = 0 V

Material combination used for the purpose of analysis.

Table 2. Materials Selected for Analysis

Material	Seeback Coefficient V/K	Resistivity ohm-m	Thermal Conductivity W/mK
Bi0.5Sb1.5Te3	210e-6	1.2e-5	1.10
PbTe	236e-6	2.2e-5	1.44
Sb0.2Ge0.8	232e-6	2.48e-5	2.56
Ni	-20e-6	1.7e-8	51
Al	-1.66e-6	2.62e-8	247
Ag	2.82e-6	4.82e-8	404

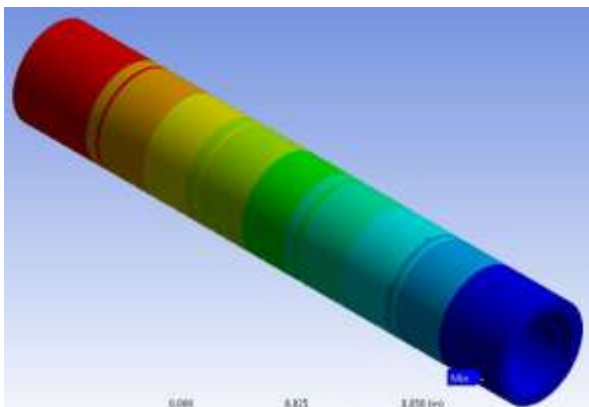

Figure 13. Voltage Generated in Thermoelectric Tube ANSYS Analysis

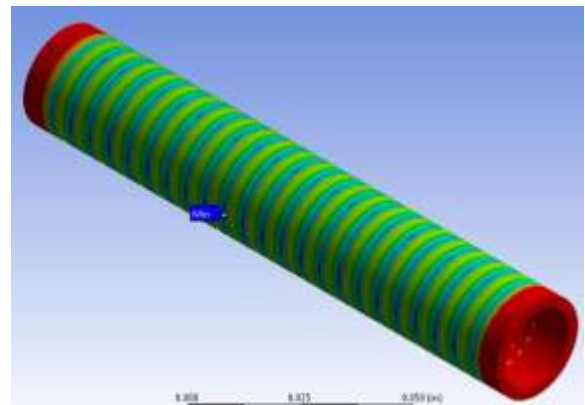

Figure 14. Temperature variation in Thermoelectric Tube ANSYS Analysis

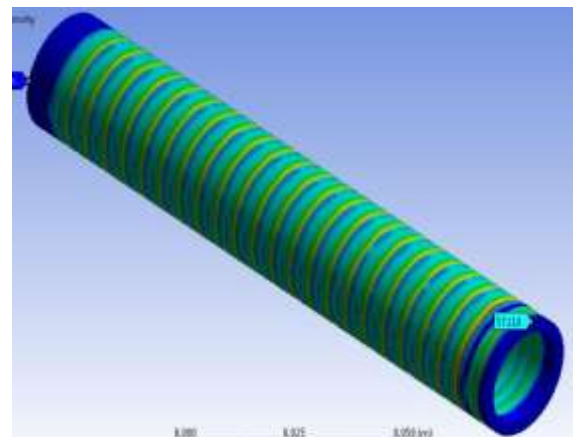

Figure 15. Current flow in Thermoelectric Tube ANSYS Analysis

Static structural analysis Loads
Temperature load from steady state thermoelectric system
exhaust pressure = 2.17 bar

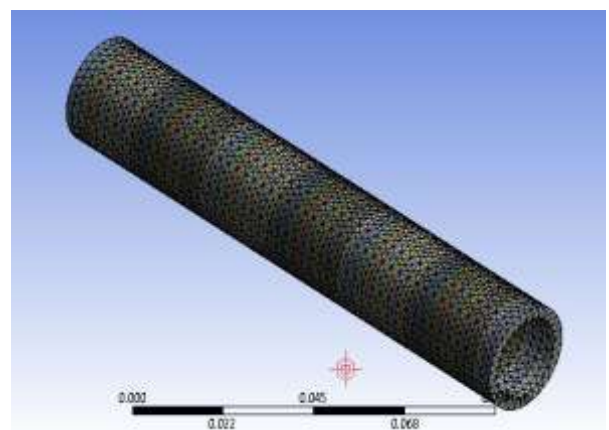

Figure 16. Thermoelectric Tube in mesh

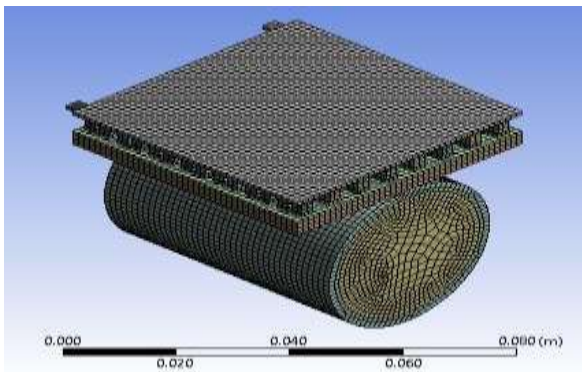

Figure 17. Thermoelectric Generator Assembly in mesh

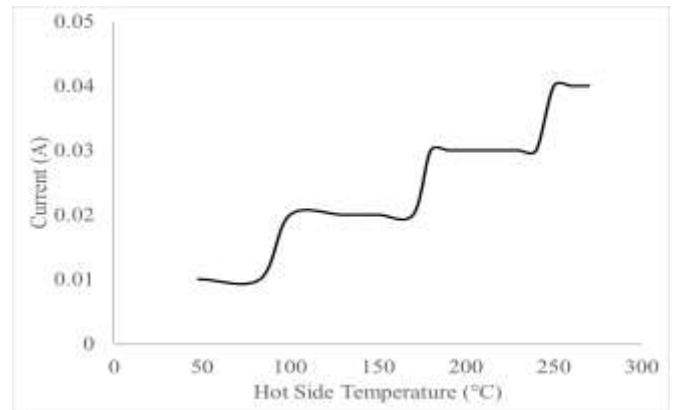

Figure 20. Current (A) Vs Hot Gas Temperature (°C) of TEG from Experimental Setup

At 300°C the current obtained was 0.04 A

4. RESULTS AND CONCLUSION

Thermoelectric Generator (TEG) Experimental Graphs

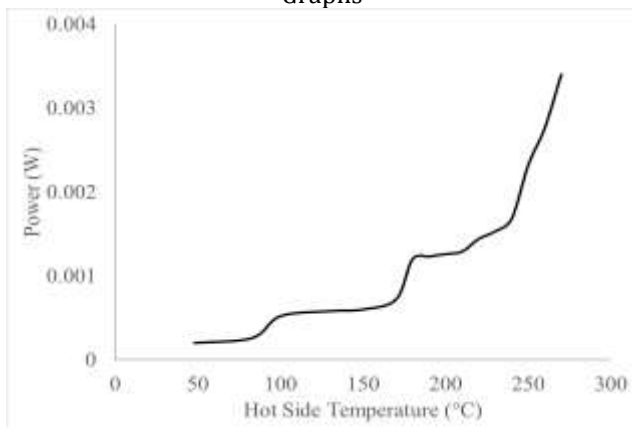

Figure 18. Power (W) Vs Hot Gas Temperature (°C) of TEG from Experimental Setup

Experimentally at 300°C the maximum power output was 0.0034watts

Analysis Graphs of Thermoelectric Tube on ANSYS Workbench

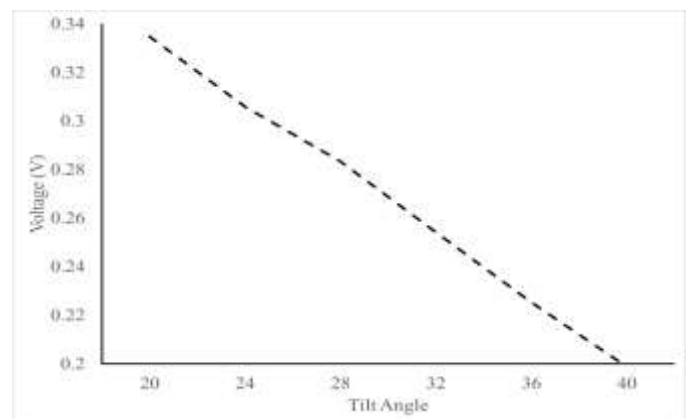

Figure 21. Voltage (V) Vs Tilt Angle (deg) of Thermoelectric Tube from ANSYS analysis

At tilt angle 24° the voltage is 0.31 V

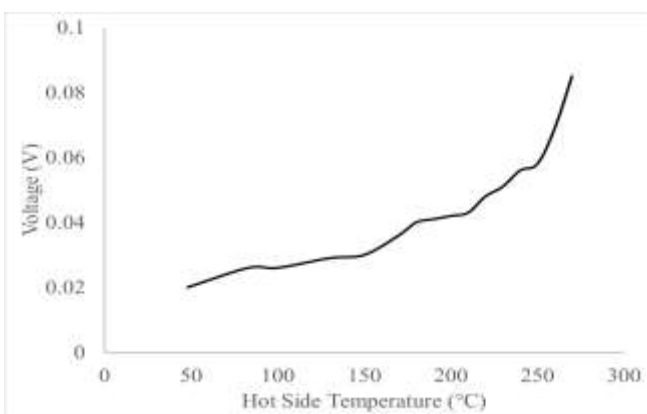

Figure 19. Voltage (V) Vs Hot Gas Temperature (°C) of TEG from Experimental Setup

At 300°C the voltage obtained was 0.09 V

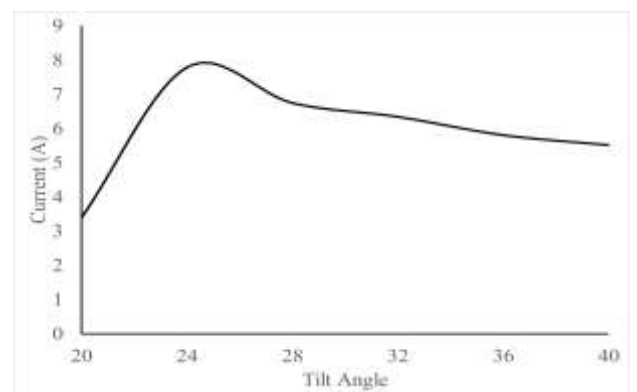

Figure 22. Current (A) Vs Tilt Angle (deg) of Thermoelectric Tube from ANSYS analysis

At tilt angle 24° the voltage obtained is 7.8 V

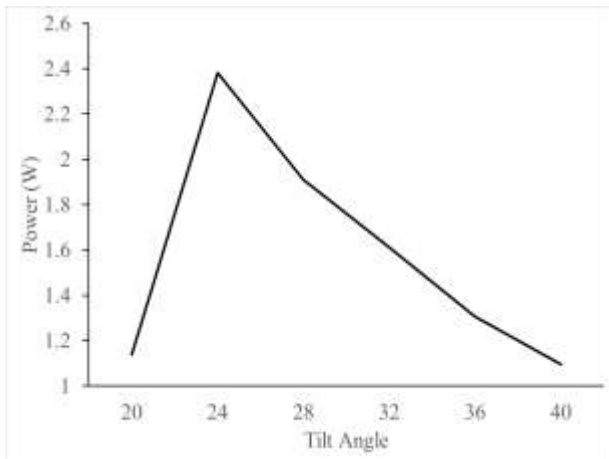

Figure 23. Power (W) Vs Tilt Angle (deg) of Thermoelectric Tube from ANSYS analysis

At tilt angle 24° the voltage obtained is 2.4 V

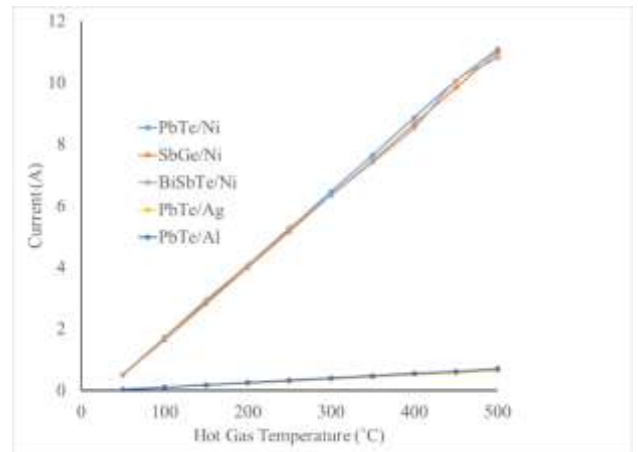

Figure 26. Current (A) Vs Hot Gas Temperature (°C) of $Bi_{0.5}Sb_{1.5}Te_3/Ni$ Thermoelectric Tube from ANSYS analysis

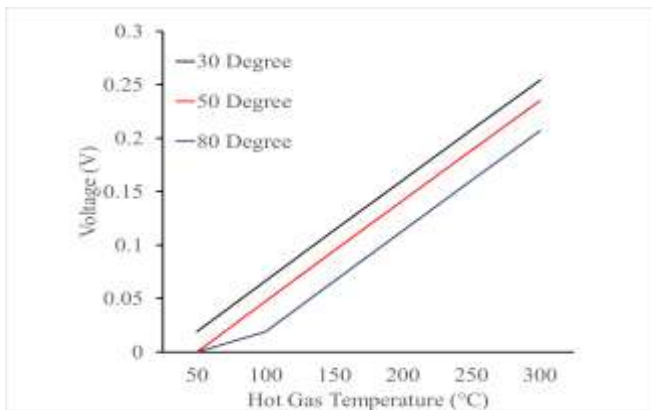

Figure 24. Voltage (V) Vs Hot Gas Temperature (°C) of $Bi_{0.5}Sb_{1.5}Te_3/Ni$ Thermoelectric Tube from ANSYS analysis

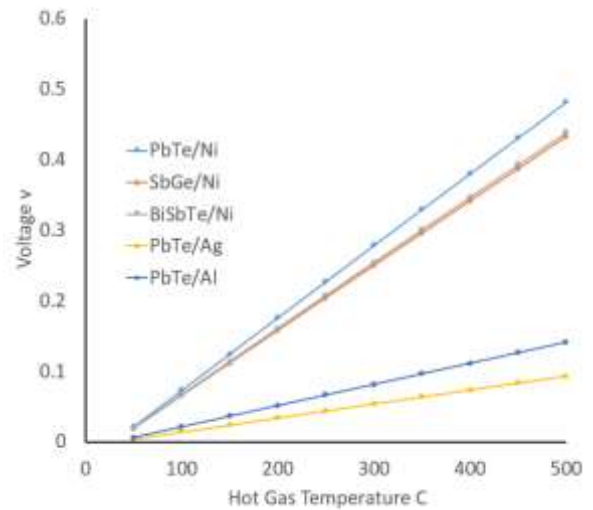

Figure 27. Voltage (V) Vs Hot Gas Temperature (°C) of $Bi_{0.5}Sb_{1.5}Te_3/Ni$ Thermoelectric Tube from ANSYS analysis

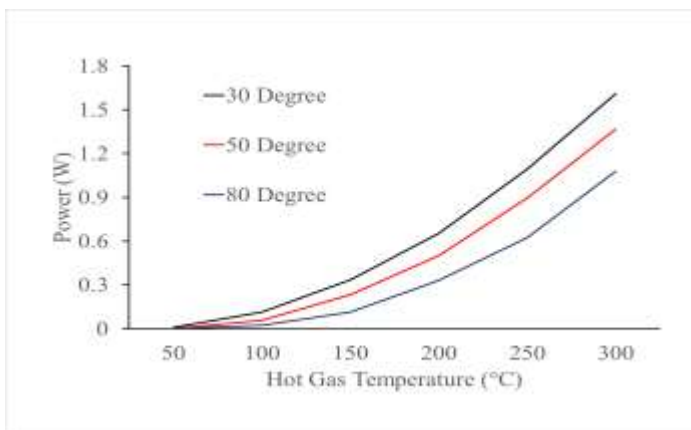

Figure 25. Power (P) Vs Hot Gas Temperature (°C) of $Bi_{0.5}Sb_{1.5}Te_3/Ni$ Thermoelectric Tube from ANSYS analysis

At 300°C the power obtained was 1.61 W

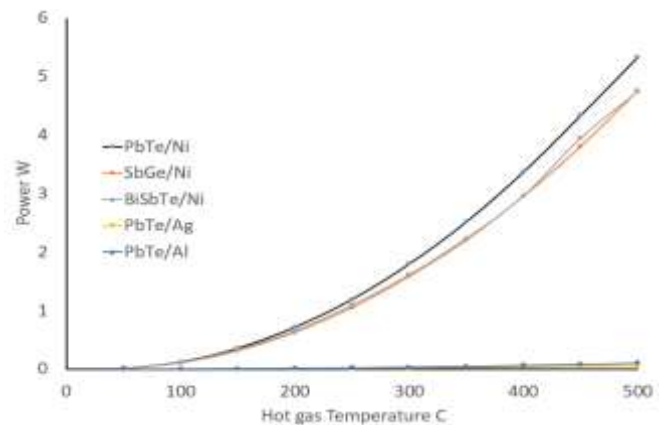

Figure 28. Power (W) Vs Hot Gas Temperature (°C) of $Bi_{0.5}Sb_{1.5}Te_3/Ni$ Thermoelectric Tube from ANSYS analysis

Power at 300°C for different material

Material	Power (W)
PbTe/Ni	= 6.457
SbGe/Ni	= 6.349
Bi0.5Sb1.5Te3/Ni	= 6.337
PbTe/Ag	= 0.3746
PbTe/Al	= 0.408

Summary of results obtained

- The power generated by Thermoelectric Generator is 0.0034W and Thermoelectric Tube is 1.69W at 300°C.
- From graph in Fig 6.11 among the two promising materials (PbTe/Ni and Sb0.2Ge0.8) PbTe/Ni was found more efficient generating 5.33 W at 500 °C hot gas temperature.
- From graph in Fig.6.6 at 24° tilt angle maximum power of 2.38 W was obtained at 300°C.
- From Fig.6.8 the power generation by the thermoelectric tube increases as the temperature difference between hot side and cold side increases.
- From Fig 3.9 and 6.11 theoretically the power generated by the tube is 5.89W but the 1.69W is obtained at 300 °C from analysis on ANSYS.
- Al, Ag and Au cannot be used as p-type material in thermoelectric tube as the power generated by this materials is about 0.1W.
- Thermoelectric tube can be used as power generator and heat exchanger tube in one unit.

5. CONCLUSION

In thermoelectric tube the tubular structure enables direct heat transfer from hot fluid to thermoelectric material and also high thermal conductivity of pure metal layer reduces the resistance of tube. The thermoelectric tube made up of tilted TE/metal achieves perfect balance between high power generation and efficient heat exchange.

The power obtained experimentally by the thermoelectric generator at 300 °C is 0.0038 W. And the power generated by the thermoelectric tube at 300 °C analytically is 1.69W. The output with different material combinations is checked, and the best output obtained is with Lead

Telluride and Nickel. It is also found that other metals like Silver and Aluminium cannot be used to replace Nickel.

The practical application of such TE tube still encounters numerous issues. One of the major concern is durability of the tube, since the electric current is exposed fluid, the electric corrosion can hamper the performance of TE tube and the impurities present in the fluid domain can result in the fouling of the tube which reduce the performance of the tube. Also as the material used in thermoelectric tube are toxic a thin surface coating on its surface is mandatory.

6. REFERENCES

1. B. Orr a,* , A. Akbarzadeh a, M. Mochizuki b, R. Singh(2015)," A review of car waste heat recovery systems utilising thermoelectric generators and heat pipes", Applied Thermal Engineering 101 (2016) 490–495
2. Daniel Champier(2017)," Thermoelectric generators: A review of applications", Energy Conversion and Management 140 167–181.
3. Rong Shen , Xiaolong Gou, Haoyu Xu , Kuanrong Qiu(2017)," Dynamic performance analysis of a cascaded thermoelectric generator", Applied Energy 203 808–815
4. Saniya LeBlanc(2014)," Thermoelectric generators: Linking material properties and systems engineering for waste heat recovery applications", Sustainable Materials and Technologies 1–2 26–35
5. Bradley Orr*, Aliakbar Akbarzadeh(201)," Prospects of waste heat recovery and power generation using thermoelectric generators", Energy Procedia 110 250 – 255
6. A. Kyarad and H. Lengfellnera(2004)," Al–Si multilayers: A synthetic material with large thermoelectric anisotropy", APPLIED PHYSICS LETTERS VOLUME 85, NUMBER 23
7. T Kanno ,S Yotsuhashi,A Sakai,K Takahashi, and H Adachi(2009)," Enhancement in transverse thermoelectric power factor of Bismuth/Copper tilted multilayer", APPLIED PHYSICS LETTERS 94, 061917.
8. C. Reitmaier · F. Walther · H. Lengfellner(2011)," Power generation by the transverse Seebeck effect

in Pb-Bi₂Te₃ multilayers”, Appl Phys A (2011)
105:347-349.

9. <http://aip.scitation.org/doi/abs/10.1063/1.4711020>

10. [10] C. Reitmaier · F. Walther · H. Lengfellner (2010),” Transverse thermoelectric devices”, Appl Phys A (2010) 99: 717-722.

11. <http://www.sciencedirect.com/science/article/pii/S1359431117315661>

12. Douglas Paul(2012),” Thermoelectric Energy Harvesting”, University of Glasgow

13. Hung-Hsien Huang, Meng-Pei Lu, and Chien-Neng Liao(2016),” Transverse thermoelectric effect of asymmetrically doped Bi-Sb-Te compounds”, JOURNAL OF APPLIED PHYSICS 119, 205101.

14. N.R. KRISTIANSEN. G.J. SNYDER (2012),” Waste Heat Recovery from a Marine Waste Incinerator Using a Thermoelectric Generator”, Journal of ELECTRONIC MATERIALS, Vol. 41, No. 6, 201

15. H.J. GOLDSMID(2011),” Application of the Transverse Thermoelectric Effects”, Journal of ELECTRONIC MATERIALS, Vol. 40, No. 5.