

# Design of Equipments that helps in Patient Transferring

Hani Haneefa Pookarath<sup>1</sup>, M. Parameswaran<sup>2</sup>

<sup>1</sup>M.Tech student, Department of Production Engineering, Government Engineering College, Thrissur

<sup>2</sup>Professor, Department of Production Engineering, Government Engineering College, Thrissur

\*\*\*

**Abstract** – For a patient who is unable to move after a major surgery, an equipment to ease their transfer from a hospital bed to a stretcher would be a great help. The equipment should help in transferring by allowing less need for the patient’s movement. Not only have the patients, even the nurses faced physical stresses during the transfer of patients.

This paper will discuss the design of equipment which will reduce the difficulties faced by both the patients and the nurses while transferring a patient from bed to stretcher and vice versa.

**Key Words:** Product design, Patient transferring

## 1. INTRODUCTION

Patient transferring can prove to be difficult to patients with spinal injury or patients who have undergone ortho surgery. Transferring them in the sitting posture can prove to be more difficult for them. Two or more nurses will be required to lift them from bed and place them onto the Stretcher. Hence it also proves to be a tedious job for the nurses. Therefore, there is a need for equipment that helps in transferring of patients within a hospital.

For designing the product firstly a study is conducted on the existing products in the market, a survey is conducted among the nurses to find a strong problem definition and finally a product is designed, developing its 2D and 3D designs.

## 2. STUDIES ON EXISTING PRODUCTS

Some of the main products that exist in the market are the sliding mats and sliding sheets. Both these require a change in patient’s posture which will result to be difficult for them. Also the stretcher and the bed should be of the same height.

Some of the advanced products that exist in the market are Barton wheel chair<sup>[1]</sup> and Hoyer’s lift. Hoyer’s lift only allows the transfer of patient in sitting posture. While the Barton wheel chair allows horizontal transfer of patients, but still needs the sliding sheet/mat and the bed and the wheel chair should be of the same height.

## 3. SURVEY AMONG NURSES

By conducting a survey among the nurses through direct interview technique the following informations were obtained.

There always comes a need for more than 2 nurses to transfer the patient from stretcher to bed and vice versa. The patient should be lifted to the height of stretcher while transferring, which is impossible with other’s help. Carelessness can result be dangerous and hence nurses should exert more physical strength.

The patients who face more problems while transferring are patients with broken thigh bone or spinal injury etc.

## 4. 2D DESIGN

From the study and survey it is concluded that the product to be designed should enable the horizontal transfer of the patients and it should prove to be helpful for both the patients and nurses.

Hence several concepts were generated and among from them one suitable concept was selected, in which, a part of the hospital bed is considered as a pallet and a stretcher framework which helps in lifting and carrying the pallet portion. Under the selected concept a hospital bed and a stretcher frame work should be designed.

The standard parameters for designing the products were obtained from existing dimensions followed by hospital bed and stretcher trolley manufacturers.

The resulting 2D design of the products (Hospital Bed and Stretcher Framework) is given below.

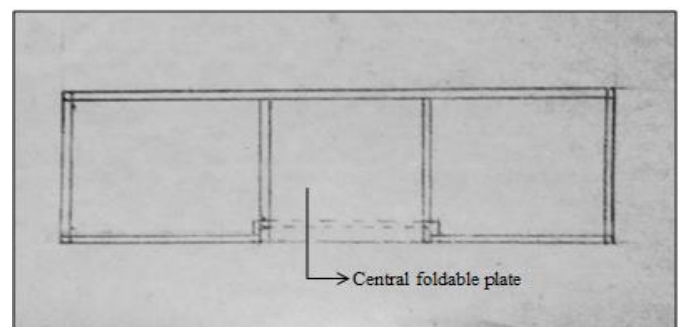

**Fig - 1:** Top view of the Stretcher framework

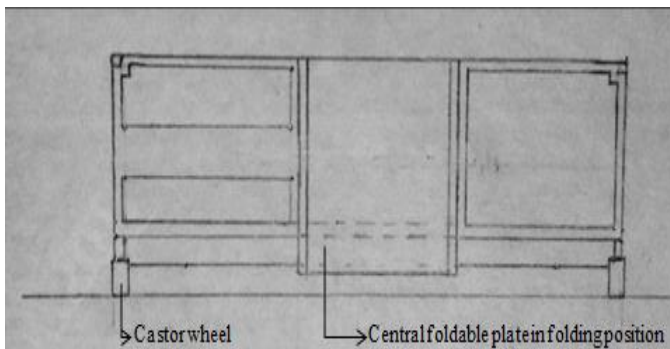

**Fig - 2:** Side (Left) view of the Stretcher framework

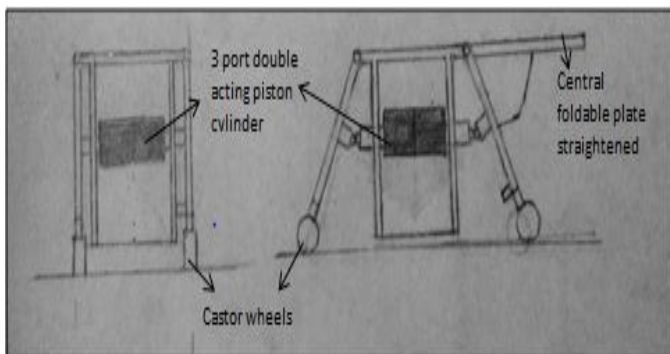

**Fig - 3:** Backside view of the Stretcher framework

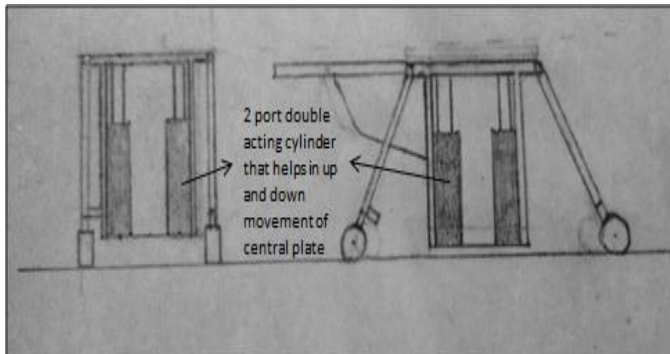

**Fig - 4:** Front view of the Stretcher framework

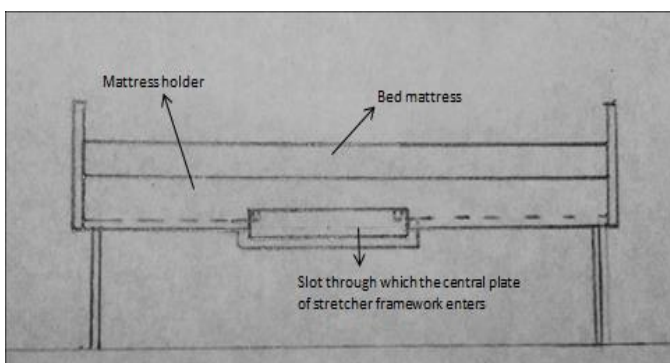

**Fig - 5:** Side (Right) view of the hospital bed

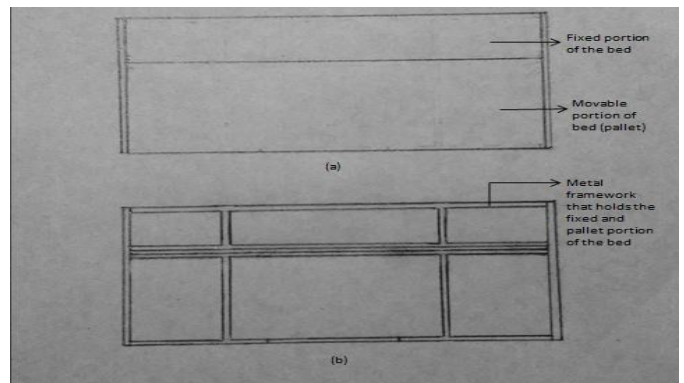

**Fig - 6:** Top view of hospital bed (a) with mattress holder and (b) without mattress holder

### 5. 3D DESIGN

Based on the 2D design developed the 3D design of the products are developed using the 3D designing software Catia. The 3D design of the Hospital bed and Stretcher framework are given below.

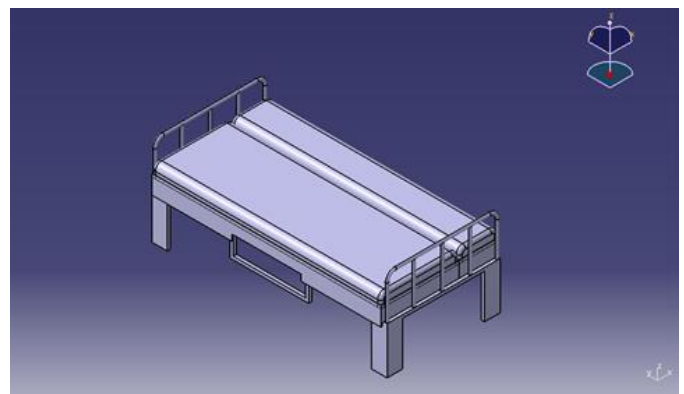

**Fig - 7:** 3D design of the hospital bed

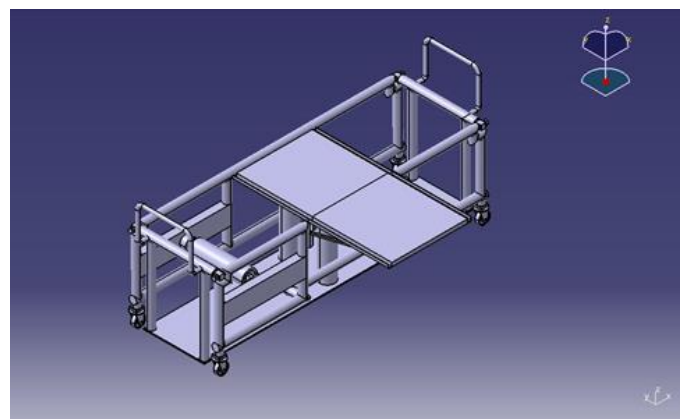

**Fig - 8:** 3D design of the stretcher framework

### 5.1 Proposed Working Procedure

First the legs of the stretcher framework move apart to prevent it from falling while lifting pallet portion of bed, with the help of a 3-port double acting hydraulic piston cylinder. The central foldable plate of the stretcher framework lifts the movable pallet portion of the bed along with the patient on it to a height above the stretcher with the help of two 2-port double acting hydraulic piston cylinders. After lifting the pallet is slid on to the stretcher framework with the help of a rail mechanism on the sides of the foldable central plate of stretcher and finally the legs of the stretcher retracts to old position and the patient is safe and transported.

### 5.2 3D Rendering of the Design

After 3D rendering of the design developed using KeyShot software the final 3D design is as given below.

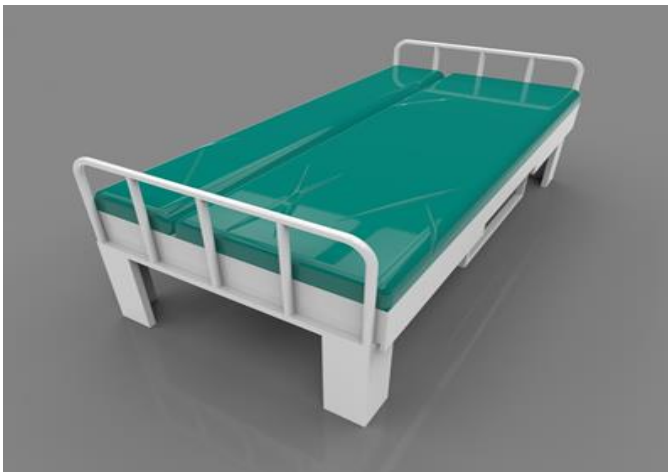

**Fig – 9:** Top view of the hospital bed after 3D rendering

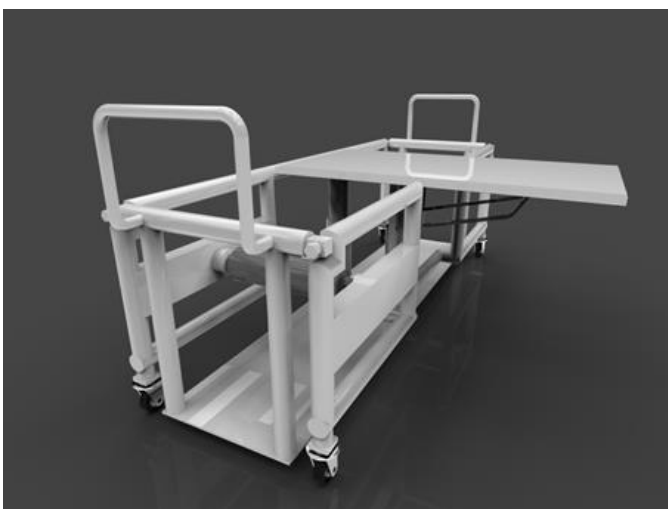

**Fig – 10:** Top view of the hospital bed after 3D rendering

### 6. CONCLUSIONS

The product designed will help in the transfer of patient from bed to stretcher with ease avoiding either the patient or the nurse from facing any difficulty. The final product can be validated using simulation softwares or any other methods like developing a prototype etc.

### REFERENCE

Barton transfer chair, [www.atimedical.net/Catalog/Online-Catalog-Product/1184/Barton-Transfer-Chair](http://www.atimedical.net/Catalog/Online-Catalog-Product/1184/Barton-Transfer-Chair)