

Various Optimization Techniques of Hybrid Renewable Energy Systems for Power Generation: A Review

Kumaresh Rout¹, Jayanta Kumar Sahu²

^{1,2}PhD Scholar, Department of Electrical Engineering, KIIT University, Bhubaneswar, Odisha, India

Abstract – Nowadays, the energy demand is increasing with the population growth but the available limited non-renewable fossil fuel resources unable to meet the demands for a longer period of time. Renewable energy technologies are suitable for off-grid services, serving the remote areas without having to build or extend expensive and complicated grid infrastructure. A combination of two or more renewable energy sources is more effective than a single source in terms of cost, efficiency and reliability. This is called as Hybrid Renewable Energy System (HRES) and is becoming a fast developing market worldwide. This paper is a review of various optimization techniques of hybrid renewable energy systems for power generation.

Keywords: hybrid energy system, reliability, cost, unit optimization, storage, energy management, Hybrid Renewable Energy System (HRES).

1. INTRODUCTION

A hybrid renewable energy system (HRES), or hybrid power, usually consists of two or more renewable energy sources used together to provide increased system efficiency as well as greater balance in energy supply [1]. Rapid depletion of fossil fuels has increases an urgent need for alternative sources of energy to cater the continuously increasing energy demand. Another major reason to reduce our consumption of fossil fuels is the growing global warming phenomena. Environmentally friendly power generation technologies will play an important role in future power supply. The renewable energy technologies include power generation from renewable energy sources, such as wind, PV(photovoltaic), MH(micro hydro), biomass, ocean wave, geothermal and tides. However, renewable energy resources are highly site-specific and intermittent in nature. Therefore, as demand increases in stand-alone mode, single technology based system are associated with high system cost and low reliability, and thus the concept of hybrid renewable energy system has been introduced for power generation in stand-alone applications to deal with such limitations of single technology based system [2, 3].

2. DESCRIPTION OF THE HYBRID SYSTEM

The generation of both wind power and solar power is very dependent on the weather conditions. Thus, no single source of energy is capable of supplying cost-effective and reliable power [4]. With combine of the renewable systems, it is possible that power fluctuations will be incurred. To mitigate or even cancel out the fluctuations, energy storage technologies, such as storage batteries (SBs) can be employed. The proper size of storage system is site specific and depends on the amount of renewable generation and the load [5, 6]. The needed storage capacity can be reduced to a minimum when a proper combination of wind and solar generation is used for a given site.

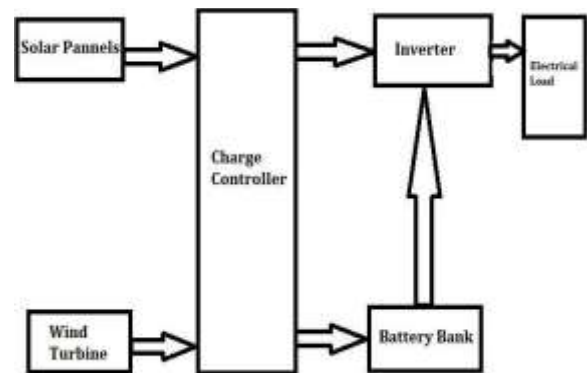

Fig. 1. Block diagram of a hybrid generation unit

2.1 PV System

A photovoltaic (PV) system is a system composed of one or more solar panels combined with an inverter and other electrical and mechanical hardware that use energy from the Sun to generate electricity [7]. PV systems can vary greatly in size from small rooftop or portable systems to massive utility-scale generation plants. Although PV systems can operate by themselves as off-grid PV systems, this article focuses on systems connected to the utility grid, or grid-tied PV systems [8].

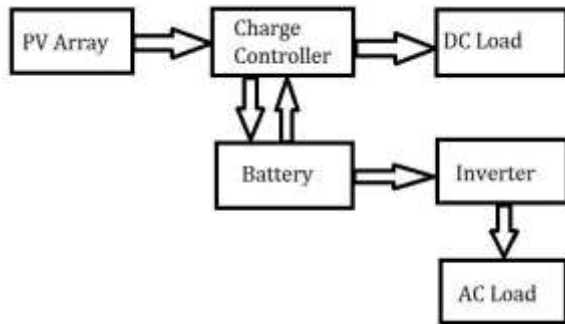

Fig. 2. Diagram of PV System with battery storage powering DC & AC Loads

2.2 Wind Turbine

The wind turbines convert the mechanical energy that is produced by the wind to electrical energy. To use this electrical energy a voltage and a frequency regulation has been needed. Wind turbines operate on a simple principle. The energy in the wind turns two or three propeller-like blades around a rotor. The rotor is connected to the main shaft, which spins a generator to create electricity.

3. ESSENTIALS OF HYBRID SYSTEM OPTIMIZATIONS

In order to select an optimum combination for hybrid system to meet the load demand, evaluation must be carried out on the basis of power reliability and system life-cycle cost.

3.1 Power System reliability

There are various methods used to calculate the reliability of the hybrid system. Loss of power supply probability (LPSP) [10, 11], Loss of Load Probability (LOLP), System Performance Level (SPL) [8], and Loss of Load Hours (LOLH). LPSP is the probability that an insufficient power supply results when the hybrid system is unable to satisfy the load demand. The LOLP is a measure of the probability that the system demand will exceed the system's power supply capacity in a given time period. The SPL is defined as the probability that the load cannot be satisfied [12]. Al-Ashwal and Moghram [13] presented a method for the assessment on the basis of the loss of load risk (LOLR) to decide a proportion for solar and wind energy in a hybrid system.

3.2 System cost

There are several economic criteria for the system cost analysis, such as Net present Cost, Levelised Cost of Energy [9] and life-cycle cost [10]. The life of PV modules is generally considered as the life of the system [11]. The Levelised cost of energy is defined as the ratio of the total annualized cost of the system to the annual electricity delivered by the system.

4. HRES OPTIMIZATION TECHNIQUES

A well designed simulation program permits to determine the optimum size of battery bank, PV array, Wind turbine, Hydro generation capacity and other generation system for an autonomous or grid integrated HRES for a given load. Various optimization techniques such as graphical construction, probabilistic approach, iterative technique, artificial intelligence (AI), dynamic programming, linear programming and multi-objective were used by researchers to optimize hybrid PV/wind energy system.

4.1 Graphical Construction

Graphical Construction method has been presented by Borowy and Salameh [15] based on using long-term data of solar radiation and wind speed recorded for every hour of the day for 30 years. Another type of graphical technique has been given by Markvart [16] to optimally design a hybrid solar- wind power generation system by considering the monthly-average solar and wind energy values.

4.2 Probabilistic Approach

Probabilistic approach of sizing account the effect of the solar radiation and wind speed variability's in the system design. Bucciarelli [17] proposed a sizing method treating storage energy variation as a random walk. The probability density for daily increment or decrement of storage level was approximated by a two-event probability distribution [18].

4.3 Iterative Technique

Iterative Technique is one of the methods of HRES optimization techniques. Yang et al. [19] proposed a Hybrid Solar-wind System Optimization (HSWSO) model, which utilizes the iterative optimization technique following the LPSP model and Levelised Cost of Energy model for power reliability and system cost respectively. Similarly, an iterative optimization method was presented

by Kellogg et al. [20] to select the wind turbine size and PV module number using an iterative procedure to make the difference between the generated and demanded power (DP) as close to zero as possible over a period of time.

4.4 Artificial Intelligence

Artificial Intelligence is an area of computer science that emphasizes the creation of intelligent machines that work and reach like humans. Some of the activities computers with artificial intelligence are designed for include speech recognition, learning, planning, and problem solving. Artificial intelligence methods, such as Artificial Neural Networks, Genetic Algorithm, Fuzzy Logic, PSO (Particle Swarm Optimization, ACO (Ant Colony Optimization) widely used to optimize a hybrid system in order to maximize its economic benefits. Kalogirou [21] proposed an optimization model as solar systems using Artificial Neural Network and Genetic Algorithm. These methods are most successful methods as they help in finding the global solution of complex problems.

4.5 Software based Approach

One of the popular commercial software for designing and analyzing hybrid power system is HOMER of National Renewable Energy Laboratory (NREL)/USA [22]. Solar insolation, electrical load, hybrid generator technical details, costs, constraints, controls and type of dispatch strategy are used as the input to the HOMER software.

5. FUTURE SCOPE

The renewable energy systems have come a long way in terms of research and development. But there are still certain difficulties in terms of their efficiency and optimal use. Following are the challenges faced by the designer. The renewable energy sources, such as solar PV and FCs, need innovative technology to harness more amount of useful power from them. The poor efficiency of solar is major obstruction in utilizing its use. The manufacturing cost of renewable energy sources needs a major reduction. It should be confirmed that there should be minimum amount of power loss in the power electronic devices. The storage technologies need to increase their life-cycle through innovative technologies

6. CONCLUSION

This paper gives an overview of hybrid renewable energy systems (HRES). Various aspects such as methodology, unit sizing and optimization, storage and energy flow

management, are specifically reviewed. Future trends as well as challenges are also presented in the paper. The presented literature review facilitates interested researchers in design and power management of HRES.

REFERENCES

- [1] Lazarov VD, Notton G, Zarkov Z, Bochev I. Hybrid power systems with renewable energy sources types, structures, trends for research and development. In: Proc of International Conference ELMA. 2005.p. 515– 20.
- [2] Prabodh Bajpai, Vaishalee dash, –Hybrid renewable energy systems for power generation in stand-alone applications: A review||, Renewable energy, Volume 16, Issue 5, June 2012, Pages 2926-2939.
- [3] Nehrir, M.H.; Wang, C.; Strunz, K.; Aki, H.; Rama kumar, R, – A Review of Hybrid Renewable/Alternative Energy Systems for Electric Power Generation: Configurations, Control, and Applications||, IEEE Transactions on Sustainable Energy, Volume 2, Issue 4, Oct 2011, Pages 392 – 403.
- [4] Wichert, B. –PV-Diesel hybrid energy systems for remote area power generation – A review of current practice and future developments||. Renewable and Sustainable Energy reviews. Volume 1, No. 3, September 1997, pages 209-228.
- [5] Buckeridge JS, Ding JJ. Design considerations for a sustainable hybrid energy system. IPENZ Transactions 2000; 27(1):1-5.
- [6] Hybrid Wind/PV/Diesel Generation in a Stand-Alone Power System Using Markov Based Genetic Algorithm IEEE TRANSACTIONS ON POWER DELIVERY, VOL. 27, NO. 2, APRIL 2012.
- [7] J. Bhagwan Reddey, D.N. Reddy –Probabilistic Performance Assessment of a Roof Top Wind, Solar Photo Voltaic Hybrid Energy System||, Engineering Science and Education Journal, Vol. 2, No. 4, pp. 281-298, February 2008.
- [8] Munuswamy, S., Nakamura, K., Katta, A., “Comparing the cost of electricity sourced from a fuel cell-based renewable energy system and the national grid to electrify a rural health centre in India: A case study”, Renewable Energy, vol. 36, pp. 2978- 2983, 2011.

- [9] K. Agbossou, M. Kolhe, J. Hamelin, and T. K. Bose, "Performance of a standalone renewable energy system based on energy storage as hydrogen," *IEEE Trans. Energy Convers.*, vol. 19, no. 3, pp. 633–640, Sep. 2004.
- [10] Valente LCG, Almeida SCAD. Economic analysis of a diesel/photovoltaic hybrid system for decentralized power generation in northern Brazil. *Energy* 1998; 23(4):317–23.
- [11] Dufo-López R, Bernal-Agustín JL. Design and control strategies of PV–diesel systems using genetic algorithms. *Solar Energy* 2005; 79(1):33–46.
- [12] Li C-H, Zhu X-J, Cao G-Y, Sui S, Hu M-R. Dynamic modeling and sizing optimization of stand-alone photovoltaic power systems using hybrid energy storage technology. *Renewable Energy* 2009; 32(3):815–26.
- [13] Khan MJ, Iqbal MT. Pre-feasibility study of stand-alone hybrid energy systems for applications in Newfoundland. *Renew Energy* 2005; 30(6):835–54.
- [14] Zoulias EI, Lymberopoulos N. Techno-economic analysis of the integration of hydrogen energy technologies in renewable energy based stand-alone power systems. *Renew Energy* 2007; 32(4):680–96.
- [15] Borowy BS, Salameh ZM. Methodology for optimally sizing the combination of a battery bank and PV array in a wind/PV hybrid system. *IEEE Trans Energy Convers* 1996; 11(2):367–73.
- [16] Markvart T. Sizing of hybrid PV–wind energy systems. *Solar Energy* 1996; 59(4).
- [17] Bucciarelli Jr LL. Estimating loss-of-power probabilities of standalone photovoltaic solar energy systems. *Solar Energy* 1984; 32(2):205–9.
- [18] Bagul AD, Salameh ZM, Borowy B. Sizing of a stand-alone hybrid wind photovoltaic system using a three-event probability density approximation. *Solar Energy* 1996; 56(4).
- [19] Yang HX, Lu L, Zhou W. A novel optimization sizing model for hybrid solar–wind power generation system. *Solar energy* 2007; 81(1):76–84.
- [20] Kellogg WD et al. Generation unit sizing and cost analysis for stand-alone wind, photovoltaic and hybrid wind/PV systems. *IEEE Trans Energy Convers* 1998; 13(1):705.
- [21] Mellit A, Kalogirou SA, Hontoria L, Shaari S. Artificial intelligence techniques for sizing photovoltaic systems: a review. *Renew Sustain Energy Rev* 2009; 13(2):406–19.
- [22] Abbas Babaei et al., "Optimizing and Economical Assessment of the Utilization of Photovoltaic Systems in Residential Buildings: The Case of Sari Station, Northern of Iran", *Australian Journal of Basic and Applied Sciences*, vol. 6, pp 133 -138, 2012.