

Flexural Behaviour of RC Beam with Partial Replacement of Coarse Aggregate by Coconut Shell

Tejaswini T. Shinde¹, M.V.Nagendra²

¹ PG Student, Civil department, Padmabhooshan Vasanttraodada Patil Institute of Technology, Sangli, Maharashtra, India

² Associate Professor, Civil department, Padmabhooshan Vasanttraodada Patil Institute of Technology, Sangli, Maharashtra, India

Abstract - The rapid development in construction industry increasing demand for new innovative material as a part of construction industry. Coconut is grown in more than 93 countries. India is the third largest, having cultivation on an area of about 1.78 million hectares. The properties of coconut shell aggregate concrete are examined and the use of coconut shell aggregate in construction is tested. Experimental studies are conducted on the effect of coconut shell used in proportions of 5%, 10%, 15%, 20% and 25% to replace coarse aggregate in conventional concrete (M20 grade and M30 grade).

As a present scenario research carried out on RC beams by using coconut shell as coarse aggregate yet not found. This study will therefore focus on reinforced concrete beams with partial replacement of coarse aggregate by coconut shell for M20 and M30 grade concrete are carried out. Twelve specimen of beam having a size 700 X 150 X 150 mm were casted. After 28 days they were tested by using UTM of 1000KN under two point loading with shear span of 210mm. Possibility & feasibility of compressive and flexural strength of coconut shell concrete for cube and beam specimens are determined respectively. The obtained results are compared with that of conventional mix. From study, we find out the optimum percentage for replacement of coarse aggregate by coconut shell and we can encourage the use of these 'seemingly' waste products as construction material in Civil engineering.

Key Words: Coarse aggregate, coconut shell, compressive strength, flexural strength, conventional concrete.

1. INTRODUCTION

Concrete is the vital civil engineering material. Its manufacturing involves utilization of ingredients like cement, sand, aggregate, water and required admixtures. The coarse aggregate is the main constituent of concrete mix. Demand of construction material is increased due to infrastructural development across the world. That high demand for concrete in the construction using normal weight aggregate such as gravel and granite drastically reduces the natural stone deposits and this has damaged the environment there by causing ecological imbalance, there is a need to explore and to find out suitable replacement material to substitute the natural stone. Therefore it is necessary to encourage or research on sustainable material

which will help to use such waste material as construction material with less cost and safety of structure. The coconut shell is the agricultural waste product and simultaneously its use in construction material will reduce the environmental problem of solid.

1.1 Properties of Coconut Shell

Coconut shell has high strength and modulus properties. It has added advantage of high lignin content. High lignin content makes the composites more weather resistance. It has low cellulose content due to which it absorbs less moisture as compare to other agriculture waste. Coconuts being naturally available in nature and since its shell are non-biodegradable; they can be used readily used in concrete which may fulfil almost all the qualities of the original form of concrete. [3]

1.2 Coconut Shell Aggregate

Here coconut shells which were collected already broken into two pieces were collected from local temple or restaurants, hotels etc. then they are get air dried for five days approximately at the temperature of 25 to 30°C, removed fibre and husk on dried shells; further broken the shell into small chips manually using hammer and sieved through the set of sieve which is shown in fig 1.1. The material passed through 20 mm sieve and retained on 12.5 mm sieve was used to replace coarse aggregate with CS. The material passing through 12.5mm sieve was discarded. Water absorption of the CS was 20 % and specific gravity at saturated surface dry condition of the material was found as 1.29.

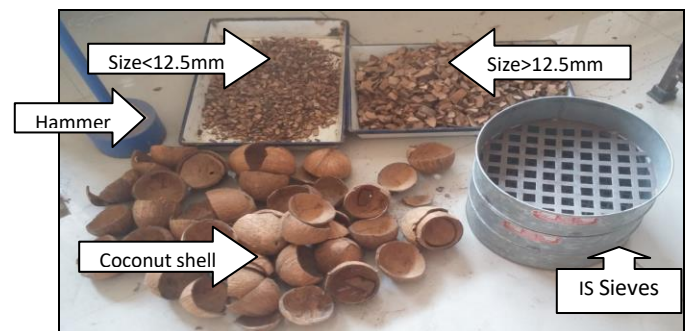

Fig.1.1: Preparation of Coconut Shell Aggregate

2. LITERATURE REVIEW

Teo DCL, Mannan MA, Kurian VJ (2006), have constructed the structure to show the potential use of oil palm shell (OPS) concrete. In actual project, a small footbridge of 2 m in span and a low cost house with a floor area of 59 m², both using OPS concrete were constructed on the campus of University Malaysia Sabah (UMS). These structures are located near the coastal area, which has an annual rainfall of about 2500 mm, air temperature in the range of 23–32°C and relative humidity of 72–91%. [8]

Dewanshu Ahlawat, L.G.Kalurkar (2010), have conducted the experimental study on M 20 grade of concrete with partial replacement granite by coconut shell. Forty five cubes were casted and their compressive strength and workability were evaluated at 7, 14 and 28 days. The compressive strength of concrete reduced as the percentage replacement increased. Concrete produced by 2.5%, 5%, 7.5%, 10% replacement attained 28 days compressive strength of 19.71, 19.53, 19.08, 18.91 respectively. These results showed that Coconut shell concrete can be used in reinforced concrete construction. Its utilization is cost effective and eco-friendly. [5]

Gunasekaram K, Kumar PS, Lakshmi pathy M (2011), have concluded that CS (coconut shell) concrete has better workability because of the smooth surface on one side of the shells. The air-dry densities of CS concrete of the typical mixes are within the range of structural LWC (Light Weight Concrete). The flexural strength of CS concrete is approximately 17.53% of its compressive strength. The splitting tensile strength of CS concrete is approximately 10.11% compressive strength. The impact resistance of CS concrete is high when compared with conventional concrete. [6]

Payam Shafigh, Mohd Zamin Jumaat, Hilmi Bin Mahmud, Norjidah Anjang Abd Hamid (2012), have carried out the experiment by replacing normal weight aggregate by Oil palm shell (OPS) which is a waste lightweight aggregate originating from the palm oil industry, which is approximately 50% lighter than conventional aggregate. In this study, crushed old OPS was used as coarse aggregate. Compressive strength under different curing conditions and the splitting tensile and flexural strengths were compared with those of the normal weight granite concrete. The test results showed that OPS concrete with a compressive strength in the range of 34–53 MPa has a splitting tensile strength range of 2.8–3.5 MPa and flexural strength range of 4.4–7.0 MPa. The sensitivity of compressive strength of OPS concrete in this study is significantly lower than uncrushed OPS concrete reported in the literature. The sensitivity of OPS concrete, under poor curing regime, can be reduced by decreasing the water/cement ratio, increasing the OPS content or reducing the cement content. It was found that there was no substantial difference in 28-day compressive strength for OPS concretes cured initially for 3, 5 and 7 days. The 28-day compressive, splitting tensile and flexural

strengths of OPS concrete was found to be 38%, 28% and 17%, lower than that of granite concrete, respectively. [7]

Amarnath Yerramala, Ramachandrudu C (2012), have carried out the experimental investigation on properties of concrete with coconut shells (CS) as aggregate replacement. Control concrete with normal aggregate and CS concrete with 10 - 20% coarse aggregate replacement with CS were made. Two mixes with CS and fly ash were also made to investigate fly ash effect on CS replaced concretes. Constant water to cement ratio of 0.6 was maintained for all the concretes. Properties like compressive strength, split tensile strength, water absorption and moisture migration were investigated in the laboratory. The results showed that, density of the concretes decreases with increase in CS percent. Workability decreased with increase in CS replacement. Compressive and split tensile strengths of CS concretes were lower than control concrete. Permeable voids, absorption and sorption were higher for CS replaced concretes than control concrete. Coarse aggregate replacement with equivalent weight of fly ash had no influence when compared with properties of corresponding CS replaced concrete. [2]

Tomas U. Ganiron Jr (2013), have studied on generating product using agricultural waste as well develop an alternative construction material that will lessen the social and environmental issues. It also paved the way to the recognition of using coconut shells and fiber as substitute for aggregates in developing concrete hollow blocks. This paper presents the result on the workability and compressive strength of concrete containing various percentage of coconut shell content as partial aggregate replacement. Workability test and compressive strength test were conducted in accordance to ASTM C136 and ASTM C137 respectively. Results show that replacement of appropriate coconut shell content able to produce workable concrete with satisfactory strength. Integration of coconut shell enhanced the strength of concrete making it to be the highest as compared to conventional concrete mixture. [11]

B.Damodhara Reddy, S.Aruna Jyothy, Fawaz Shaik (2014), have conducted the experimental investigation on concrete with different coarse aggregate. The properties of coconut shell and coconut shell aggregate concrete is examined and the use of coconut shell aggregate in construction is tested. The project paper aims at analyzing flexural and compressive strength characteristics of with partial replacement using M30 grade concrete. The project also aims to show that Coconut shell aggregate is a potential construction material and simultaneously reduces the environment problem of solid. Beams are casted, tested and their physical and mechanical properties are determined. The main objective is to encourage the use of these "seemingly" waste products as construction materials in low-cost housing. [4]

T.R.M.Nandhini, P.Balamurugan (2016), have concluded that the project will encourage the use of these harm free

waste products as construction materials in low-cost housing. In conventional constructions, the cost of the materials are high and this has necessitated the use of waste material i.e., coconut shell (cocos nusifera) which is also the light weight material. Hence in this current scenario this experimental study of partial replacement of coarse aggregate finds an effective solution in the reduction of land fill cost and also reduces the environment pollution. In this experimental study the partial replacement of coarse aggregate with 0% to 50% of coconut shell waste collected from the agricultural farms and houses were used along with the admixture. They are mixed at M30 graded concrete and the specimens are casted, cured and tested for its compressive strength & with its result the beams are casted and tested for flexural strength. The parameters will be tested for 28 days curing. [9]

T.Subramani, A.Anbuvel (2016), have carried out the experimental investigation on behavior of reinforced concrete beam with coconut shells (CS) as coarse aggregate. Control concrete with normal aggregate and CS concrete with 0 - 20% coarse aggregate replacement with CS were made. Two mixes with CS and fly ash were also made to investigate fly ash effect on CS replaced concretes. Constant water to cement ratio of 0.6 was maintained for all the concretes. Properties like compressive strength, split tensile strength, water absorption and moisture migration were investigated in the laboratory. The properties of coconut shell and coconut shell aggregate concrete is examined and the use of coconut shell aggregate in construction is tested. The project paper aims at analyzing flexural and compressive strength characteristics of with partial replacement using M25 grade concrete. [10]

Ajay Tharwani, Ashish Sablani, Gaurav Batra, Sakshi Tiwari, Divya Reel, Manish N. Gandhi (2017), have studied the effect of coconut shell on the strength of concrete when used in replacement of aggregate. The tests were conducted on concrete with varying percentage of coconut shell (5%, 10% and 15%). Data presented include strength and slump value of concrete. The use of coconut shells can also help the prevention of the environment and also help economically. Sun drying shell should be used to make sure biodegradable materials decay before its mixing with concrete. It also contributes to sustainable construction. The aim of this paper is to spread awareness about the utilization of coconut shell as a construction material in civil engineering. [1]

3. OBJECTIVES

- To study the flexural behavior of RC beam with partial replacement of coarse aggregate by coconut shell.
- To prepare mix design for M20 grade and M30 grade concrete.

- Experimental investigation of the concrete cube and beam specimen that are cast with different Coconut shell content for replacement of coarse aggregate.
- To study the behavior of compressive and flexural strength of coconut shell concrete.
- To find out the optimum percentage for replacement of coarse aggregate by coconut shell.
- To study the cost comparison for production of conventional concrete and Coconut shell concrete.

4. METHODOLOGY

In order to accomplish the objectives, the project work has been divided into seven major parts. They are:

- The Coconut shell samples are to be collected from nearby sources located in area.
- Mix design will be prepared for M20 grade and M30 grade concrete according to IS: 10262-2009.
- Test samples will be prepare containing different proportions (i.e. 10%,15%,20% and 25%) of Coconut shell and tested to get optimum strength with partial replacement of normal weight aggregate by coconut shell.
- The various tests like Compressive Strength and Flexural Strength are perform on casted cube and beam specimen respectively, as per the specified procedure of IS Codes.
- The obtained results are compared with that of conventional mix.
- Comparison to be made between these analysis, to know possibility and feasibility.
- Conclusions will be drawn from the results of analysis.

5. MATERIALS AND EXPERIMENTAL PROCEDURE

The constituent materials used in this project were obtained from local sources and these were Pozzolana Portland Cement (P.P.C), sand as fine aggregate, crushed granite and coconut shell both as coarse aggregate. Potable water was used for mixing and curing.

5.1 Concrete

The concrete used for casting was prepared in the testing laboratory using a hand mix method of concrete. The concrete was (M20 and M30 Grade) with mix proportion adopted was (1: 1.432: 3.112) and (1: 1.228: 2.671) with water to cement ratio of 0.50 and 0.44 respectively. The material proportions per cubic meter of concrete:

A) For M20 grade concrete:

- 1) 1193.368 kg/m³ of coarse aggregate (maximum size 20mm)
- 2) 548.775 kg/m³ of natural river sand (sp.gr =2.608)
- 3) 383.16 kg/m³ of Pozzolana Portland Cement (P.P.C.)
- 4) 191.58 liters of water

B) For M30 grade concrete:

- 1) 1162.998 kg/m³ of coarse aggregate (maximum size 20mm)
- 2) 543.809 kg/m³ of natural river sand (sp.gr =2.608)
- 3) 435.409 kg/m³ of Pozzolana Portland Cement (P.P.C.)
- 4) 191.58 liters of water

5.2 Compressive Strength Test

A) Preparation of Specimens:

M-20 & M-30 grade of concrete was designed by I.S 10262-1982. Batching was done as per the mix proportions with the help of electronic weigh balance. Placing and Compaction was done. The moulds were greased from inside for easy demoulding. Place the fresh concrete in cubes in 3 layers, tamping each layer 25 times. The entrapped air in concrete is removed by table vibrator shown in fig.5.1. Concrete cubes are now kept in curing tank for 3, 7 and 28 days. After 28 days, concrete cubes were removed from curing tank to conduct tests on hardened concrete by using CTM as shown in fig.5.1.



Surface Vibrator

Compression Testing Machine (CTM)

Fig. 5.1: Equipments used for compression testing of cube specimen

B) Results and Discussion:

Compressive Strength: Cubes were placed in Compression Testing Machine (C.T.M), and load was applied. The readings on display of machine were recorded and compressive

strength was calculated. The results of Compressive strength are shown in Table 5.1 and 5.2.

Table 5.1: Compressive Strength of Coconut Shell Concrete (N/mm²)

M20 grade concrete

Curing Days	0% CS	5% CS	10% CS	15% CS	20% CS	25% CS
3	14.30	12.25	11.85	11.50	9.85	9.25
7	18.867	16.73	13.60	115.73	13.20	12.33
28	27.80	22.70	20.50	22.83	20.30	19.23

Table 5.2: Compressive Strength of Coconut Shell Concrete (N/mm²)

M30 grade concrete

Curing Days	0% CS	5% CS	10% CS	15% CS	20% CS	25% CS
3	14.90	11.80	11.20	11.65	9.60	9.35
7	18.86	17.46	15.43	16.13	13.76	13.20
28	29.83	24.46	23.06	24.73	20.16	19.40

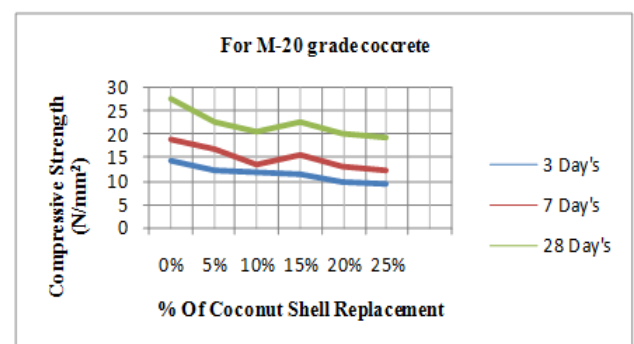

Fig.5.2: Graph Shows Variation in compressive strength (28 days) with age for M20 grade concrete

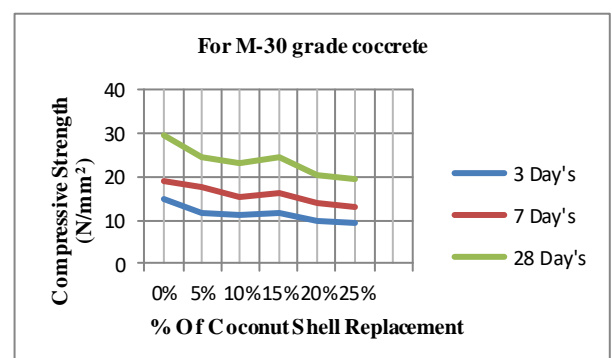

Fig.5.3: Graph Shows Variation in compressive strength (28 days) with age for M30 grade concrete

From above fig.5.2 and 5.3 it is clear that the compressive strength holds well up to 15% replacement of coarse aggregate by coconut shell. The percentage increased above 15% the compressive strength decreases significantly.

5.3 Flexural Strength Test

A) Details of the R.C. Beam:

While reviewing literature of beam come to know that the beam size is 700X150X150 mm. As accorded to the IS (10086-1982) & IS (516-1959) minimum size of specimen for beam mould is 700X150X150mm.

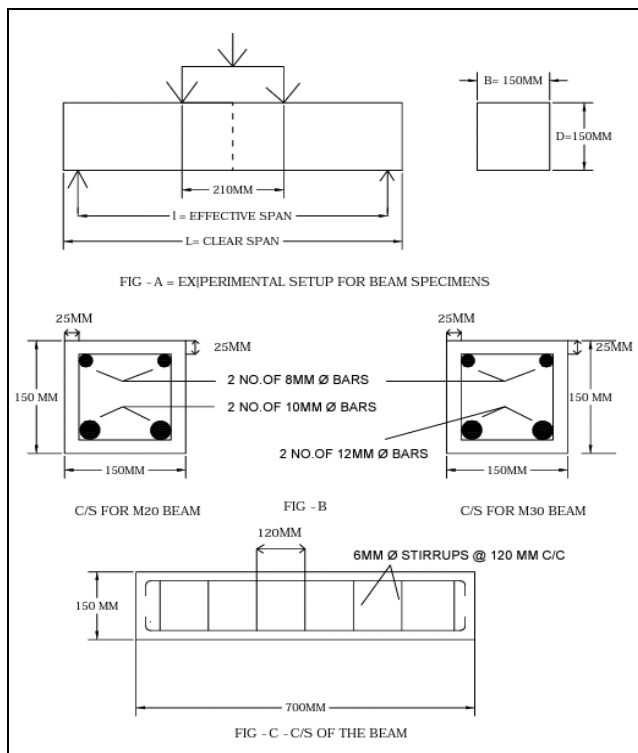

Fig.5.4: Details of R.C. Beam

B) Casting and curing of specimens:

The wooden beam mould was used for casting the beam specimens. Before mixing the concrete, the moulds were kept ready by placing it on horizontal surface. The sides and bottom of all the moulds were properly greased for easy demoulding. The concrete was placed in the mould and proper care was taken for uniform compaction using tamping rod and surface finish throughout the beam. After 24 hours the specimen is demoulded and is cured for 28 days. Then the beam is dried in air for 12 hours after curing before the testing.



Fig.5.5: Preparation of Mix and Casting of beam specimens

C) Testing of specimens:

The beams were cured for 28 days to achieve the approximate flexural strength and they are tested using the Universal Testing Machine (UTM) of 1000KN capacity. The beams are tested as simply supported beam with two point loads until failure. The load positions were spaced at 210 mm c/c which is one-third of the span. Fig.5.6 shows Flexural Strength Test on Beam using Universal Testing Machine (UTM).



Fig. 5.6: Flexural Strength Test on Beam using Universal Testing Machine (UTM)

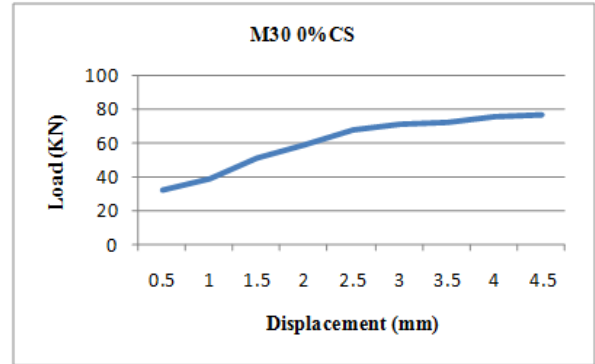

Fig. 5.7: Data acquisition on UTM for beam

The flexural strength was recorded in table 5.3. The flexural strength is very much dependent on the physical compressive strength of coarse aggregate. Flexural strength is equal to $0.7\sqrt{f_{ck}}$ where f_{ck} is characteristics compressive strength of conventional concrete. Therefore similar to compressive strength, flexural strength also decreases with increase in CS replacement.

Table 5.3: Flexural strength of M20 and M30 grade R.C. beam

Grade of concrete	28 days flexural strength (N/mm ²)	
	0% CS	15% CS
M20	3.212	2.477
M30	3.397	2.678



Graph 6.2: Load Vs Displacement curve for beam B6 M20 grade concrete with 15% CS replacement

6. RESULTS

All the 12 number of beams were tested at UTM machine with capacity of 1000KN and following data were obtained.

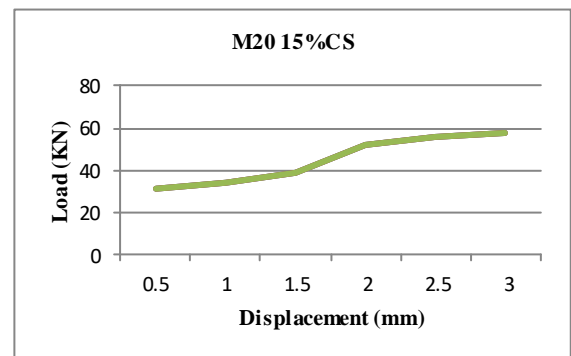

Graph 6.3: Load Vs Displacement curve for beam B9 M30 grade concrete with 0% CS replacement

Grade of concrete	Designation of sample	Load Carried (KN)	Deflection (mm)	Avg. load (KN)
M20 0% CS	B1	71.7	3.38	72.283
	B2	70.85	3.01	
	B3	74.30	3.52	
M20 15% CS	B4	53.07	2.72	55.74
	B5	56.40	2.94	
	B6	57.75	2.96	
M30 0% CS	B7	77.60	4.54	76.45
	B8	72.90	4.32	
	B9	78.85	4.63	
M30 15% CS	B10	59.30	3.24	60.256
	B11	58.55	3.02	
	B12	62.92	3.38	

6.1 General Result

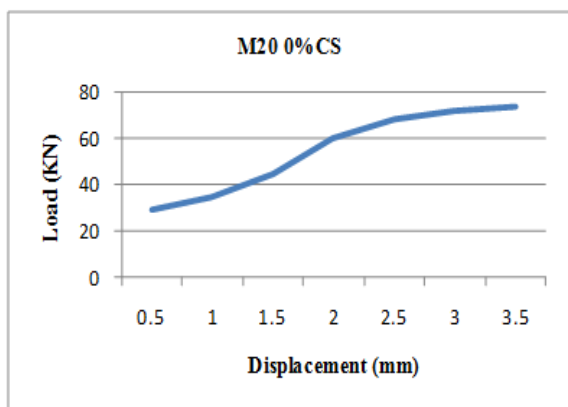

Graph 6.1: Load Vs Displacement curve for beam B3 M20 grade concrete with 0% CS replacement

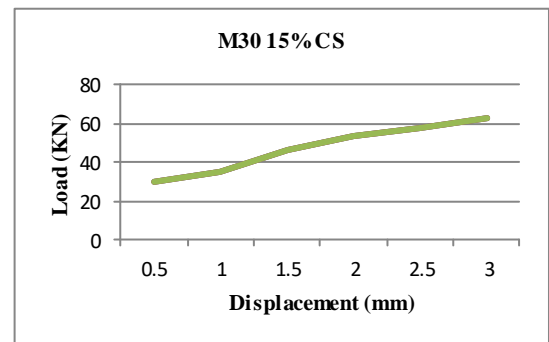

Graph 6.4: Load Vs Displacement curve for beam B12 M30 grade concrete with 15% CS replacement

6. CONCLUSIONS

From the data received after all the secession of test carried out on beam specimens with different replacement level of coconut shell, the following conclusions are drawn.

- Increase in percentage Replacement of coconut shell (CS) reduces compressive and Flexural Strength of concrete.
- Coconut shell can be grouped under lightweight aggregate as the 28 days air-dry densities of coconut shell aggregate concrete are less than 2000

kg/m³. Increase in percentage of coconut shell, decreases densities of concrete.

- Coconut shell concrete (CSC) has better workability because of the smooth surface on one side of the shells and the smaller size of coconut shell. So we could possibly use CSC in concretes where high workability is desirable.
- Lightweight concrete can be prepared by using coconut shell as coarse aggregate.
- It was concluded that the CSs were more suitable as low strength giving lightweight aggregate when used to replace common aggregate in concrete production especially for M20 and M30 grade concrete.
- The optimum replacement of coarse aggregate by coconut shell is obtained as 15%. So that up to 15% environmental pollution gets reduced.
- Solves problem of disposal of CS that's why it leads to sustainable development.

7. FUTURE SCOPE OF PRESENT STUDY

Based on the scope and the results of this research the following are the recommendation for further investigation.

- i. A study of the shrinkage characteristics of Coconut shell Concrete is recommended.
- ii. A long term durability study of Coconut shell concrete should be investigated.
- iii. The study of the development of the micro structure of the coconut shell concrete is important in predicting the long term behavior.
- iv. The use of coconut shell aggregate as a replacement in convectional concrete should be encourage in the locality where it is in abundance to enhance environmental cleanliness.

REFERENCES

- [1] Ajay Tharwani, Ashish Sablani, Gaurav Batra, Sakshi Tiwari, Divya Reel, Manish N. Gandhi, "Study of Strength of Concrete by Using Coconut Shell", IJISSET - International Journal of Innovative Science, Engineering & Technology, Vol. 4 Issue 5, May 2017.
- [2] Amarnath Yerramala, Ramachandrudu C, "Properties of Concrete with Coconut Shells as Aggregate Replacement", International Journal of Engineering Inventions ISSN: 2278-7461, Volume 1, Issue 6 (October 2012) PP: 21-31.
- [3] Apeksha Kanojia, S.K.Jain, "Performance Of Coconut Shell As Coarse Aggregate In Concrete", A Review (IRJET), Vol.02, Issue:04 July-2015.
- [4] B.Damodhara Reddy, S.Aruna Jyothy, Fawaz Shaik, "Experimental Analysis of the Use of Coconut Shell as Coarse Aggregate", IORS Journal Mechanical and Civil Engineering (IOSR-JMCE) Volume 10, Issue 6 (Jan. 2014) PP 06-13.
- [5] Dewanshu Ahlawat, L.G.Kalurkar, "Coconut Shell as Partial Replacement of Coarse Aggregate in Concrete", IOSR Journal of Mechanical and Civil Engineering (IOSR-JMCE) Dec.(2010) PP 61-64.
- [6] Gunasekaran K, Kumar PS, Lakshmi pathy M, "Mechanical and bond properties of coconut shell concret", Const Build Mater 2011;25(1):92-8.
- [7] Payam Shafigh, Mohd Zamin Jumaat, Hilmi Bin Mahmud, Norjidah Anjang Abd Hamid, "Lightweight concrete made from crushed oil palm shell: Tensile strength and effect of initial curing on compressive strength", Construction and Building Materials 27 (2012) 252-258.
- [8] Teo DCL, Mannan MA, Kurian VJ, "Structural concrete using oil palm shell (OPS) as lightweight aggregate", Turk J Eng Environ Sci 2006;30:251-7.
- [9] T. R. M .Nandhini, P. Balamurugan, "Experimental behavior of R.C. Beam by the partial replacement of coarse aggregate using cocos nusifera (Coconut Shell)", International Research Journal of Engineering and Technology (IRJET) Volume: 03 Issue: 04, Apr-2016.
- [10] T.Subramani, A.Anbuvel, "Experimental Behavior Of Reinforced Concrete Beams With Coconut Shell As Coarse Aggregate", International Journal of Application or Innovation in Engineering & Management (IJAEM) Volume 5, Issue 5, May 2016 ISSN 2319 - 4847.
- [11] Tomas U. Ganiron Jr, "Sustainable Management of Waste Coconut Shells as Aggregates in Concrete Mixture", Journal of Engineering Science and Technology Review 6 (5) (2013) 7-14.