

AUTOMATIC WATER SPRINKLING SYSTEM

Prof. S.M.Wange¹, Sanket Garudkar², Akshay Pendurkar³, Prashant Roopdas⁴, Pranav Bhandari⁵

^{1,2,3,4,5}Department of Mechanical Engineering, Sinhgad Academy of Engineering, Pune, Maharashtra, India

Abstract - Automatic travelling water sprinkler is powered by solar energy. The solar energy is absorbed by the solar panel and the energy is stored as electricity in the battery. This battery gives power to the DC motor. The DC motor is connected with the chain sprocket assembly. The chain and sprocket is connected with the rear shaft which helps the machine to propel forward. At the rear shaft another set of chain and sprocket is also there. The fourth sprocket of second chain is connected with the crank plate via shaft. The crank plate is connected to the piston rod of the cylinder, where the rotary motion of crank plate is converted to the reciprocatory motion in the pneumatic cylinder. The double acting cylinder is connected with the water tank by a non-return valve. The air goes to the water tank pushes water out of the tank. This pushed out water is sprayed through the sprinkler to the plants.

Key Words: water sprinkler, chain and sprocket, crank plate, water tank, sprinkler system.

1. INTRODUCTION

India is a country where nearly 70% of people lives in rural area and main source of their income is farming, directly or indirectly. 70% of people in India are connected with farming directly or indirectly, instead of that we are not producing the crop of which we having capacity to produce. Reason behind this is we farmers of our country are not using technology very well. So we have to make machines that can help then to save their time and money and to increase the production rate and their profit. We have to make economic machineries so farmers can purchase it as per capita income of our country's farmers are low and our country per capita income is low that of compared to other country as our country is developing country. Present scenario in agricultural field in India related to sprayer is that farmers are using hand operated sprayer or motorized sprayer. According to idea in our project we are making a small 4 wheel kart or vehicle which is electronically operated which runs on power source as a DC battery.

India is a vast country where water is very scarce in availability in some regions. Conservation of water is very much important in agriculture due to the various climatic phenomena's. The various alternative modes of irrigation techniques should be adopted to tackle this problem. The developed countries are using several method to conserve and reuse the water. If we check the fact of water availability, two- third of earth is filled by water but only less than one

percent of water can be used for the normal use. This is the point where the conservation of water's importance is arriving. The alternative mode of irrigation technique involves mist and drip type of irrigation. These type of irrigation reduces water wastage to a greater extent. In our project we are adopting the sprinkler mechanism for irrigation. The sprinkler is powered by the double acting pneumatic cylinder, in which on the forward and backward stroke of the cylinder pushes air to the water tank. This air from the cylinder moves the water out of the tank, through the sprinkler. This way ensures proper watering of the crop.

The sun provides sustainable amount of the energy used for various purposes on earth for atmospheric system. Every minute the sun radiates about 5.68×10^{26} calories of energy and the earth intercepts only 2.55×10^{18} calories (NRF, 2010). This represents only 2000 millionth of the total solar energy sent into the space. The total solar energy is estimated to be 30,000 times greater than the total annual energy of the world (Mgbemu, 2005). If we able to convert a very few percent of this much solar energy into the benefit of common man, it will directly ensure the sustainability of our future generation. Solar energy is a time dependent and intermittent energy source. There is need for the storage of energy for later use when there is no further supply of the sun energy. An optimally designed solar electric system will collect and convert when the isolation is available during the day.

Photovoltaic is the direct conversion of light into electricity at atomic level. When free electrons are captured, an electric current is produced and can be used as electricity. The series and parallel electrical arrangements to produce any required voltage. Photovoltaic modules and arrays produce direct-current (DC) electricity and current combination. The chain drive used in the mechanism able to power the vehicle as well as the sprinkler to sprinkle the water to plants. This combined mechanism can deliver effectively better result in irrigation and give mobility to the mechanism to reach places where a permanent sprinkler system is too costly.

2. PROBLEM STATEMENT

Water is scarcely available in some months of the year, water conservation is very much essential for the sustainability. The permanent installation of sprinkler and piping is too costly and it will result in few lakh rupees. The permanent sprinkler system needs lot of primary investment so there is a need of practical solution in between the higher cost and conservation of the water.

3. OBJECTIVE

To design the system to sprinkle the water as well as fertilizer powered by the solar energy.

To fabricate the automatic travelling sprinkler system.

4. LITERATURE SURVEY

[1] Dhawan et al. (2016), has presented the design and development of the solar powered gardener which is based on object detection based on IR sensor. The above implementation was an effort to understand how microcontroller and IR sensor in interface with solar panel as power source and motors to drive the assembly along with a motor to cut grass and a pump to sprinkle water can be used to function as a lawn care taker. Solar power helps the machine to cut the grass and sprinkle the water to plants. The machine was designed such that it can avoid the obstacles automatically, while carrying out its operations of grass cutting and/or water sprinkling.

[2] R. Sathish Kumar et al (2014) presents the automatic irrigation system it optimizes the usage of water by reducing wastage and reduces the human intervention for farmers. The excess energy produced using solar panels can also be given to the grid with small modifications in the system circuit, which can be a source of the revenue of the farmer and same time giving a solution for energy crisis. Proposed system is easy to implement and environment friendly solution for irrigating fields. The system was found to be successful when implemented for bore holes as they pump over the whole day. Solar pumps also offer clean solutions with no danger of borehole contamination. The system requires minimal maintenance and attention as they are self-starting. To further enhance the daily pumping rates tracking arrays can be implemented. This system demonstrates the feasibility and application of using solar PV to provide energy for the pumping requirements for sprinkler irrigation. Even though there is a high capital investment required for this system to be implemented, the overall benefits are high and in long run this system is economical.

[3] Blackmore et al. (2005) presents the need of autonomous system in the farming. The advent of autonomous system architectures gives the opportunity to develop a complete new range of agricultural equipment based on small smart machines that can do the right thing, in the right place, at the right time in the right way. The autonomous farming described in this project includes seed bed preparation, seed mapping, seed placement and reseeding. The crop care includes crop scouting, weed mapping, robotic weeding, micro spraying, robotic gantry and robotic irrigation. Although existing manned operations can be efficient over large areas there is a potential for reducing the scale of treatments with autonomous machines that may result in even higher efficiencies. The development

process may be incremental but the overall concept requires a paradigm shift in the way we think about mechanization for crop production that is based more on plant needs and novel ways of meeting them rather than modifying existing techniques.

5 COMPONENTS USED

5.1 Solar Panel

Photovoltaic principles the photo-voltaic effect can be observed in nature in a variety of materials that have shown that the best performance in sunlight is the semiconductors as stated above. When photons from the sun are absorbed in a semiconductor, that create free electrons with higher energies than the created there must be an electric field to induce these higher energy electrons to flow out of the semiconductor to do useful work. A junction of materials, which have different electrical properties, provides the electric field in most solar cells for the photon interaction in a semiconductor.

5.2 Brushless D.C Motor

This is a relatively new class of motors whose application have been increasing at a rapid rate each year, due to both declining costs as well as increasing functionality. A brushless DC motor is similar to that brush DC motor in that it has an internal shaft position feedback which tells which windings to switch on at which an exact moment. This internal feedback gives both the brush DC motor and brushless DC motor their unique characteristics. Linear speed-torque curves which are well suited for speed and position control and high starting torque.

5.3 Pneumatic Cylinder

Pneumatic cylinder(s) (sometimes known as air cylinders) are mechanical devices which use the power of compressed gas to produce a force in a reciprocating linear motion.

5.4 Chain Drive

Most often, the power is conveyed by a roller chain, known as the drive chain or transmission chain, passing over a sprocket gear, with the teeth of the gear meshing with the holes in the links of the chain. The gear is turned, and this pulls the chain putting mechanical force into the system.

5.5 Sprocket

A sprocket or sprocket-wheel is a profiled wheel with teeth, cogs, or even sprockets that mesh with a chain, track or other perforated or indented material. The name 'sprocket' applies generally to any wheel upon which radial projections engage a chain passing over it. It is distinguished from a gear in that sprockets are never meshed together directly, and

differs from a pulley in that sprockets have teeth and pulleys are smooth.

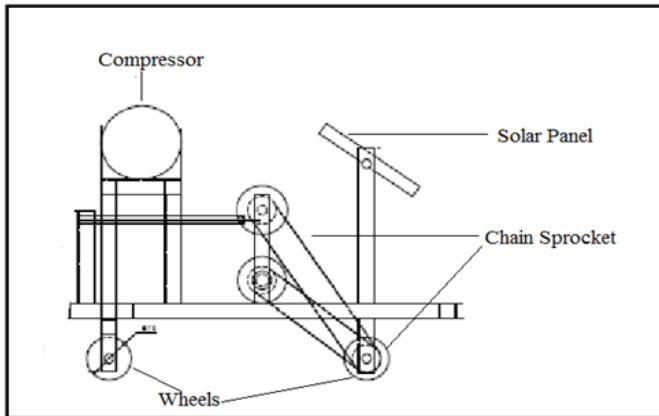

Fig -1: Block diagram of Water Sprinkling Robot

6. WORKING PRINCIPLE

Water Sprinkling Robot powered by solar energy. Solar energy is absorbed by the solar panel and the energy is stored as electricity in the battery. This battery gives power to the DC motor. The DC motor is connected with the chain sprocket assembly. The chain and sprocket is connected with the rear shaft which helps the machine to propel forward. At the rear shaft another set of chain and sprocket is also there. The fourth sprocket of second chain is connected with the crank plate via shaft. The crank plate is connected to the piston rod of the cylinder, where the rotary motion of crank plate is converted to the reciprocatory motion in the pneumatic cylinder. The double acting cylinder is connected with the water tank by a non-return valve. The air goes to the water tank pushes water out of the tank. This pushed out water is sprayed through the sprinkler to the plants.

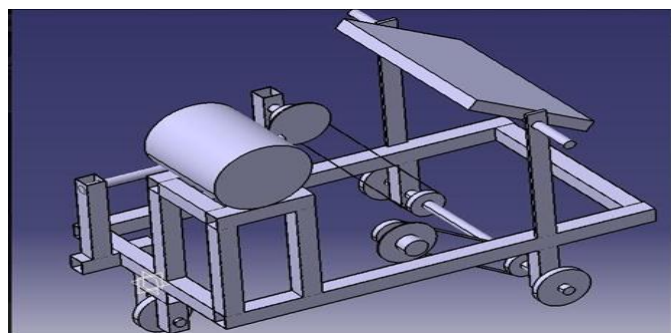

Fig -2: 3D Cad Model of Automatic Sprinkler system

7. CALCULATIONS

7.1 Calculation of double acting pneumatic cylinder

Cylinder Bore: 20mm

Stroke: 50mm

Volume of cylinder = Stroke × Area of Piston.

$$= 50 \times (\pi/4 \times 20^2)$$

$$= 15707.96 \text{ mm}^3$$

Volume of cylinder = Stroke × Area of Piston.

$$= 50 \times (\pi/4 \times (20^2 - 7^2))$$

$$= 13783.73 \text{ mm}^3$$

Total volume = 15707.96 + 13783.73

$$= 29491.69 \text{ mm}^3$$

Outward force of cylinder = pressure × area

$$= 0.4 \times \pi/4 \times D^2$$

$$= 0.4 \times \pi/4 \times 20^2$$

$$= 125.66 \text{ N}$$

Inward force of cylinder = pressure × area (effective)

$$= 0.4 \times \pi/4 \times (D^2 - d^2)$$

$$= 0.4 \times \pi/4 \times (20^2 - 7^2)$$

$$= 110.269 \text{ N}$$

7.2 Chain design

Chain -06 B

Pitch -9.525mm

Roller diameter, d1=6.35 mm

Width, b1=5.72 mm

Transverse pitch pt=54.85 mm

z1=18

z2=18

Approximate centre distance,

a=40p

$$= 64 \times 9.525$$

$$= 609.6 \text{ mm}$$

Our problem centre distance is only 200mm so it is below the feasible limit so our chain is safe

No of links,

$$L_n = 2(a/p) + (z1+z2)/2 + ((z1-z2)/2\pi) \times (p/a)$$

$$= 2(200/9.525) + (18+18)/2 + 0$$

$$= 60$$

Length of chain, L= 571mm

7.3 Design of sprocket

For Used chain no.06 B

For Z=18

All Data from Table 14.6 of Textbook of "Design of machine elements" by V. B. Bhandari

For Z=18

From table no 14.1

Pitch, P=9.525mm

Width between inner plates, b1=5.72

Roller diameter, d1=6.35 mm

Transverse pitch pt=10.24

Pitch circle diameter

$$D = p / (\sin(180/z))$$

$$= 9.525 / (\sin(180/18))$$

$$= 54.85 \text{ mm}$$

Top diameter (Da)

$$(Da)_{\text{max}} = D + 1.25p - d1$$

$$=54.85+1.25*9.525-6.35$$

$$=60.4 \text{ mm}$$

Root diameter

$$D_f = D - 2r_1$$

Butt roller seating radius (r1)

$$(r_1)_{\max} = 0.505d_1 + 0.069\sqrt[3]{d_1}$$

$$= 0.505*6.35 + 0.069\sqrt[3]{6.35}$$

$$= 3.33 \text{ mm}$$

$$D_f = D - 2r_1$$

$$= 54.85 - 2*3.33$$

$$= 48.19 \text{ mm}$$

Tooth flank radius

$$(r_e)_{\max} = 0.008d_1(Z_2 + 180)$$

$$= 0.008*6.35(182 + 180)$$

$$= 25.6 \text{ mm}$$

$$(r_e)_{\min} = 0.12d_1(Z + 2)$$

$$= 0.12*6.35(18 + 2)$$

$$= 15.24$$

Roller seating angle

$$(\alpha)_{\max} = (120 - 90/Z)$$

$$= (120 - 90/18)$$

$$= 115$$

$$(\alpha)_{\min} = (140 - 90/Z) = 140 - 90/18$$

$$= 135$$

Tooth height above the pitch polygon

$$(h_a)_{\max} = 0.625p - 0.5d_1 + 0.8p/Z$$

$$= 0.625*9.525 - 0.5*6.35 + 0.8*9.525/18$$

$$= 3.2 \text{ mm}$$

$$(h_a)_{\min} = 0.5(p - d_1)$$

$$= 0.5(9.525 - 6.35)$$

$$= 1.58 \text{ mm}$$

Tooth side radius (rx)=p

$$\text{Tooth width } bf_1 = 0.95b_1$$

$$= 0.95*5.72$$

$$= 5.434 \text{ mm}$$

$$\text{Tooth side relief } (ba) = 0.1p$$

$$= 0.1*9.525$$

$$= 0.9525 \text{ mm}$$

7.4 Calculation of flow rate of sprinkler

Quantity of water tank, 5 Litre = $5 \times [10]^{-3} \text{ m}^3$

Volume of the air from forward and reverse stroke = $29491.69 [mm]^3$

$$\text{Mass flow rate, } m' = 1.25 \times 29491.69$$

$$= 36864.6125 \times [10]^{-9} \text{ Kg}$$

$$= 36864.6125 \times [10]^{-9} \times 94.2/60 \times 1/2$$

$$= 28938.72 \times [10]^{-9} \text{ Kg/s}$$

8. FUTURE SCOPE

The robot can be interfaced with sensor to send back the information to the user.

The robot can be programmed remotely through a mobile to carry out specific task.

The robotic arm can be modified to have gripper and more versatile arm to carry out more critical jobs.

The robotic arm can be designed with a web cam to send the snap shots of the location.

9. CONCLUSIONS

By implementing the proposed system there are various benefits for the government and the farmers. For the government a solution for energy crisis is proposed. By using the automatic irrigation system it optimizes the usage of water by reducing wastage and reduces the human intervention for farmers.

The excess energy produced using solar panels can also be given to the grid with small modifications in the system circuit, which can be a source of the revenue of the farmer, thus encouraging farming in India and same time giving a solution for energy crisis.

REFERENCES

- [1] Joao Rolim, Jose Teixeira, "The design and evaluation of travelling gun irrigation systems: Enrolador software", Journal of the Brazilian Association of Agricultural Engineering, 2016 ISSN: 1809-4430, v.36, n.5, 917-927
- [2] S. Harishankar, R. Sathish Kumar, Sudharsan K.P, U. Vignesh and T.Viveknath, "Solar Powered Smart Irrigation System", Advance in Electronic and Electric Engineering, 2014, ISSN 2231-1297, Volume 4, Number 4, pp. 341-346
- [3] Varun Dhawan, Anindu Bose, Vishal Danve, "Solar Powered Gardener", International Journal on Recent and Innovation Trends in Computing and Communication, 2016, ISSN: 2321-8169 Volume: 4 Issue: 3 454 - 457
- [4] Simon Blackmore, Bill Stout, Maohua Wang, Boris Runov, "Robotic agriculture - the future of agricultural mechanization" 5th European Conference on Precision Agriculture Uppsala, Sweden 9-12th June 2005