

Feasibility Study for Establishing a Manufacturing Industry for Activated Carbon and Bio Oil Extraction Using Coconut Shell in Vidarbha Region

Rahul Sohani¹, Dr. Achal Shahare²

¹M.Tech Student, Department of Mechanical Engg, G.H.Raisoni Academy of Engineering and Technology, Nagpur

²Professor and Head Department of Mechanical Engg, G.H.Raisoni Academy of Engineering and Technology, Nagpur

Abstract – As we are talking particularly about Vidarbha region so according to present scenario there are very less or almost no manufacturing industries of activated carbon and bio oil extraction from coconut shells in Vidarbha region and demand is more. Also as we are extracting it from coconut shells and coconut shell is considered as waste so we try to make best from waste.

A production plant was designed to produce 6 tons of activated carbon per day from coconut shells, in order to capture 2% of the projected market for activated carbon in water purification applications by 2017-2018. The production process consists of a pyrolysis stage and an activation stage. A downdraft gasifier was utilized as the pyrolysis reactor in order to maximize the energy efficiency of the process, and a separate cyclone and condenser were added to capture and purify the valuable byproducts of the pyrolysis reaction. A fluidized bed reactor was utilized as the activation reactor, due to its superior heat and mass transfer properties over conventional reactors currently used in industry. An extensive heat exchanger network is implemented to capture and recycle the heat and water produced by the activation reaction, in order to minimize the plant's thermal and water footprint. With a profit of 8% per month, the plant is expected to have recovered the whole investment at the end of 4 to 5 years. Due to the expected high product demand and anticipated profits, construction of the plant is strongly recommended.

Keywords- Coconut Shell, Activated Carbon, Bio Oil

1. INTRODUCTION

Coconut is a popular plantation and is grown in more than 90 countries worldwide. The world production of coconut sums up to around 55 million tons annually. Coconut production plays an important role in India. India accounts for 22.34 per cent of the world's coconut production and is one of the major players in the world's coconut trade. According to figures published in December 2017 by the Food and Agriculture Organization of the United Nations, India is the world's third largest producer of coconuts, producing 10,894,000 tons in 2017. Coconut in India is produced in 1894570 ha, and 15729.75 million nuts produced in 2016-2017. The coconut oil; apart from used as

edible oil; has varied industrial applications. It is used in the manufacture of toilet soaps, laundry soaps, surface-active agents and detergents, hair tonics, cosmetics, etc

Here we are extracting Activated Carbon and bio oil using coconut shell. And also then establish a manufacturing industry in Vidarbha region. So we must take into consideration that

- How many Industries are currently working on that topic in Vidarbha region?
- What is the minimum amount of Activated carbon and bio oil should be manufactured so that industry will be in profit?
- How it should be sold and how the price should be calculated?
- How advertisement of product should be done? So that more and more people will be aware about it.
- What are the specifications of the Activated carbon and Bio oil should be?
- In how much quantity raw material will be required?
- Which steps to be followed for production of Activated Carbon and Bio oil?
- How much quantity of land, man, machine will be required?

These are the important points which are to be taken into consideration before establishing an industry. Also as we are establishing an industry so the main objective of it should be customer satisfaction and profit to be earn.





2. LITERATURE REVIEW

The main purpose of this literature review is to know about the project from reference books, journals, technical papers and web sites.

(Susheela.P, Radha.R) (IJCBS RESEARCH PAPER VOL. 1 [ISSUE 10] JANUARY, 2015): This paper shows that Activated carbon is a non-graphite form of carbon which could be produced from any carbonaceous material. Activated carbons are increasingly used as the economic and stable mass separation agent for the removal of surfactants to raise the final product quality many industrial processes. Activated carbons also play an important role in many areas of modern science and technology such as purification of liquids and gases, separation of mixtures and catalysis. The main objective of the study is to produce activated carbon from dry coconut shell and to treat the domestic waste water and to recycle the treated water for home gardens. The higher purity, negative cost, high rate of production and strong carbonaceous structure of coconut shell proves to be a precursor for carbon production. This research will pave way for the recycle and reuse of waste water that could further reduce the level of water pollution.

(Rahul G Karmankar) (IRJET VOL. 3 Issue 01-Jan-2016): This papers show the carbon black and its manufacturing process. Carbon black is produced by the incomplete combustion of hydrocarbon or thermal cracking. The black falls into three groups by method of manufacture: (1) channel (2) furnace, and (3) thermal. The average particle size of black ranges from about 15 - 275 millimicron. The finest black is channel black and coarsest is the thermal blacks, but there is some overlapping of the furnace blacks at both ends. Carbon blacks are not pure carbon but contain varying amounts of hydrogen and oxygen. The principal effect of this non-carbon material seems to be on the surface characteristics, specially the pH. The channel blacks are acid, while furnace blacks and thermal blacks are neutral or alkaline. The acid blacks are slower curing and generally require more accelerators for good cure. As a group, the carbon blacks have probably received the greatest amount of study both as to method of manufacture Carbonization (or

carbonization) is the term for the conversion of an organic substance into carbon or a carbon-containing residue through pyrolysis or destructive distillation. The soot of a natural gas flame, used in paints; is fine carbon. Also called channel black.

(Dipa Das, Debi Prasad Samal): Adsorption has appeared as one of the promising methods for CO₂ capture and sequestration due to its low energy consumption, cost effectiveness, relatively simple technological process, non-corrosive to the equipments and it is applicable over a relatively wide range of temperatures and pressures. Development of new and high efficient solid adsorbents is crucial to enhance competitiveness of this process. Zeolites or activated carbons are good adsorbents that are used for capturing CO₂ from flue gas through physical adsorption, due to its porous structure. The extensive use of activated carbon is used now days, due to its large micro porosity, large specific surface area. The activated carbon is seems to be black in color and have large micro porosity. Activated carbon adsorption also used for treating low concentrations of wastewater streams at extremely low cost. The removal efficiency of Activated carbon is very high for harmful pollutants. As environmental pollution is the major problem now a day's so need of activated carbon is growing day by day. Its texture characteristics and surface properties depend on the raw material and on the method used for its preparation. For AC, the removal of moisture is not required and it is easy for regeneration and has a high CO₂ adsorption capacity at ambient pressure and also its good adsorption properties. Activated carbons can be prepared by either a physical method or chemical method. It is produced from a large number of carbonaceous raw materials like coal, lignite, wood and some agricultural product like rice husk, nut shell, coconut shell, pea nut, sugarcane bagassage, tamarind wood, saw dust and industrial waste products. The cost of Agricultural wastes is very low so it is considered to be a very important feedstock for preparation of AC. To prepare activated carbon from chemical activation, the steps are carbonization step and activation step. Raw material is impregnated with an activating reagent before carbonization step in chemical activation method. The effect of different chemical reagents on the production and quality of activated carbon was studied extensively by different researchers.

(Radhakrishnan C, Karunaraja Natarajan Azhagendran K, Mohanlal K, Ponraj P, Nivas R): The utilization of biomass materials as a renewable energy sources is attracting the global attention over the last two decades and this is much more predominant in countries where agricultural activities are abundant. A continuous type pilot plant for the production of bio-char and the down-stream products (bio-oil and synthesis gas) was designed, developed and

analyzed. The pilot plant consists mainly of a rotary pyrolysis reactor, cyclone separator and a condenser assembly. Heating is done externally underneath the retort using an LPG stove, having provision for controlling the heating rate. The generated bio-oil is directly condensed in water condenser method. Experiments were conducted with different types of bio-masses, varying the residence times and pyrolysis temperatures. The recoveries of bio-oil products obtained under different treatment conditions along with their characterizations are reported.

3. MARKET SURVEY

Activated carbon comes in forms such as granular, powdered, and pellets. The type of activated carbon used for water purification applications in Municipal Corporations and Municipal Councils and also Rite Water Solutions Pvt. Ltd. (Water purification Industry) is powdered activated carbon (PAC). The price for powdered activated carbon at 97% purity is Rs.35 per kilogram.

Along with the activated carbon, the plant sells bio-oils. Since the bio-oils are in their crude state, they are sold at Rs.20 per kg. Bio-oils can be used as a fuel source or can be further used as furnace oil. Construction of this plant is highly recommended.

The various market requirements are as follows:

1. Activated carbon:

Market Place	Requirement (kg/month)
Nagpur Municipal Corporation	18000
Amaravti Municipal Corporation	16000
Akola Municipal Corporation	18000
Chandrapur Municipal Corporation	16000
Wardha Municipal Council	13000
Gondia Municipal Council	13000
Bhandara Municipal Council	9000
Washim Municipal Council	9000
Yavatmal Municipal Council	9000
Gadchiroli Municipal Council	8000
Rite water Solutions, Nagpur	1000
Pharmaceutical Industry	20000

2. Bio-Oil:

1. Steel Factory
2. Boiler Factory

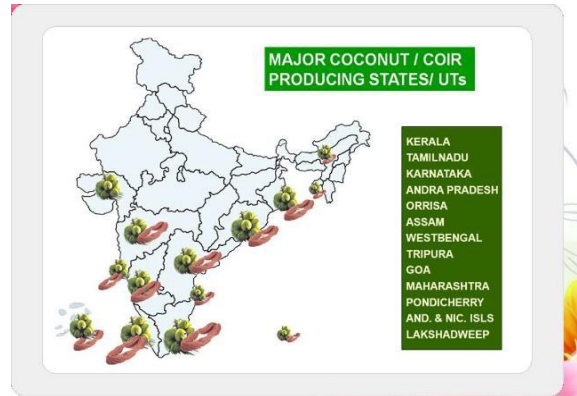

Fig.1: Coconut production in India

Also, as we are considering only Vidarbha region so according to market survey there are production industries of activated carbon and bio-oil from coconut shell in respective region. Only dealers are there of activated carbon and bio-oil.

So, if we establish an industry of activated carbon and bio-oil in Vidarbha region then there will be very less or almost no competition to our industry.

4. BLOCK FLOW DIAGRAMS

a. Pyrolysis process:

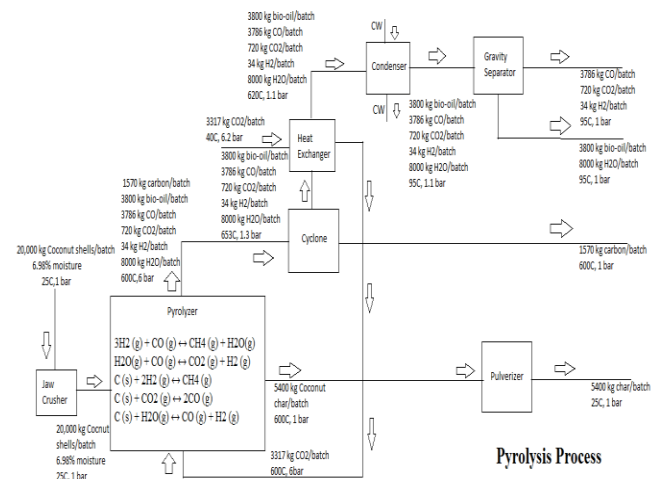

Fig.2: Pyrolysis Process

b. Activation process:

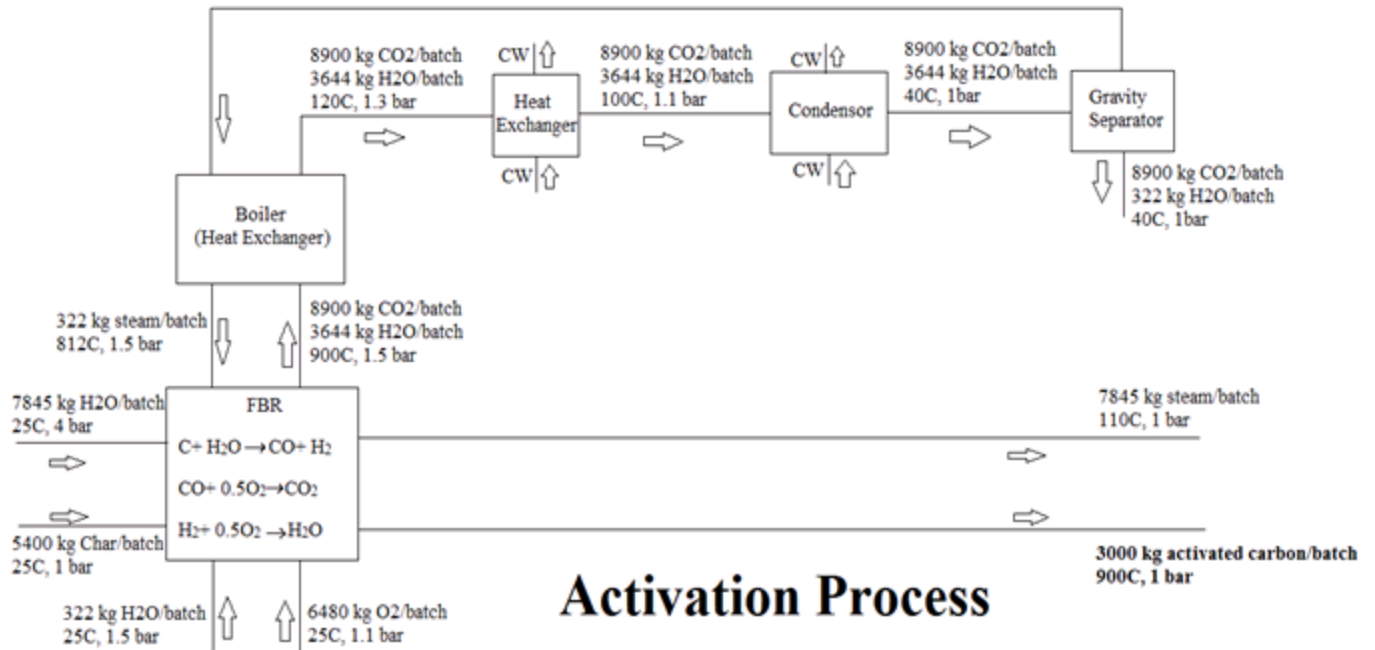

Fig.3: Activation process

5. PROCESS TECHNOLOGY

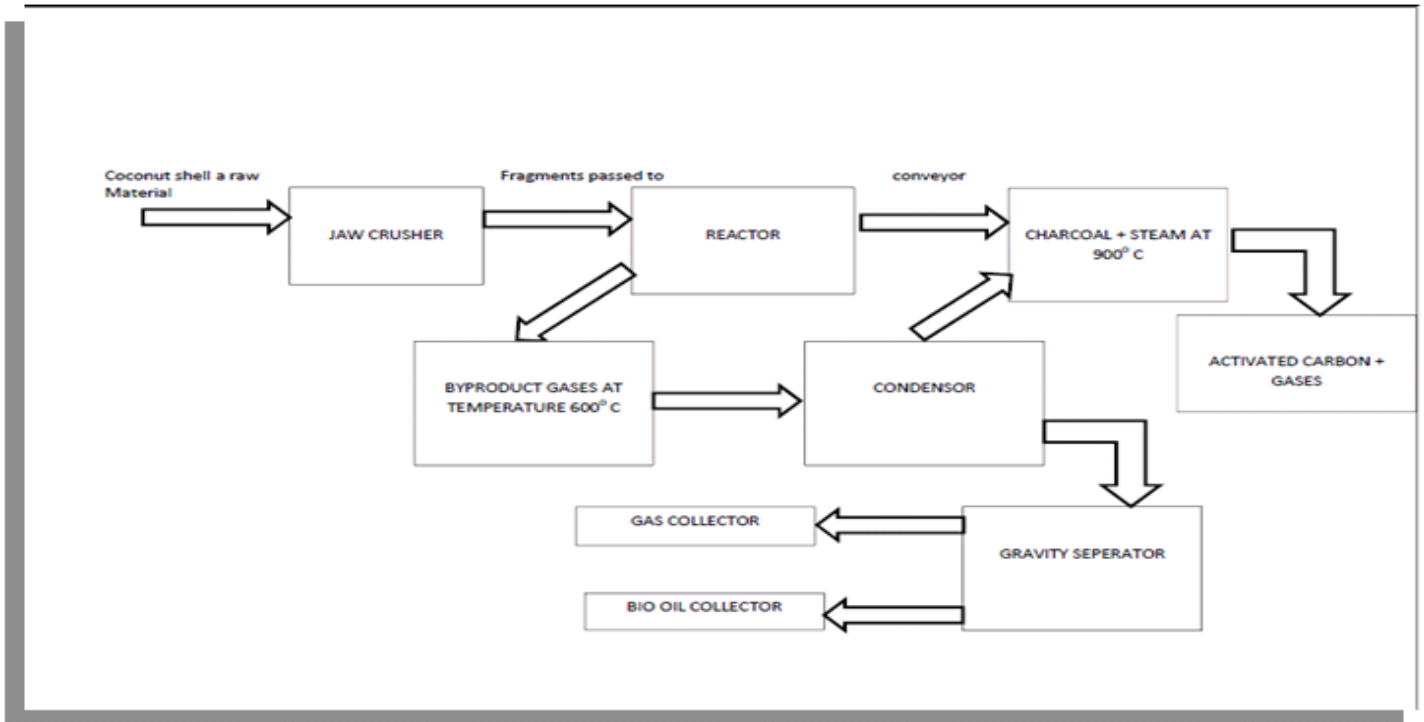

Fig.4: Process Technology

6. TECHNICAL SPECIFICATION

TECHNICAL SPECIFICATION OF GRANULAR ACTIVATED CARBON					
Appearance	Black Granular				
Particle Size	Any sieve size viz. 4 / 8, 8 / 16, 12 / 30, 4 / 16, 8 / 30, 16 / 30				
Iodine Adsorption	500 mg / gm ± 25	750 mg / gm ± 25	850 mg / gm ± 50	950 mg / gm ± 50	1100 mg / gm ± 50
pH	9 to 10	9 to 10	9 to 10	9 to 10	9 to 10
Moisture	5%	5%	5%	5%	5%
Total Surface Area	500 m ² / gm.	750 m ² / gm.	850 m ² / gm.	950 m ² / gm.	1100 m ² / gm.
Bluk Density	0.55 ±0.05 gm. / CC	0.53 ±0.05 gm. / CC	0.51 ±0.05 gm. / CC	0.50 ±0.05 gm. / CC	0.48 ±0.05 gm. / CC
Ball Pan Hardness no.	90	85	80	80	70
Ash Content	5.% Max	5.% Max	5.% Max	5.% Max	5.% Max

Table 1: Technical Specification of Activated Carbon

Technical Specification for bio oil according to American Standard for Testing and Material (ASTM).

Sr. No.	Material Samples	Viscosity @ 40°C Kinematic Dynamic	Calorific Value (Kcal/Kg)	Moisture (%)
1.	Coconut Shell	17.6Cst/s 18.37mPa.s	4456.6	21.3
2.	Coconut Front	17.8Cst/s 18.48mPa.s	4616	23

Table 2: Technical Specification of Bio-oil

7. PROJECT REQUIREMENT & BATCH SIZES

1. Raw Material Requirement:-

- Coconut Shells: 1,000 tonnes of shells/month
- Daily Requirement: 40 tonnes of shells/day

2. Final Production:-

- Activated Carbon: 150 tonnes of Activated Carbon/month
- Bio-oil: 190 tonnes of Bio-oil/month
- Daily Requirement:
 1. Activated Carbon: 6 tonnes production/day
 2. Bio-oil: 8 tonnes production/day

3. Utility Requirement:-

- Electricity: 1,360MW of Electricity/month
- Process Water: 16,280 m³ of Process Water/month
- Fuel: Furnace Oil 100 lit.

4. Batch sizes

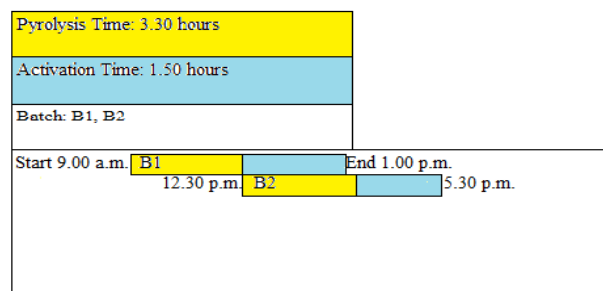

Fig.5: Batch sizes

- 20 tonnes of raw material require per batch and can produce 3 tonnes of activated carbon (15%) and 4 tonnes of bio-oil (19%) per batch approximately.

8. FINANCIAL STATEMENT

A. Variable Cost	Rs. In Lac
Raw material and Utility	54
Spares and Maintenance	2

