

Reactive Power Management Using TSC-TCR

Kumarshanu Chaurasiya¹, Sagar Rajput¹, Sachin Parmar¹, Prof. Abhishek Patel²

¹ Student, Department of Electrical Engineering, Vadodara institute of engineering, Kotambi, Vadodara-390018, Gujarat, India

² Assistant professor, Department of Electrical Engineering, Vadodara institute of engineering, Kotambi, Vadodara-390018, Gujarat, India

Abstract - The concept of reactive power management embraces a diverse field of both system and customer problems, especially related with power quality issues, since most of power quality problems can be attenuated or solved with an adequate control of reactive power [3]. Generally, an issue of poor power factor is faced due to the lagging load current when heavy inductive loads are connected to transmission line. Also in some cases, due to minor load, very low current flows through the transmission line results in a leading shunt capacitance in the line causing voltage amplification due to which the receiving end side voltage may become twice of the sending end side voltage (Ferranti effect), in long transmission lines. To prevent occurrence of such an issue, we have a new concept of hybrid reactive power controlling model by using a parallel combination of thyristor controlled reactor (TCR) and thyristor switched capacitor (TSC) as it will automatically provide a smooth current control range from capacitive to inductive values by varying the firing angle of thyristor through microcontroller.

Keywords: Reactive power, Management, FACTS, SVC, TSC-TCR, Arduino.

1. INTRODUCTION

Recently, voltage stability and voltage regulation have received widespread attention because power systems are interconnected to supply loads of large and distant regions. Different types of flexible AC transmission system (FACTS) controllers in AC systems can be used for compensation, voltage control, voltage regulation, voltage stability, controlling the phase angle, varying the line impedance, reactive power control, steady state stability, damping system oscillations, and controlling power flow in the transmission line.

The reactive power requirements increase with the increase in line length. AC lines require shunt and series compensation in long distance transmission mainly to overcome the problems of line charging and stability limitations. The shunt type of FACTS Controllers is used to either absorb or inject reactive power into the system and provides reactive power compensation. Shunt reactors and shunt capacitors are, extensively used for this purpose. With the help of power electronics the power transmission network can be utilized more effectively.

Static VAR Compensators is a shunt type of FACTS device which behaves like a shunt-connected variable reactance, which either generates or absorbs reactive power in order to regulate the PCC voltage magnitude. SVC is based on thyristors without the gate turn-off capability and includes separate equipment for leading and lagging VARs the thyristor-controlled or thyristor switched reactor for absorbing the reactive power and thyristor-switched capacitor for supplying the reactive power by synchronous switching of capacitor banks. In most cases, a combination of both will be the best solution [1], [2].

1.1 Thyristor Switched Capacitor [TSC]

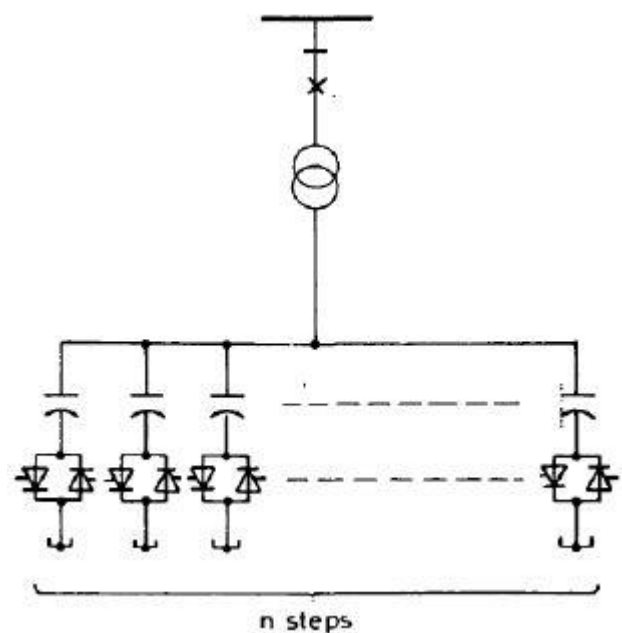

Fig-1: Thyristor-switched capacitor (TSC)

Fig 1 shows the thyristor-switched capacitor (TSC) type of static compensation. The shunt-capacitor bank is split up into small steps, by using bidirectional thyristor switches it can be made switched in and out individually. Fig 2 shows the single-phase branch, consists of capacitor C and the thyristor switch TY and a minor component, the reactor L , which is used to limit the rate of rise of the current through the thyristors and also to prevent resonance with the network. The capacitor is switched out through the suppression of the gate trigger pulses of the thyristors [2].

The capacitor in the stand-by state loses its voltage as it is provided by the resistance R and it is immediately get ready for a new connection, even if it has not been completely discharged.

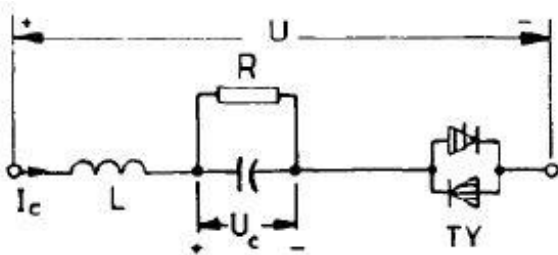

Fig-2: Single branch of TSC

1.2 Thyristor Switched Capacitor [TCR]

A TCR is one of the most important building blocks of thyristor-based SVCs. Although it can be used alone, it is more often employed in conjunction with fixed or thyristor-switched capacitors to provide rapid, continuous control of reactive power over the entire selected lagging-to-leading range. Fig 3 shows the thyristor-controlled reactor (TCR) type of static compensation. Fig 4 shows the single phase TCR branch, which includes an inductor L and a bidirectional thyristor switch TY.

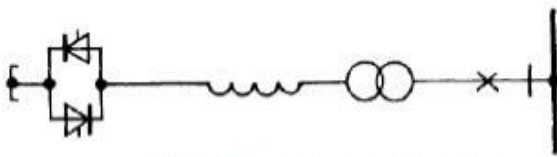

Fig-3: Thyristor-controlled reactor (TCR)

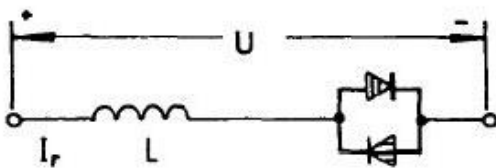

Fig-4: Single branch of TCR

1.3 Combination of TSC-TCR

Fig. 5 shows Combination of both TSC and TCR, which is good reactive power compensation. The choice of product must be the cost effective and also good in quality and in response, which strongly depends on the cost evaluation of the losses [6]. In the thyristor switched capacitor scheme the total reactive power is split into a number of parallel-capacitor banks. The reactive power from the compensator follows the load or terminal voltage variations in a step. A continuously variable reactive power can be achieved by using a thyristor-controlled reactor in combination with thyristor-switched capacitor banks. The harmonic

generation will be low, because the controlled reactor is small compared with the total controlled power [2]. A continuous change in the control order from fully lagging to fully leading current is obtained by TSC- TCR combination. The operation of the controlled reactor is in perfect co-ordination with the switched-capacitor banks.

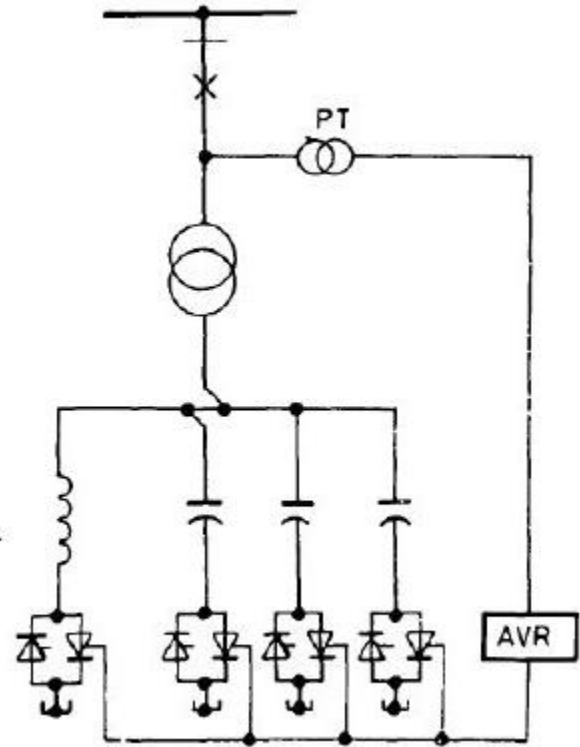

Fig-5: Combination of TSC-TCR

2. COMPARISON

Table -1: Comparison of SVCs

Compensator or Type	Positive Characteristic	Negative Characteristic
TSC	Stepwise control. Very low inrush transients. No generation of harmonics. Low losses at low compensator reactive-power output.	Average delay of one half-cycle in the execution of a command from the regulator, as seen for a single phase.
TCR	Continuous control. Practically no transients. Maximum delay of one half cycles in the execution of a command from the regulator, as seen for a single phase.	Generation of harmonics.
TSC-TCR	Continuous control. Practically no transients. Low losses. Flexibility in control and operation.	Low generation of harmonics.

Table-1 shows the comparison among various SVCs available, the main motivation in developing TSC-TCRs is for enhancing the operational flexibility of the compensator during large disturbances and for reducing the steady-state losses. It is evident that there is no single SVC that acts as a universal remedy for all reactive-power compensation requirements. The choice of a specific SVC is based on several considerations—the application requirement, speed of response, frequency of operation, losses, capital cost, and so forth. Nevertheless, the TSC-TCR is by far the most versatile among all SVC configurations, even though with a cost premium.

3. BLOCK DIAGRAM

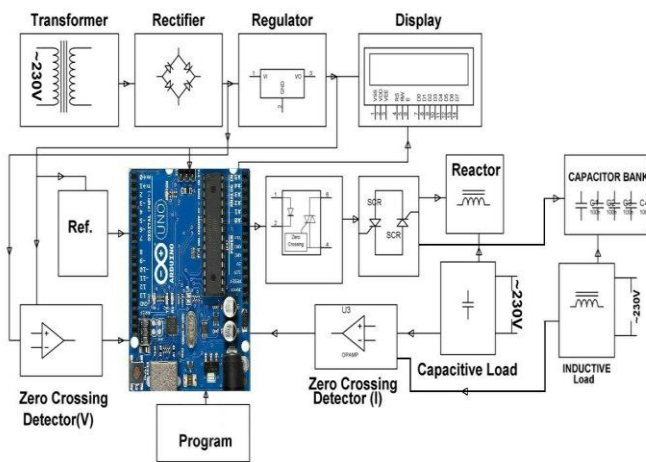

Fig-6: Block Diagram

The operation of the TSC-TCR type SVC can be controlled using an Arduino controller, 8051 or PIC controller. This project model uses Arduino UNO as the main controller of the whole system. The operation and control of the TSC-TCR are performed by the Arduino. Our purpose is to minimize reactive power flow from source with the help of proper triggering of thyristor values in TCR and switching of TSC. The above Block diagram represents the basic layout of components to be used in our project for compensation of reactive power. We have used Arduino UNO as the main controller. The supply of 5V to the Arduino is given by a source i.e. power bank or by step-down transformer supply rectified to 5V DC. All the components which are used for the different operation of the train are connected to the Arduino328.

A step-down transformer voltage can be converted into 5V dc using bridge circuit. A block of Zero crossing detector circuits using an opto-coupler is to measure lead or lag time difference between voltage & current. In this proposed system the lead time between the zero voltage pulse and zero current pulse duly generated by suitable ZCD are fed to two analog pins of Arduino, which measures the respective power factor

Further the TSC & TCR blocks are represented which will absorb or generate the reactive power as per requirement for the balance transmission system. The program takes over to bring the shunt reactors or shunt capacitance to the circuit to compensate the reactive power. Back to back SCRs duly interfaced through optical isolation from the programmed Arduino are used in series for switching the reactor or capacitor.

The loads are connected to vary the power factor lagging or leading and observe the functioning of the TSC & TCR for the improvement of power factor.

4. CIRCUIT DIAGRAM

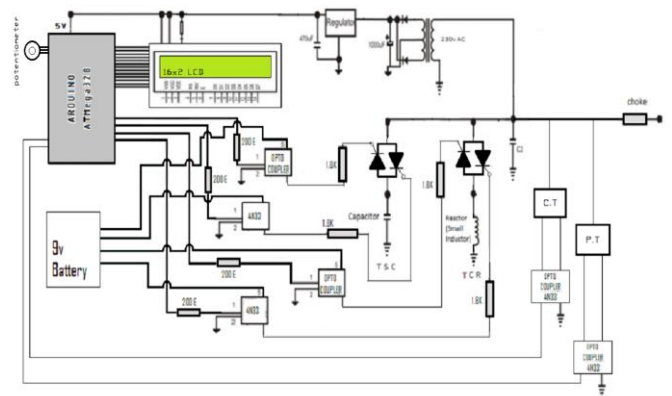

Fig-7: Circuit Diagram

The main function of our project is to improve power factor, maintain voltage above describe limit & increase reliability, stability of the system. For doing this it consist of several components as shown in fig. 7. It consists of a 100mH inductance connected to 1-ph supply which serves as a line inductance of the transmission line in our project. After which two CT (3A/300mA) & two PT (230/9V) are connected in series & parallel respectively with phase & neutral as shown in fig. 7. The Reactor & capacitor are connected between phase & neutral with two thyristor in anti parallel manner for both reactor & capacitor. Then the load is connected to the circuit.

The main requirement of CT & PT is to measure power factor, voltage & current. One CT is connected two rectifier which convert ac to dc, capacitor of 1000µF, 25V is connected across it to filter the DC then after the resistance of 10ohm is connected to convert current signal into voltage signal & given to the Arduino analog pin A1. This is used as the measurement of the current. As same for voltage, Output of any one PT is connected to rectifier then capacitor then to voltage divider circuit of 10Kohm resistor to the Arduino analog pin A0. For power factor measurement remaining CT & PT outputs are taken. The output of the CT & PT is connected across ZCD, which produce output of square wave for each positive half cycle. This output of ZCD of CT & PT is connected to digital pins 6 & 7 respectively and for

displaying purpose LCD is connected to the Arduino pins 8, 9, 10, 11, 12, 13 (D7, D6, D5, D4, En, Rs). Arduino measures the voltage, current by taking samples at various times & display it on LCD. By comparing the square wave of ZCD of CT & PT Arduino calculate the power factor & display it on the LCD.

The main circuit consists of four thyristors, two connected to reactor & another two to the capacitor. For driving the thyristor gate driving circuit is used which is made using IC4N33. This gate driving circuits input is connected to Arduino & output is connected between gate & cathode of thyristor. Two thyristor of capacitors is switched by the Arduino pins 5 & 4. For controlling the reactor the two thyristor of inductor is connected to the Arduino pins 3 & 2. For controlling the firing angle potentiometer is connected to the analog pin A2 of Arduino. As the potentiometer value is changed the firing of thyristor of reactor is changed. We had used lamp load of 200 Watt & one induction motor of 180 Watt, 2.6 Ampere, 1-ph, 230 v AC. Lamp load is directly connected to the phase & neutral of the supply while the motor is connected through the switch.

5. MATLAB SIMULATION

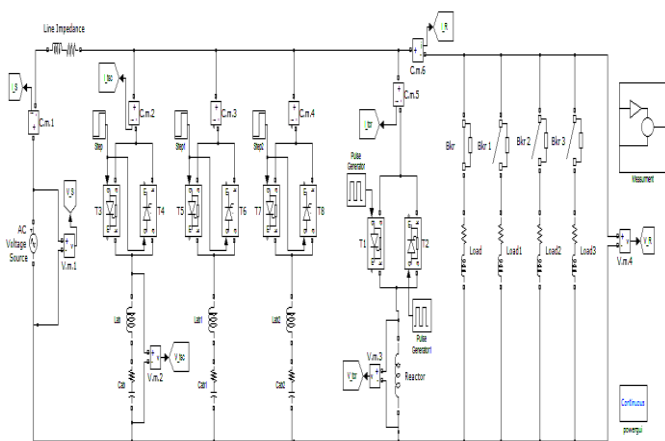

Fig-8: Simulation of 1ph TSC-TCR

6. RESULTS

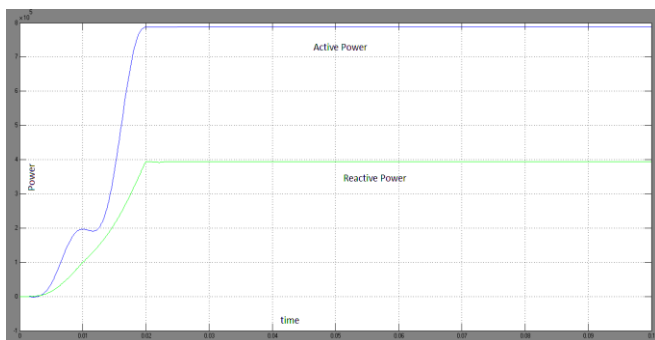

Fig-9: Active & Reactive power without TSC-TCR



Fig-10: Active & Reactive power with TSC-TCR

7. HARDWARE MODEL

The hardware model of 1-ph TSC-TCR is as shown in fig. 11.

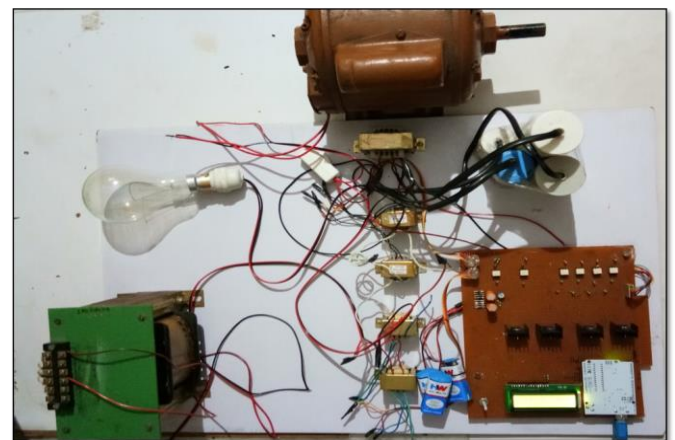

Fig-11: Hardware model of 1ph TSC-TCR

At starting the lamp load is connected to the supply as load, through the line inductance, two CT. The induction motor is in off condition, it is not connected to the supply due to switch in off position. The thyristor switched capacitor is continuously on which compensate the line inductance. The potentiometer will be at maximum position hence the reactor connected to the circuit for minimum time duration. As the load is resistive only, capacitor of TSC compensate the reactive power of line inductance & reactor of TCR is conducted for minimum time duration the power factor displayed on the LCD is near to unity. Exact unity is not possible as only 75% compensation can be done by the capacitor of TSC.

Now we vary the potentiometer, by means decrease the value of the potentiometer the value at which thyristor of the reactor triggers is reduced. As the conduction time of the reactor is increase the power factor will slightly go down. In case of light load condition this type of compensation is done.

During only lamp load the potentiometer is set at minimum level so the time for conduction of the reactor for that period will be maximum. The power factor is nearer to the unity as

the extra capacitive reactive power injection is compensated by the reactor of TCR. Now as the motor is connected to the supply by switching on the switch the motor draws the huge amount reactive power from the supply. The power factor will fall down up to certain level also the voltage goes down. To improve it certain corrective action is taken. The potentiometer is varied & set to its maximum value so the conduction period for the reactor of TCR is minimum. This in turn reduce the net reactive power demand due to the fact that the capacitor of TSC inject the reactive power in circuit& also the reactor of TCR is connected for minimum time duration which reduce reactive power demand of TCR so the voltage is maintained & power factor of the circuit is again improved.

LOAD		TSC-TCR [Firing angle]	Power Factor
LAMP	MOTOR		
ON	OFF	Minimum	0.85
ON	OFF	Maximum	0.95
ON	ON	Minimum	0.89
ON	ON	Maximum	0.95

Fig-12: Results for resistive & inductive loads

8. CONCLUSIONS

In Transmission system frequent load variation is occurred which cause voltage variation at the load-side and sensitive electronics equipment may be damaged. In this paper the importance of reactive power control in transmission line has been studied. Thyristor controlled static compensators can be used for different applications such as, voltage control, voltage balancing and stability improvement. It will be more beneficial to implement it in industries, distribution and transmission systems. In an uncompensated power system the supply voltage decreases with an increase of load. Due to the rise of reactive power demand the power factor decreases with the load. Hence by TSC-TCR which had been attuned to the arising load, a successful compensation was reached with a power factor near to unity.

REFERENCES

[1] R. Jayabarathi, M .R Sindhu, N. Devarajan , And T. N. P. Nambiar, " Development Of A Laboratory Model Of Hybrid Static Var Compensator." 0-7803-9525-5/06/\$20.00© 2006 IEEE.

[2] S. Torseng, Dr. Tech., " Shunt-Connected Reactors And Capacitors Controlled By Thyristors." IEE Proc, Vol.128, Pt. C, No. 6, November 1981.

[3] Chaudhari Krunal R, Prof. Rajesh Prasad "A Transient Free Novel Control Technique for Reactive Power Compensation using Thyristor Switched Capacitor." International Journal of Emerging Technology & Advances Engineering, ISSN: 2321- 9939, Volume – 2 Issue - 1, 2014.

[4] "Thyristor based facts controllers for electrical transmission systems" by R. Mohan Mathur, Ontario Power Generation Toronto, ON, Canada & Rajiv K. Varma Indian Institute of Technology Kanpur, India

[5] T. J. Miller, "Reactive power Control in Electric Systems," John Willey & Sons, 1982.

[6] M. Arunachalam R. Rajan Bahu Bhaskar Bose Dipak Dutta, " Evaluation of Losses in Thyristor Valve For Svc Application." 0-7803-2795-0@2005.