

# AUTOMATIC LOAD BALANCING AND PHASE BALANCING BY PLC AND SCADA

Aishwarya Diwane<sup>1</sup>, Komal Bhalerao<sup>2</sup>, Atul jhadhav<sup>3</sup>, Rajashree S. Kadam<sup>4</sup>

<sup>1,2,3</sup> Diploma students, Department of Electrical Engineering, Guru Gobind Singh Polytechnic, Nashik Maharashtra, India

<sup>4</sup>Assistant Professor, Department of Electrical engineering, Guru Gobind Singh Polytechnic, Nasik, Maharashtra, India

\*\*\*

**Abstract** -In the industries worldwide, the plants need to be shed in order to meet with the supply and often this results in a "not up to the standard" batch of the good. This happens because of care not being taken in shedding the loads, at times switching off essential loads or mistiming the shedding. Shedding is inevitable because if the loads are not shed then all will turn off eventually due to lack of supply. To overcome this problem non-essential loads are often shed following a certain scheme developed after thorough understanding of the product in production. The idea behind the project is to build an automatic load shedding system with the help of a PLC, which actually comes in action in the event of generator tripping and sheds off non-essential loads (as defined by the plant engineers) thereby restoring the balance between the consumption and generation.

**Keywords:** Automatic phase balancing, Fault detection Relay Switching, PLC, SCADA.

## 1 INTRODUCTION

Demand of electricity increases day by day due to requirement of consumers. As population increases demand of electricity increases. Smart electrical grids require, Large interest in electrical load distribution balancing problem. This problem is being not having a solution for large scale system, where the number of single phase consumer connected to three phase system in very large scale in electrical distribution system.

This paper represents a system which required new control technique for automatic phase change, when load on any one phase increases.? In united state electricity mainly travels as AC power. It required three separate wires (i.e R, Y, B) and neutral wire to transmit and distribute the electricity and for grounding protection the additional wire is used. Each of the live wires called as phase as it enters our home, business, residential, commercial, and industrial purpose. There is causes of short circuit is overcurrent, overvoltage, phase difference, fluctuation in supply voltage, imbalanced load. Due to this

### 1.1 Proposed System

SCADA based system is Employed for proper functioning of individual systems and also for the communication between them in these processes there is a dedicated PLC

that Performs data logging and control operations. Important concept of the SCADA based system is that each system can function independent of each other and hence other systems can be Shut of when not in use.

The paper provides a good communication of Implementations in creating a PLC based unit and usage of an advanced graphical user interface in process control. This system replaces large control panels.

### 1.2 Objective

- The main objective of our project is While running on multiple sources, there could be an event of one or more sources going down and this could result in overloading of the other running sources.
- A Human Machine Interface (HMI) is also to be developed for this system which helps the engineers on the plant to monitor the process and make tweaks in the priority list.
- In normal operating conditions, power system equipment or lines carry nominal voltages and currents which results in an accurate and good operation of the system.

### 1.3 Motivation

This system has been designed in a way that all the industries working on multiple power sources can use this on their plants to manage shedding in events of tripping hence keeping the plant in normal operation. Scope of The Project with the ongoing state of energy crisis worldwide and especially in Pakistan, industries are often at the mercy of the local utility supplies or power distribution authorities. This is due to the fact that there exists a short fall between the demand and supply of electric power. Therefore, most industries prefer to operate on generators along with the local utility supply. In case of tripping, loads at the plant need to be shed in order to meet with the supply, and often, this results in a "not up to the standard" batch of the good. This happens because of care not being taken in shedding the loads, by switching off essential loads, or mistiming the shedding. Shedding is vital because if the loads are not shed then all will shut down eventually due to lack of supply. To overcome this problem, non-

essential loads are often shed following a certain scheme developed after thorough understanding of the product in production.

## 2 IMPLEMENTATION OF SYSTEM

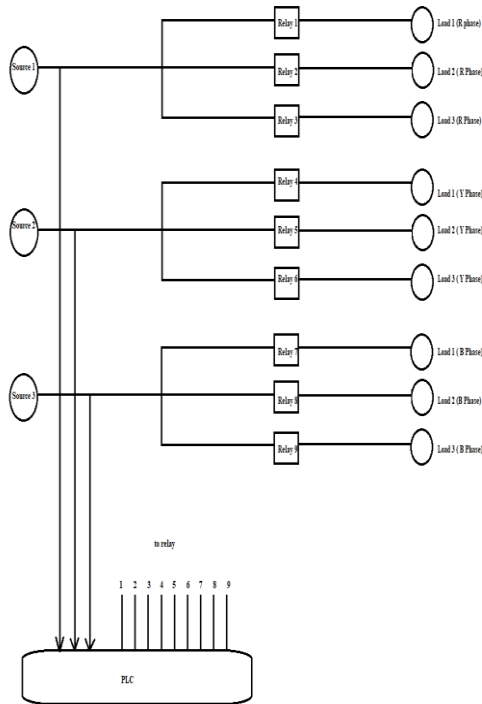

Fig No 1 Block Diagram

## 3 PLC

The key difference of PLC with other general purpose computers is that PLCs are robust and are prone to severe conditions of moisture, cold, dust & heat and have the provision for extendable input output arrangements. These are then used to connect the controller with sensors and actuators. At the sensor (input) side, the PLC reads analog process variables (pressure and temperature), limit switches, and the positions of complex positioning systems. Whereas, on the actuator (output) side, PLCs operate relays, electric motors, solenoids, hydraulic or pneumatic cylinders as well as analog outputs often with an isolating opto-coupler in between for added protection. Scan Cycle Length The controlling algorithm normally executes repeatedly for as long as the process in running and the plant is in operation. The physical condition or the current status of the inputs is stored on the memory in form of a table normally referred to as "I/O Image Table". The program then runs from the first scene to the last instruction one by one. The processor then makes changes to the outputs on the basis of the latest fetched values of the inputs and the running algorithm. But these changes require some time to come in effect counting from the beginning of the scan cycle. This may be a few milliseconds for a short code and a speedy processor, but older PLCs running very large programs require.

Literature Review more time and may near 100ms per run cycle. The higher this duration is, the more meaningless the output becomes. With the passage of time, things changed and new technologies started appearing of the face of earth. So was the fate of PLC systems. More advanced techniques were fashioned to reform the execution of ladder programs. This happened in the shape of subroutines.

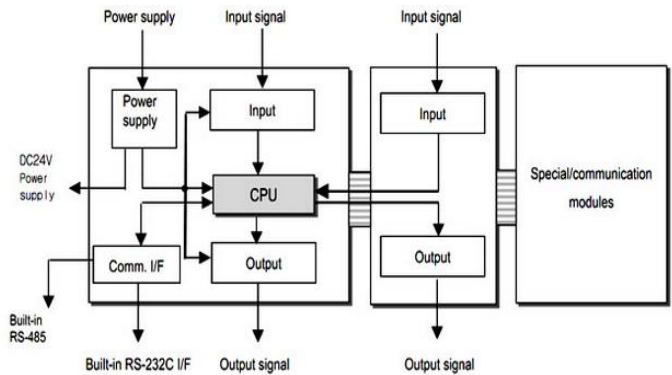

Fig No 2 Block Diagram of PLC

### 3.1 Allen-Bradley PLC

In recent years "safety" PLCs have started to become popular, either as standalone models or as functionality and safety-rated hardware added to existing controller architectures (Allen-Bradley Guardlogix, Siemens F-series etc.). These differ from conventional PLC types as being suitable for use in safety-critical applications for which PLCs have traditionally been supplemented with hard-wired safety relays. For example, a safety PLC might be used to control access to a robot cell with trapped-key access, or perhaps to manage the shutdown response to an emergency stop on a conveyor production line. Such PLCs typically have a restricted regular instruction set augmented with safety-specific instructions designed to interface with emergency stops, light screens, and so forth. The flexibility that such systems offer has resulted in rapid growth of demand for these controllers.



Fig No 3 Allen-Bradley PLC installed in a control panel

## 4 SCADA

Supervisory control and data acquisition (SCADA) is a control system architecture that uses computers, networked data communications and graphical user interfaces for high-level process supervisory management, but uses other peripheral devices such as programmable logic controllers and discrete PID controllers to interface to the process plant or machinery. The operator interfaces which enable monitoring and the issuing of process commands, such as controller set point changes, are handled through the SCADA computer system. However, the real-time control logic or controller calculations are performed by networked modules which connect to the field sensors and actuators.

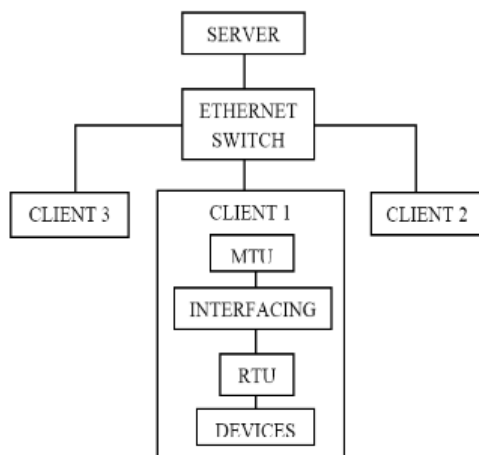

Fig No 4 SCADA

### 4.1 Master Terminal Units (MTU)

Master terminal units (MTU) in SCADA system is a device that issues the commands to the Remote Terminal Unit (RTUs) which are located at remote places from the control, gathers the required data, stores the information, and process the information and display the information in the form of pictures, curves and tables to human interface and helps to take control decisions. This is the operation of the Master Terminal Unit (MTU) located in the control center.

### 4.2 Remote Terminal Unit (RTU)

A remote terminal unit (RTU) is a microprocessor-controlled electronic device that interfaces objects in the physical world to a distributed control system or SCADA (supervisory control and data acquisition) system by transmitting telemetry data to a master system, and by using messages from the master supervisory.

### 4.3 Interface

Mostly Industrial Ethernet or profane are used for the communication. So first assign PLC IP address and then

SCADA server IP address in which SCADA runtime is installed.

### 4.4 Intelligent Electronic Devices (IEDs)

A DNP3 IED is a SCADA system component. The role of the DNP3 IED is to collect information from sensors and power equipment within SCADA operations. This is most commonly in water and power utilities. Some DNP3 IED's are also capable of issuing equipment-controlling commands.

## 5 SIMULATION TOOLS

Ladder logic was originally a written method to document the design and construction of relay racks as used in manufacturing and process control.<sup>[1]</sup> Each device in the relay rack would be represented by a symbol on the ladder diagram with connections between those devices shown. In addition, other items external to the relay rack such as pumps, heaters, and so forth would also be shown on the ladder diagram. Ladder logic has evolved into a programming language that represents a program by a graphical diagram based on the circuit diagrams of relay logic hardware. Ladder logic is used to develop software for programmable logic controllers (PLCs) used in industrial control applications. The name is based on the observation that programs in this language resemble ladders, with two vertical rails and a series of horizontal rungs between them. While ladder diagrams were once the only available notation for recording programmable controller programs, today other forms are standardized in IEC 61131-3.

## 6 ADVANTAGES

- This system is used for reduce overload condition.
- This system is used reduce fault like over current, over voltage etc.
- This system is safe for electrical networks.
- Over current in phase is reduce.
- Switching speed is high.
- Failure rate is less due to PLC.
- Unbalancing problem is reducing.

## 7 CONCLUSIONS

This project is implementable in a lot of industries using multiple sources of power. The system will make sure that in the case of tripping of a generator, the entire plant does not shut down. This can help avoid a lot of losses like raw material, machines and most importantly valuable time. Since the action in this event is required to be quick, an automatic system is the most suitable rather than a human personnel shedding the loads. The trending feature can help to avoid these events in the future and the feature of alarm logging is useful because it tells which generator has gone off and what loads are shed in the reaction. This

information can then be passed on to the engineers for quick rectification. Also, the flexibility in the priority list can account for different priorities at different times. This is required because the manufacturing is often dependent on the seasons and other such factors.

## 8 FUTURE SCOPES

- The modifications to be done in this project are addition of voltage sensor or voltage comparator to detect voltage fault or fluctuation in transmission line.
- This system can be more accurate in term of timing and data recording with the help of PLC.
- We can use GSM module to receive information.
- This system can be used in DC parameter fault analysis.

## ACKNOWLEDGEMENTS

Sincere thanks to all the anonymous researchers for providing such a useful and helpful opinion, findings, conclusions and recommendations. Also gives immense pleasure to thanks to guide Ms. Rajashree Kadam, HOD Prof. S.M. More, Principal P.S. Duggal and friends for their kind support and guidance.

## REFERENCES

1. Gasperic S. - Energy losses in low voltage distribution network, in Energetics (IYCE), Proceedings of the 2011 3rd International Youth Conference on, 2011.
2. Guang Y. and Tao H. "Circuit loss analysis and application development of three-phase unbalanced load of low voltage distribution network" in Electricity Distribution (CICED), 2010 China International Conference.
3. Stojanovic D.P., Korunovic L.M., and Jovic A. - "Measurement and analysis of neutral conductor current in low voltage distribution network" in IEEE EUROCON 2009
4. Desmet J. and Delaere G. - "Harmonics Selection and Rating of Transformers" LPQI (2005).
5. Dugan R. C., McGranaghan M. F., Santoso S. and Beaty H. W. - "Electrical Power Systems Quality" McGraw-Hill, 2002.
6. www.google.com
7. https://m.indiamart.com
8. www.electrical4u.com
9. www.dgvcl.com
10. www.electricaltechnology.org
11. Wikipedia
12. Refereance by MECB officer (Mr. Rajendra pingale)