

Waste Management System Based On IoT

Sapna Suryawanshi¹, Rohini Bhuse², Megha Gite³, Dhanashri Hande⁴

^{1,2,3,4} Department of Information Technology, Matoshri Collage of Engineering & Reasearch Centre Eklahare, Nashik, India

Abstract - Waste management is one of the primary problem that the world faces irrespective of the case of developed or developing country. The key issue in the waste management is that the garbage bin at public places gets overflowed well in advance before the commencement of the next cleaning process. It in turn leads to various hazards such as bad odor & ugliness to that place which may be the root cause for spread of various diseases. To avoid all such hazardous scenario and maintain public cleanliness and health this work is mounted on a smart garbage system. The main theme of the work is to develop a smart intelligent garbage alert system for a proper garbage management. This paper proposes a smart alert system for garbage clearance by giving an alert signal to the municipal web server for instant cleaning of dustbin with proper verification based on level of garbage filling. This process is aided by the ultrasonic sensor which is interfaced with Arduino UNO to check the level of garbage filled in the dustbin and sends the alert to the municipal web server once if garbage is filled. After cleaning the dustbin, the driver confirms the task of emptying the garbage with the aid of RFID Tag. RFID is a computing technology that is used for verification process and in addition, it also enhances the smart garbage alert system by providing automatic identification of garbage filled in the dustbin and sends the status of clean-up to the server affirming that the work is done. The whole process is upheld by an embedded module integrated with RF ID and IOT Facilitation. The real time status of how waste collection is being done could be monitored and followed up by the municipality authority with the aid of this system. In addition to this the necessary remedial / alternate measures could be adapted. An Android application is developed and linked to a web server to intimate the alerts from the microcontroller to the urban office and to perform the remote monitoring of the cleaning process, done by the workers, thereby reducing the manual process of monitoring and verification. The notifications are sent to the Android application using Wi-Fi module.

Key Words: e-Monitoring, Arduino UNO, Wi-Fi, Ultrasonic Sensor, GPS, Internet of things (IoT), Waste Management.

1. INTRODUCTION

The generation and disposal of waste in large quantities has created a greater concern over time for the world which is adversely affecting the human lives and environmental conditions. [1]. Wastes are the one which grows with the growth of the country. Segregation of waste is important for proper disposal of vast amount of garbage modern society

produces in an environmentally sensible mode. People became adapted to tossing things away and never realize the consequences of their action. The common method of disposal of the industrial waste is by uncontrolled and unplanned, and exposed dumping at the river sites and open areas. This method is injurious to plants, human health and animal life.

Curb side collection is the most common method of disposal in most countries, in which waste is collected at regular intervals by specialized trucks. Waste collected is then transported to an appropriate disposal area. Now days, cities with developing economies experience exhausted waste collection services, in adequately manage dandun controlled dump site sand the problems are worsening [2]. Waste collection method in such countries is an ongoing challenge and many struggle due to weak institutions and rapid urbanization. At present, the volume of generation of municipal solid waste (MSW) is increasing very highly with the increase of population, economic uprising, industrial development, change in consumption habit and life style of urban population. It became a great challenge to manage MSW to the authorities in charge for waste management. Due to the lack of proper management solution, a considerable amount of 85% of the total MSW management budget is exhausted on waste collection and transportation. As a result, the improvement of the solid waste management system is much needed in recent time which requires a well-organized and proper way to monitor the status of solid waste bin in real time whereas confirming green environment and viable advance of the society.

Smart cities have been identified as a promising potential application domain for the Internet of Things, with a wide range of possible services that can benefit city administration and citizens alike. One service that can be provided in a smart city is smart waste management. Public trash cans detract from the surrounding environment when they are full for long period soft time. On the other hand, it can be an expensive operation to send garbage truck to every trash can in the city; if cans are empty, the journey accomplishes nothing. Cities develop rough algorithms for minimizing cost of various municipal services such as collecting trash, but Internet of Things sensors can improve the services by notifying relevant public works officials when particular trash cans are full.

1.1. PROBLEM STATEMENT

Instead of using plenty of bins in an unordered fashion around the city, we can have minimal no. of smart bins that can be placed that are feasible and affordable. As we have seen all around us, the dustbins are getting overflowed and concerned municipal authorities usually don't get information within the stimulated time.

1.2 METHODOLOGY

Ultrasonic Sensor:

The sensor is used to detect the level of the dust in the dustbin. It uses a sound transmitter and receiver. An ultrasonic sensor creates an ultrasonic pulse called ping and listens for the reflection of pulse. The sound pulse is created electronically using a sonar projector consisting of signal generator, power amplifier, and electro-acoustic transducer array. A beam former is usually employed to concentrate the acoustic power into the beam.

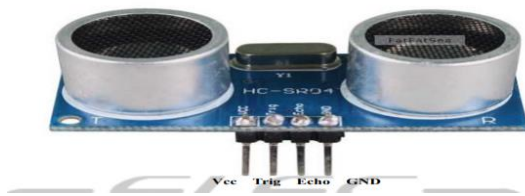

Ultrasonic sensor module consists of 4 pins:

VCC - 5V of power supply

TRIG - Trigger Pin

ECHO - Echo Pin

GND - To ground

3. PROPOSED ETHODOLOGY

While considering the need of technology and innovation, this is not an original idea. The idea has been proposed. But however, we need an original plan for designing a Smart Bins with ultrasonic sensors. Already existing system involves complex circuitry and high costs and features are also limited. In India, if we have a costly garbage bin that will not be a priority experiment for people [3]. Thus here we are deploying such kind of system that is not only cheaper but with extended features that has never been implemented. For detection of trash in the bin, many sensors can be used like weight sensors, IR sensors, etc. But here we are using ultrasonic sensors which gives us directly information about percentage of trash in the dustbins. It is advantageous over weight sensors because weight sensors only tells us about the weight of the garbage, but this does not let us know the level of garbage in the bins. Dynamic Routing and Intelligent Transportation System is a novel solution to the problem

arises with Waste Management [4]. The system will provide high QOS to the citizens of smart city

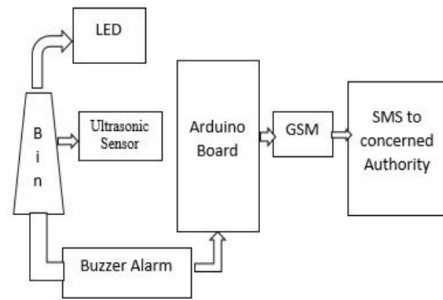
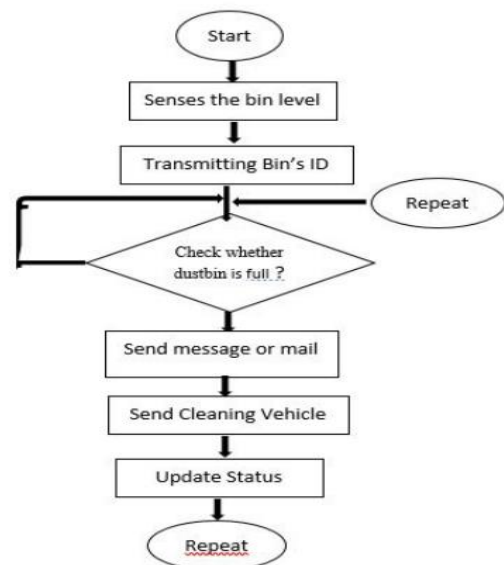

Fig -1: Example of a One-Column figure caption

Flow Chart:-

The flow chart of the project is shown in fig. It basically provides the idea of this project. The flow of the project of smart Waste Management System begins with option start. Ultrasonic sensors are deployed that senses the level of trash in the bins and when it crosses the threshold level, message is sent to the concerned authority via GSM so that the concerned authority can clean the dustbin as soon as possible. The process gets repeat itself again and again until the dustbin is not cleaned.



3. CONCLUSIONS

The objective of the project is for the real time access of information about the dustbin. This waste Management System using IOT has implemented the management of waste in real time using smart dustbin to check the fill level of dustbin to check if it is full or not. The novel cloud-based system for waste collection in smart cities. Providing the services for the different kind of stake holders involved in this area. On-board surveillance cameras and reporting system. Development of application for city administration,

municipality staff. In this information is send and action is taken immediately based on the aspect.

REFERENCES

- [1] D. Eason, B. Noble, and I.N. Sneddon, "On certain integrals of Daniel Hoornweg et al., "what a waste- A Global Review of Solid Waste Management", Urban Development & Local Government Unit World Bank, Washington, DC., No.15, Mar. 2012.
- [2] Social Information and Policy Analysis, United Nations. New York: UN, 1997.
- [3] Kumar, N. Sathish, et al. "IOT based smart garbage alert system using Arduino UNO." [7] Karadimas, Dimitris, et al. "An integrated node for SmartCity applications based on active RFID tags; Use case on waste-bins." Region 10 Conference (TENCON), 2016 IEEE. IEEE, 2016.
- [4] Medvedev, Alexey, et al. "Waste management as an IoT enabled service in smart cities". Conference on Smart Spaces. Springer International Publishing, 2015.

BIOGRAPHIES

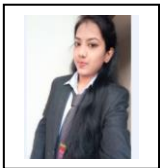

S. D. Suryawanshi is pursuing his BE(Information Technology) from Matoshri College Of Engg And Research Centre, Nashik, Maharashtra, India.



R.V. Bhuse is pursuing his BE(Information Technology) from Matoshri College Of Engg And Research Centre, Nashik, Maharashtra, India. "



M.S. Gite is pursuing his BE(Information Technology) from Matoshri College Of Engg And Research Centre, Nashik, Maharashtra, India. "



D.P. Hande is pursuing his BE(Information Technology) from Matoshri College Of Engg And Research Centre, Nashik, Maharashtra, India. "