

OBSTACLE AVOIDANCE ROBOTIC VEHICLE USING ULTRASONIC SENSOR, ARDUINO CONTROLLER

R.VAIRAVAN [1], S.AJITH KUMAR [2], L.SHABIN ASHIFF[3], C.GODWIN JOSE [4]

^{1,2,3} UG Student, Dept. of Mechanical Engineering, PSN College of Engineering and Technology, Tirunelveli.

⁴ Assistant Professor, Dept. of Mechanical Engineering, PSN College of Engineering and Technology, Tirunelveli.

Abstract - This project describes about an obstacle avoidance robot vehicle which is controlled by ultrasonic sensor. The robot is made using ultrasonic sensor and it is controlled by Arduino microcontroller. Ultrasonic sensor fixed in front portion of the robot vehicle. The sensor gets the data from surrounding area through mounted sensors on the robot. The sensor is sense the obstacle and deviate its path to choose an obstacle free path. The sensor will be send the data to the controller is compared with controller to decide the movement of the robot Wheel. The robot wheel movement and direction will be based on the sensing of the ultrasonic sensor and also using a wheel encoder. This vehicle is used for detecting obstacle and avoiding the collision. We have programmed the controller to be used with ANDROID app.

Key Words: Obstacle, Microcontroller, Ultrasonic sensor, Arduino, Encoder

1.INTRODUCTION

The project is designed to build an obstacle avoidance robotic vehicle using ultrasonic sensors for its movement. An Arduino uno is used to achieve the desired operation. A robot is a machine that can perform task automatically. Robotics is generally a combination of computational intelligence and physical machines (motors). Computational intelligence involves the programmed instructions. The project proposes robotic vehicle that has an intelligence built in it such that it guides itself whenever an obstacle comes ahead of it. This robotic vehicle is built, using an Arduino uno. An ultrasonic sensor is used to detect any obstacle ahead of it and sends a command to the Arduino.

In today's world robotics is a fast growing and interesting field. robot has sufficient intelligence to cover the maximum area of provided space. Autonomous Intelligent Robots are robots that can perform desired tasks in unstructured environments without continuous human guidance. The obstacle detection is primary requirement of this autonomous robot. The robot gets the information from surrounding area through mounted sensors on the robot.

2. SPECIALITIES OF ULTRASOUND TECHNOLOGY

The ultrasonic sensor is one of the best technique which is used for sense for obstacle. The Ultrasonic sensor module "HC-SR04" works on "Echo" concept which is something you get when sound reflects back after reaches the surface. The

travelling time of ultrasonic waves is 343m/s. This much of speed is meticulous for MCU's in microcontroller to measure accurately. Practically the waves reflect back from the surface located 4 meters away in 15 ns. The ultrasonic wave does not affect the humans. The ultrasonic sensor is mostly used for distance measurement application. These sensors are able to detect the barriers present in front of them. Ultrasonic sensors generate sound waves with higher frequencies that humans cannot perceive, making them ideal for quiet environments. They do not consume much electricity, are simple in design, and are relatively inexpensive. The basic block diagram is shown in fig. 1.

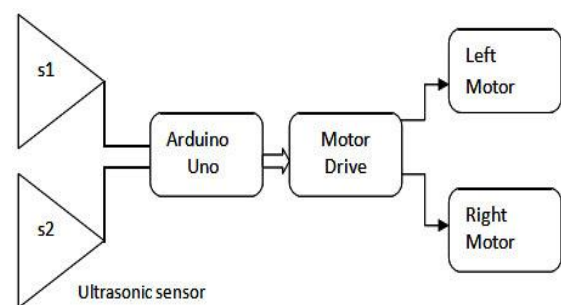

Fig -1: Basic Block diagram

3. SYSTEM DESIGN

In our project the output from the ultrasonic sensor is given to the Arduino uno controller as an input to process them according to codes which are actually embedded into the controller to provide the desired output. The block diagram for the process is shown in Fig.2.

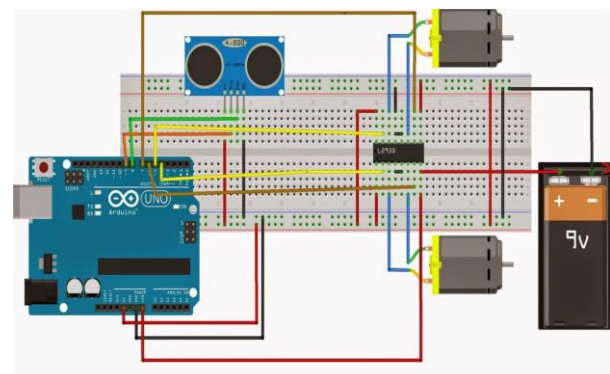

Fig -2:Block diagram of obstacle sensing robot process

3.1. Ultrasonic sensor HC-SR04

The ultrasonic sensor is used for obstacle detection. Ultrasonic sensor transmits the ultrasonic waves from its sensor head and again receives the ultrasonic waves reflected from an object.

There are many application use ultrasonic sensors like instruction alarm system, automatic door openers etc. The ultrasonic sensor is very compact and has a very high performance. It has both the transmitter and receiver. It consists of four pins Vcc pin to offer a 5V supply to the sensor, trigger pin give a TTL pulses (15us), echo pin to get the output from the sensor and ground pin. Ultrasonic sensor HC-SR04 is shown in Fig. 3

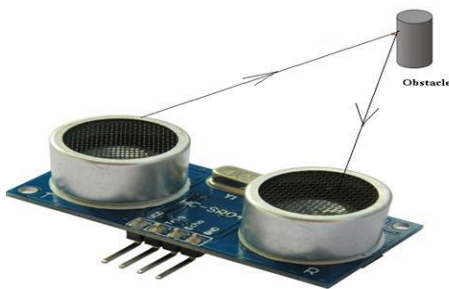

Fig -3:Ultrasonic Sensor HC-SR04

3.2. Timing Diagram

The Timing diagram is shown below in Fig. 4. The ultrasonic sensor emits the short and high frequency signal. These propagate in the air at the velocity of sound. If they hit any object, then they reflect back echo signal to the sensor. The ultrasonic sensor consists of a multi vibrator, fixed to the base. The multi vibrator is combination of a resonator and vibrator. The resonator delivers ultrasonic wave generated by the vibration. The ultrasonic sensor actually consists of two parts; the emitter which produces a 40kHz sound wave and detector detects 40kHz sound wave and sends electrical signal back to the microcontroller.

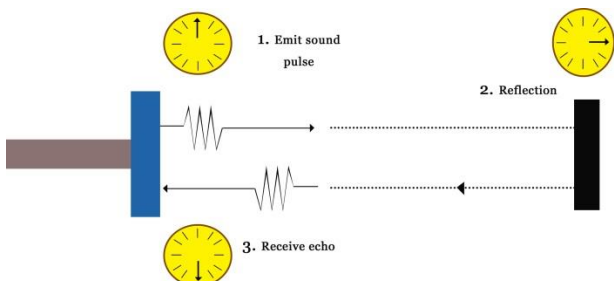

Fig -4:Timing Diagram

4. CIRCUIT DESCRIPTION

The circuit is excited by 9V power supply, the HC-SR04 module is connected to the port A of the 8051series, and the

motor is also connected to the port A via relay switch. The circuit diagram is shown in Fig. 5.

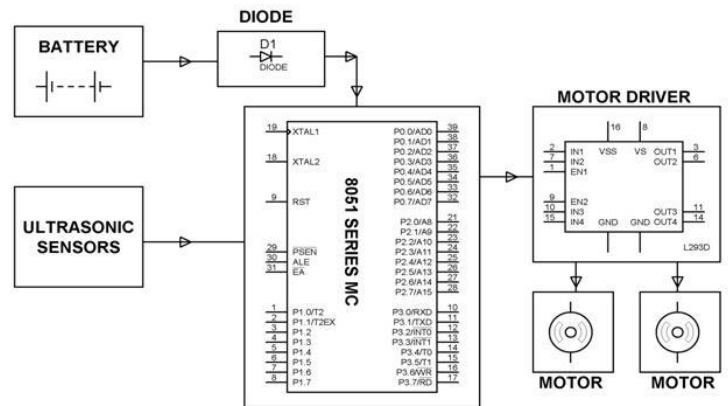

Fig -5: Circuit diagram for ultrasonic sensor and controller using Arduino controller

4.1. MOTOR DRIVE MODULE (L298D)

The L298N H-bridge module can be used with motors that have a voltage of between 5 and 35v dc. With the module used in this tutorial, there is also an onboard 5V regulator, so if your supply voltage is up to 12V you can also source 5V from the board. The Motor drive module diagram as shown in fig. 6

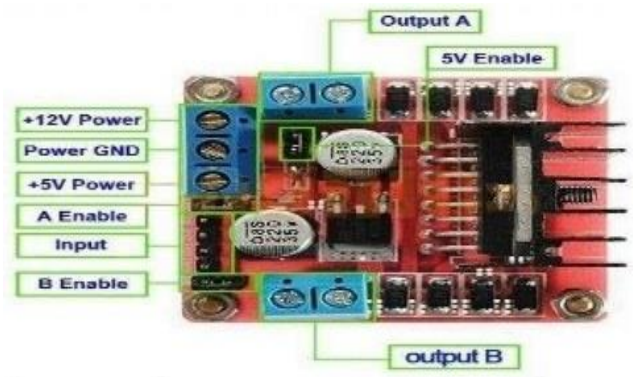

Fig -6: Motor drive module diagram

4.2. CONTROLLING DC MOTORS

H-Bridge L298N module is used to control one or two DC motors is quite easy. First connect each motor to the motor A and B connections on the L298N. If you're using two motors for a robot (etc) ensure that the polarity of the motors is the same on both inputs. Next connect your power supply – the positive to pin 4 on the module and negative/GND to pin 5. If you supply is up to 12V you can leave in the 12V jumper and 5V will be available from pin 6 on the module. This can be fed to your Arduino's 5V pin to power it from the motors power supply. Don't forget to connect Arduino GND to pin 5 on the module as well to complete the circuit.

Now you will need six digital output pins on your Arduino, two of which need to be PWM (pulse – width Modulation) pins. PWM pins are denoted by the tilde (“~”) next to the pin number, for example finally, connect the Arduino digital output pins to the driver module. In our example we have two DC motors, so digital pins D9, D8, D7 and D6 will be connect to the pins IN1, IN2, IN# and IN4 respectively. Then connect D10 to module pin 7 and D5 to module pin 12. The motor direction is controlled by sending a HIGH or LOW signal to the drive for each motor or channel.

However the motors will not turn until a HIGH is set to the enable pin and they can be turned off with a low to the same pin. However if you need to control the speed of the motors, the PWM signal from the digital pin connected to the enable pin can take care of it.

4.3. ORDUINO UNO

Arduino uno is a microcontroller board dased on the ATmega328P(datasheet). It has 14 digital input/output pins of which 6 can be used as PWM outputs, 6 analog inputs, a 16 MHz quartz crystal, a USB connection, a power jack an ICSP header and a reset button

4.3.1. ATMEGA 328P-PU

Atmega328 is a single chip microcontroller created by ATMEL in the mega AUR family A common alternative to the ATmega328 is the “pico power” ATmega328P. The most common implementation of this is on the popular Arduino development platform, namely the Arduino UNO or Arduino Nano models.

4.3.2. Key Parameter

Atmega 328P-PU Key parameters as shown in table. 1

Table -1: Key parameter

PARAMETER	VALUE
CPU type	8-bit AVR
Performance	20 MIPS at 20 MHz
Flash memory	32 kB
SRAM	2 kB
EEPROM	1 kB
Pin count	28-pin PDIP, MLF,32-pin TQFP, MLF
Maximum operating frequency	20 MHz
Number of touch channel	16
Hardware Q Touch Acquisition	No
Maximum I/O pins	23
External interrupts	2
USB Interface	No
USB Speed	-

4.3.3. ATMEGA 328P pin diagram

Atmega328P is a 28 pin microcontroller. It has 14 digital I/O pins, of which 6 can be used as PWM outputs and 6 analog input pins. These I/O pins account for 20 of the pins. The pin configuration is shown in Fig. 7.

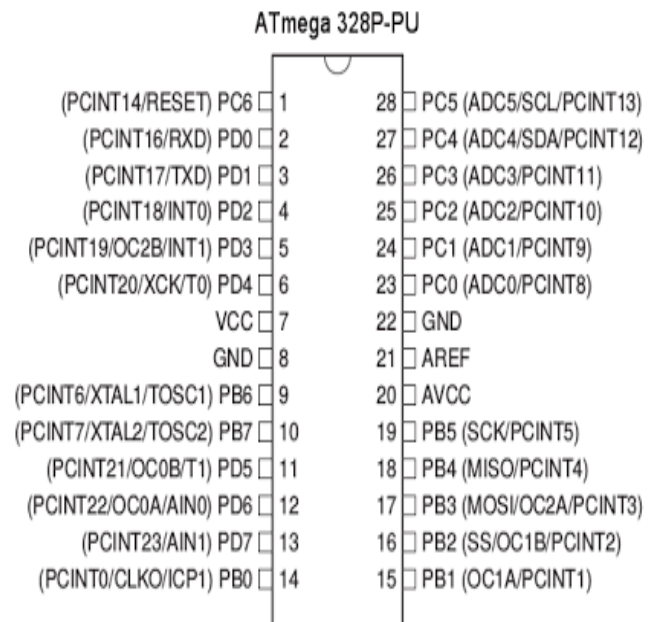

Fig -7: Pin configuration of atmega328P-PU microcontroller

5. WORKING PRINCIPLE

The obstacle avoidance robotic vehicle uses ultrasonic sensors for its movements. A microcontroller of 8051 family is used to achieve the desired operation. The motors are connected through motor driver IC microcontroller.

The ultrasonic sensor is attached in front of the robot. Whenever the robot is going on the desired path the ultrasonic sensor transmits the ultrasonic waves continuously from its sensor head. Whenever an obstacle comes ahead of it the ultrasonic waves are reflected back from an object and that information is passed to the microcontroller. The microcontroller controls the motors left, right, back, front based on ultrasonic signals. In order to control the speed of each motor pulse width modulation is used (PWM).

6. APPLICATION

- Obstacle avoiding robots can be used in almost all mobile robot navigation systems.
- They can be used for household work like automatic vacuum cleaning.

- They can also be used in dangerous environments, where human penetration could be fatal.

7. CONCLUSION

The above Arduino controller and ultrasonic sensor were studied and the HcSR-04 ultrasonic sensor was selected, as the controlling result are satisfying for its use in the automobile prototype system bring developed. It was used to sense the obstacle and avoidance them. On successful implementation of obstacle avoidance algorithm was successfully carried out too with minimal errors, by coding the algorithm in python. Obstacle avoidance is a very good application to be used in vehicle preventing many accidents and loss of life.

ACKNOWLEDGMENT

We would like to thank all those who have directly or indirectly encouraged us to take up this project.

REFERENCES

- [1] Chatelais Q., Vultur H, and Kanellis E., "Maze Solving by an Autonomous Robot", Aalborg University, 2014.
- [2] International Journal of Computer Applications, 2012, vol. 56, no. 5, pp. 8-13.
- [3] Mishra S., and Bande P., "Maze Solving Algorithms for Micro Mouse", IEEE International Conference on Signal Image
- [4] Dang H., Song J., and Guo Q., "An Efficient Algorithm for Robot Maze-Solving", in Proceedings of the 2010 Second
- [5] Gims M., "MICROMOUSE: Microprocessor Controlled Vehicle," University of East London, London, 1999.
- [6] <https://create.arduino.cc/projecthub/albertoz/obstacle-avoiding-robot-fb30e4>
- [7] <https://en.wikipedia.org/wiki/Robotics>