

DEVELOPMENT OF PICK AND PLACE ROBOT FOR INDUSTRIAL APPLICATIONS

Vishakha Borkar¹, Prof G.K.Andurkar²

¹P.G Student, Department of Electronics and Telecommunication Engineering, GCOE, Jalgoan

²Associate Professor, Department of Electronics and Telecommunication Engineering, GCOE, Jalgoan

Abstract - The pick and place robot is designed so that user is going to fill the liquid in bottle according to volume occupied in the bottle and after the bottle is filled robot will do pick and place operation by mechanical devices such as gripper and robotic arm. The design is carried out on a low-cost robot platform for development of pick and place the things. There is establishment of both wireless communication between the mobile robot and the remote base station, and serial communication between the remote base station and the GUI application. The base station requires the serial communication with the GUI application and also needs to be hardwired with the radio packet controller. Our aim is to be able to command and control the Robot wirelessly by the GUI application. The main task of this project is divided two parts: (1) to program the AVR microcontroller on both the base station and the robot interfaced to the radio packet controller module which would enable us to wirelessly control the robot; (2) to program the GUI application which would enable us to serially control the base station. Theoretical system limitation for the packet transmission is evaluated and analyzed. The packet stress to the wireless module while varying the number of robots and the payload data is tested. The wireless parts were evaluated with CRC error checking. It was observed that control through both wireless communication between the mobile robot and the remote base station, and serial communication between the remote base station and the GUI application. Hence the wireless communication and the serial communication were successful in the demodulation scheme.

1. INTRODUCTION

1.1 INTRODUCTION TO ROBOTICS

Robotics researchers regularly endow robot platforms with new capabilities that increase the breadth of potential applications and push the boundaries of autonomy. In contrast, industrial automation is driven by a pragmatism dictated by the need to optimize throughput and reliability. The hope of both is that, as multi-purpose robotic platforms become more capable, they will be able to take over an increasing fraction of the tasks currently handled by application specific, fixed installation automation, thereby granting all applications greater levels of modularity and adapt ability which is expressed in [1]. We are now seeing an acceleration of the rate at

which research robotics feeds into engineering practice. In this project we are trying to establish both wireless communication between the mobile robot and the remote base station, and serial communication between the remote base station and the GUI application. The base station requires the serial communication with the GUI application and also needs to be hardwired with the radio packet controller. Our aim is to be able to command and control the Robot wirelessly by the GUI Application as given in [3]. The main task of this project is two parts:

- (1) To program the AVR microcontroller on both the base station and the robot interfaced to the radio packet controller module which would enable us to wirelessly control the robot
- (2) To program the GUI application which would enable us to serially control the base station?

Theoretical system limitation for the packet transmission is evaluated and analyzed. We tested packet stress to the wireless module while varying the number of Robots and the payload data. The wireless parts were evaluated with CRC error checking. As a result, we achieved control both wireless communication between the mobile robot and the remote base station, and serial communication between the remote base station and the GUI application. This level of completely was successfully tested on groups at up to four robots. Hence the wireless communication and the serial communication were successful in the demodulation scheme.

A robot may appear like a human being or an animal or a simple electro-mechanical device. A robot may act under the direct control of a human (e.g., the robotic arm of the space shuttle) or autonomously under the control of a programmed computer. Robots may be used to perform tasks that are too dangerous or difficult for humans to implement directly (e.g., nuclear waste cleanup) or may be used to automate repetitive tasks that can be performed more cheaply by a robot than by the employment of a human (e.g., automobile production) or may be used to automate mindless repetitive tasks that should be performed with more precision by a robot than by a human (material handling, material transfer applications, machine loading and unloading, processing operations, assembly and inspection). The last two decades have witnessed a significant advance in the field of robots

application. Many more applications are expected to appear in space exploration, battlefield and in various actives of daily life in the coming years.

A robot is a mechanical device that performs automated tasks and movements, according to either pre-defined program or a set of general guidelines and direct human supervision. These tasks either replace or enhance human work, such as in manufacturing, contraction or manipulation of heavy or hazardous material. Robot is an integral part in automating the flexible manufacturing system that one greatly in demand these days. Robots are now more than a machine, as robots have become the solution of the future as cost labor wages and customers demand. Even though the cost of acquiring robotic system is quite expensive but as today's rapid development and a very high demand in quality with ISO standards, human are no longer capable of such demands. Research and development of future robots is moving at a very rapid pace due to the constantly improving and upgrading of the quality standards of products. In this project we are going to perform three main actions the robot is going to pick operation to place operation and to filled the quantity of liquid according to user.

1.2 KEY COMPONENTS OF ROBOT

Automation as a technology is concerned with the use of mechanical, electrical, electronic and computer-based control systems to replace human beings with machines, not only for physical work but also for the development of information processing. Industrial automation, which started in the eighteenth century as fixed automation has transformed into flexible and programmable automation in the last 15 or 20 years. Computer numerically controlled machine tools, transfer and assembly lines are some examples in this category.

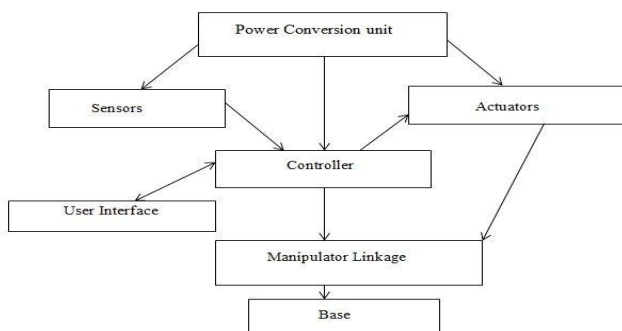

Figure1.1 Component of Robot

Common people are easily influenced by science fiction and thus imagine a robot a humanoid that can walk, see, hear, speak, and do the desired work as shown in figure 1.1. But the scientific interpretation of science fiction scenario propounds a robot as an automatic machine that

is able to interact with and modify the environment in which it operates. Therefore, it is essential to define what constitutes a robot. Different definitions from diverse sources are available for a robot.

1.3 LAW OF ROBOTICS

Isaac Asimov conceived the robots as humanoids, devoid of feelings, and used them in a number of stories. His robots were well-designed, fail-safe machines, whose brains were programmed by human beings. Anticipating the dangers and havoc such a device could cause, he postulated rules for their ethical conduct. Robots were required to perform according to three principles known as "Three laws of Robotics" which are as valid for real robots as they were for Asimov's robots and they are:

1. A robot should not injure a human being or, through inaction, allow a human to be harmed.
2. A robot must obey orders given by humans except when that conflicts with the First Law.
3. A robot must protect its own existence unless that conflicts with the First or Second law.

These are very general laws and apply even to other machines and appliances. They are always taken care of in any robot design.

1.4 ORGANIZATION OF REPORT

This topic is mainly focus on bottle filling, pick and place operation. It includes information as follows. Chapter 2 includes pick and place robot literature survey and history. It also contains comparison between various robot and feature of developed pick and place robot. Chapter 3 contains detail information about pick and place robot with bottle filling mechanism. Chapter 4 includes the comparison among existing and developed robot system and testing detailed for pick and place robot. Chapter 5 contains the conclusion and the future scope related to dissertation work.

2. DEVELOPMENT OF PICK AND PLACE ROBOT IN INDUSTRIAL APPLICATIONS

2.1 BLOCK DIAGRAM OF THE DEVELOPMENT OF PICK AND PLACE ROBOT

From the below proposed diagram for development of pick and place shown in figure3.1, User will give the input through GUI and it on soloniodal pump it will filled liquid in the bottle. The gripper is connected to robotic arm that pick the bottle according to programming of Microcontroller and place to desired location. Once work will completed it will report through RF module that work completed ready to do another work user can move the robot position and command through PC.

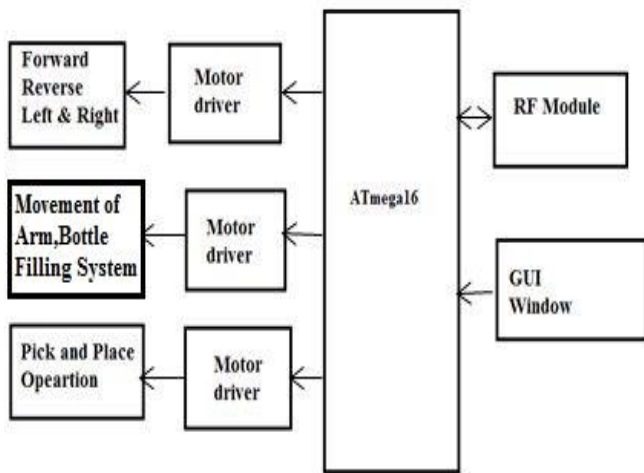

Figures 2.1 Block diagram for development of pick and place robot.

- Input and output devices: RF module.
- Input device: GUI window.
- Mechanical devices: Gripper, Robotic arm, solenoidal pump.

2.2 CIRCUIT DESIGN FOR DEVELOPMENT OF PICK AND PLACE ROBOT

The microcontroller operate the task such as forward ,reverse,left,right.It also performed bottle filling and pick and place operation. User sends the signal through RF module. Receiver circuit is interfaced to microcontroller to received it and execute the instruction according to the programming. It is high performance, low power AVR 8 bit microcontroller. The microcontroller is Atmega-16 that comes under AVR family which itself has an Analog to Digital Converter (ADC) converts the analog voltages of the sensors into digital form.

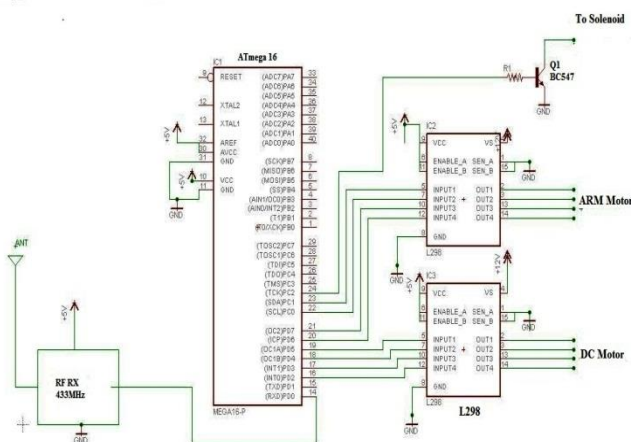

Figure 2.2 Circuit diagram of development of pick and place robot in industrial objective.

The microcontroller then sends data to the RF module using Rx-Tx (Receiver-Transmitter) Serial UART interface. The RF module manufactured by Roving Networks is used here is Atmega-16 that comes under AVR family which itself has an Analog to Digital Converter (ADC). The microcontroller then sends data to the RF module using Rx-TX (Receiver-Transmitter) Serial UART interface. The RF module manufactured by Roving Networks is used. Atmega16 has higher code memory and RAM as compare to 8051. The AVR is much faster. It executes most instructions in a single clock cycle, as against 12 for a standard 8051 or 6 for one of the high speed variants. If you're converting an existing project, it's really important to take this into account, or all the timing will be wrong. Further, AVRs have an internal calibrated clock option, so in many cases you don't need a crystal and gain two extra port pins. They had inbuilt circuitry for ADC , SPI , I2C, UART, internal pull up registers etc. with their L&H 8bit registers , they were capable of performing primitive 16bit operations by breaking down the data in to H and L 8 bit values. They even had internal oscillators on certain flavors

2.3 MATHEMATICAL MODELING FOR DEVELOPMENT OF PICK AND PLACE ROBOT

A system is an integrated whole of parts or subsystems. A system has specified goal or output for a given set of inputs; a system may have many goals as well. A robot is a system as it combines much subsystem that interacts among themselves as well as environment in which robot works.

2.3.1 Mathematical Model for DC Motor

DC motor of relatively small size, the relationships that govern the behavior of the motor in various circumstances can be derived from physical laws and characteristics of the motors themselves. Kirchhoff's voltage rule states, "The sum of the potential increases in a circuit loop must equal the sum of the potential decreases." When applied to a DC motor connected in series with a DC power source, Kirchhoff's voltage rule can be expressed as "The nominal supply voltage from the power source must be equal in magnitude to the sum of the voltage drop across the resistance of the armature windings and the back EMF generated by the motor.":

$$V_0 = (I \times R) + V_e$$

Where:

V_0 = Power supply (Volts)

I = Current (A)

R = Terminal Resistance (Ohms)

V_e = Back EMF (Volts)

The back EMF generated by the motor is directly proportional to the angular velocity of the motor. The

proportionality constant is the back EMF constant of the motor [5].

$$V_e = \omega \times k_e$$

Where: ω = angular velocity of the motor

k_e = back EMF constant of the motor

Therefore, by substitution:

$$V_o = (I \times R) + (\omega \times k_e)$$

The back EMF constant of the motor is usually specified by the motor manufacturer in volts/RPM or mV/RPM. In order to arrive at a meaningful value for the back EMF, it is necessary to specify the motor velocity in units compatible with the specified back EMF constant. The motor constant is a function of the coil design and the strength and direction of the flux lines in the air gap. Although it can be shown that the three motor constants normally specified (back EMF constant, torque constant, and velocity constant) are equal if the proper units are used, calculation is facilitated by the specification of three constants in the commonly accepted units. The torque produced by the rotor is directly proportional to the current in the armature windings. The proportionality constant is the torque constant of the motor.

$$M_o = I \times k_M$$

Where:

M_o = torque developed at rotor

k_M = motor torque constant

Substituting this relationship:

$$V = (M \times R) + (\omega \times k_M)$$

The torque developed at the rotor is equal to the friction torque of the motor plus the resisting torque due to external mechanical loading:

$$M_o = M_l + M_f$$

Where:

M_f = motor friction torque

M_l = load torque

Assuming that a constant voltage is applied to the motor terminals, the motor velocity will be directly proportional to sum of the friction torque and the load torque. The constant of proportionality is the slope of the torque-speed curve and can be calculated by:

$$\Delta n / \Delta M = n_0 / M_H$$

Where:

M_H = stall torque

n_0 = no-load speed

It is describing loss of velocity as a function of increased torsional load. So in this project requires DC motor for wheels (200 RPM), arm (100RPM) and gripper (60RPM).

2.3.2 Mathematical Model for ARM

From motor specifications we get, Torque = 2 kg-cm = 20 kg-mm and Radius of shaft of motor = 2.5 m.

Therefore, Torque = Force \times Radius of shaft

$$T = F \times R \dots \dots \dots (2.1)$$

Therefore force generated by motor can be calculated by equation (2.1)

$$\text{Therefore, } F = (20 / 2.5) \times g = 8 \text{ kg} \times g$$

$$M_B = m \cdot g \times 220 = 8 \times g \times \cos 20^\circ \times 145$$

$$\text{Therefore, } m = 4.95 \text{ kg}$$

Hence the maximum load calculated is 4.95 kg. The actual load will be less than the calculated value because the weight of the material used in constructing the arm was light and also weight of gripper mechanism was not taken into consideration.

2.3.3 Mathematical Model for Mechanical Gripper

A mechanical gripper is used as an end effector in a robot for grasping the objects with its mechanically operated fingers. In industries, two fingers are enough for holding purposes. More than three fingers can also be used based on the application. As most of the fingers are of replaceable type, it can be easily removed and replaced. A robot requires either hydraulic, electric, or pneumatic drive system to create the input power. The power produced is sent to the gripper for making the fingers react. It also allows the fingers to perform open and close actions [6]. Most importantly, a sufficient force must be given to hold the object. In a mechanical gripper, the holding of an object can be done by two different methods such as:

- Using the finger pads as like the shape of the work part.
- Using soft material finger pads.

In the first method, the contact surfaces of the fingers are designed according to the work part for achieving the estimated shape. It will help the fingers to hold the work part for some extent.

In the second method, the fingers must be capable of supplying sufficient force to hold the work part. To avoid scratches on the work part, soft type pads are fabricated on the fingers. As a result, the contact surface of the finger and μ - efficient of friction are improved. This method is very simple and as well as less expensive. It may cause slippage if the force applied against the work part is in the parallel direction. The slippage can be avoided by designing the gripper based on the force exerted.

$$\mu n f F_g = w \dots \dots \dots (2.2)$$

μ => μ - efficient of friction between the work part and fingers

$n f$ => no. of fingers contacting

F_g => Force of the gripper

w => weight of the grasped object

The equation (2.2) must be changed if the weight of a work part is more than the force applied to cause the slippage.

$$\mu n f F g = w g \dots\dots\dots (2.3)$$

g => g factor

During rapid grasping operation, the work part will get twice the weight. To get rid out of it, the modified equation (2.2) is put forward by Engel berger. The g factor in the equation (2.3) is used to calculate the acceleration and gravity.

2.4 SOFTWARE DESIGN

2.4.1 GUI Method for User Window Design Technique

A graphical user interface (GUI) is a graphical display that contains devices, or components, that enable a user to perform interactive tasks. To perform these tasks, the user of the GUI does not have to create a script or type commands at the command line. Often, the user does not have to know the details of the task at hand. The GUI components can be menus, toolbars, push buttons, radio buttons, list boxes, and sliders just to name a few. In MATLAB, a GUI can also display data in tabular form or as plots, and can group related components. The GUI contains

- An axes component
- A pop-up menu listing three data sets that correspond to MATLAB Functions: peaks, membrane, and sink
- A static text component to label the pop-up menu
- Three buttons that provide different kinds of plots: surface, mesh, and contour. When you click a push button, the axes component displays the selected data Set using the specified plot.

Each component, and the GUI itself, are associated with one or more user-written routines known as callbacks. The execution of each callback is triggered by a particular user action such as a button push, mouse click, selection of a menu item, or the cursor passing over a component [7]. The creator of the GUI, provide these callbacks. The callback functions you provide control how the GUI responds to events such as button clicks, slider movement, menu item selection, or the creation and deletion of components. There is a set of callbacks for each component and for the GUI figure itself. The callback routines usually appear in the M-file following the initialization code and the creation of the components. This kind of programming is often referred to as event-driven programming. The event in the example is a button click. In event-driven programming, callback execution is asynchronous, controlled by events external to the software. In the case of MATLAB GUIs, these events usually take the form of user interactions with the GUI. The writer of a callback has no control over the sequence of events that leads to its execution or, when the callback does

execute, what other callbacks might be running simultaneously [6].

2.4.1.1 Algorithm for designing the GUI window

1. First declare the character A to H. A= dc motor forward, B= dc motor reverse= left, D=right, E= solenoid of= solenoid off, G= relay on, H= relay off.
2. Create push pull button labeled the name and select the size.
3. Select the baud rate 9600. The baud rate is the rate at which information is transferred in a communication channel. In the serial port context, "9600 baud" means that the serial port is capable of transferring a maximum of 9600 bits per second. If the information unit is one baud (one bit), the bit rate and the baud rate are identical. If one baud is given as 10 bits, (for example, eight data bits plus two framing bits), the bit rate is still 9600 but the baud rate is 9600/10, or 960. You always configure Baud Rate as bits per second. Therefore, in the previous example, set Baud Rate to 9600.
4. Now generate the M File.
5. Through the RF module User will transmit the instruction to Robot. The designed window will show in figure 2.3 GUI window.

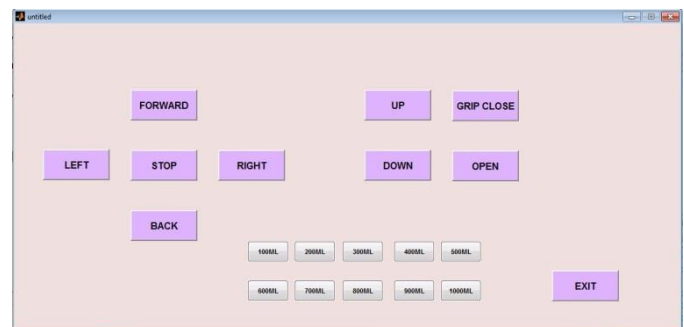

Figure 2.3 GUI Window

2.4.2 Micro AVR for Atmega16 Programming

Micro PRO for AVR® organizes applications into projects consisting of a single project file (file with the .cap extension) and one or more source files (files with the .c extension). The micro PRO for AVR® compiler allows you to manage several projects at a time. Source files can be compiled only if they are part of the project [8]. AVR is a family of microcontrollers developed by Atmel beginning in 1996. AVR was one of the first microcontroller families to use on-chip flash memory for program storage, as opposed to one-time programmable ROM, EPROM, or EEPROM used by other microcontrollers at the time. Re: aver microcontroller. According to Wikipedia, AVR stands for either 'Advanced Virtual RISC' or 'Alf and Vegard [RISC]': The AVR basic architecture was conceived by two students at the Norwegian Institute of Technology (NTH) Alf-Egil Bogen and Vegard Wollan.

A project file contains:

- Project name and optional description;
- Target device in use;
- Device clock;
- List of the project source files;
- Binary files (*.mcl); and
- Other files.

2.4.2.1 Algorithm for programming robot

1. As the character is declared in matlab it transmits character.
2. As the receiver module , it receives we designed the code for each instruction
- 3.It enables the pin of atmega16.
4. Assign delay of 300ms.
5. It follows the instruction given to robot.
6. Then come exit.

The below flowchart figure 2.4 gives description robot control programming. The system is operated at 12V and 2A.As the system started it will receive the signal from user that is from GUI programming through RF module. The characters are assigned in above algorithm. There are condition blocks for A, B, C, D, E, F, G and H.

- A = Forward
- B = Reverse
- C= Right
- D= Left
- E= Arm up
- F= Arm down
- G= Relay on
- H= Relay off

The A is assigned to robot moves forward if user gives character A then robot moves in forward direction otherwise it follows next iteration

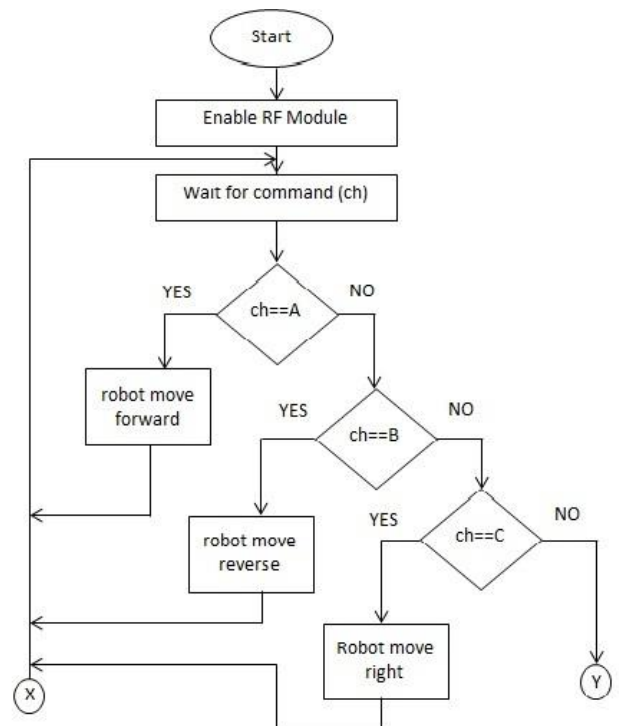

Figure 2.4(a) Flowchart for robot control programming system.

When the condition $ch==B$ is executed the character B is assigned to robot move reverse, otherwise it goes toward next loop. In that loop if $ch==C$ is given then robot moves right side. The no action is denoted by X. From the figure 2.4 b, Y is conditional block, if the character $ch==E$ is received, the robot arm up for picking the bottle. When $ch==F$ is received then arm of robot down for placing the bottle.

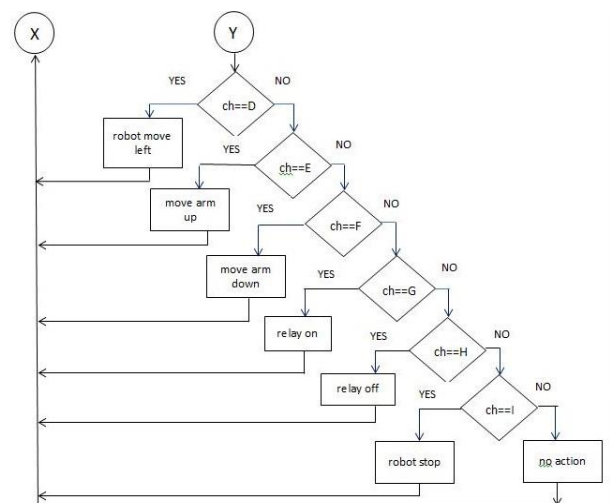

Figure 2.4(b) Flowchart for robot control programming system.

The user give the input quantity to fill the liquid, for the program ch==G is received. The relay is on for certain amount of time. For relay stop action as desired time is completed, it receives the ch==When ch==I is received if yes then robot stop otherwise no action.

3. PERFORMANCE METHODOLOGY

3.1 COMMENTS ON DEVELOPMENT OF PICK AND PLACE ROBOT

Robots are outfitted with wide reaches and slim arms, steady repeatability and precise tooling - all of which allows them to be extremely accurate. This high precision capability makes them a good match for applications. One of the main advantages of is flexibility. robots are easily programmable. They are able to accommodate multiple changes in product shape and type. In addition, robots provide a high level of movement flexibility. Robot systems have the ability to improve product quality and cycle time. Robotic movements are regulated, so the results are always the same. Quality is improved because of this regularity. Furthermore, this consistency allows the processes to take place. Because they are designed with compact base s, pick and place robots are ideal if you are looking to conserve floor space. Robots can be programmed to move within strict limits - leading to even better use of space. Pick and place applications can be physically demanding [9]. They are labor-intensive, repetitive, and monotonous. Depending on the weight and size of a part, moving it from one place to another can be very demanding work. Pick and place robots are unaffected by the stresses of the application. They are able to work without taking breaks or making mistake. Incorporating pick and place robots can effectively cut your costs. Robotic precision and reliability allow for less wasted material and more efficient use of time. Plus, the initial investment in robots is quickly recouped - making pick and place robots an extremely cost-effective solution.

In industrial point of view, it has very few problems in overcoming to developed system. The initial investment to integrate automated into your business is significant, especially when business owners are limiting their purchases to robotic equipment. The cost of should be calculated in light of a business' greater financial budget. Regular maintenance needs can have a financial toll as well. Without planning, companies can have difficulty achieving their goals. Employees will require training program and interact with the robotic equipment. This normally takes time and financial output. Robots may protect workers from some hazards, but in the meantime, their very presence can create other safety problems. These dangers must be taken into consideration.

3.2 CALCULATION FOR DC MOTOR

Motor is to be operated with 12 volts applied to the motor terminals. The torque load is 0.00141 N-m. Find the resulting motor speed, motor current and efficiency. From the motor data sheet, it can be seen that the no-load speed of the motor at 12 volts is 200 rpm. If the torque load is not coupled to the motor shaft, the motor would run at this speed. The motor speed under load is simply the no-load speed less the reduction in speed due to the load [10]. The proportionality constant for the relationship between motor speed and motor torque is the slope of the torque vs.speed curve, given by the motor no-load speed divided by the stall torque. In this example, the speed reduction caused by the 0.00141 N-m torque load is: $0.00141 \text{ N-m} \times (200 \text{ rpm} / .0044770 \text{ N-m}) = -200 \text{ rpm}$
The motor speed under load must then be:
 $11,700 \text{ rpm} - 3690 \text{ rpm} = 8010 \text{ rpm}$

The motor current under load is the sum of the no-load current and the current resulting from the load. The proportionality constant relating current to torque load is the torque constant (k M), in this case, 0.007336 oz -in/A. In this case, the load torque is 0.00141 N-m, and the current resulting from the load must be:
 $I = 0.00141 \text{ N-m} \times 1 \text{ amp} / 0.007336 \text{ N-m} = 192 \text{ mA}$

The total motor current must be the sum of this value and the motor no-load current. The data sheet lists the motor no-load current as 11 mA. Therefore, the total current is:
 $192 \text{ mA} + 11 \text{ mA} = 203 \text{ mA}$

The mechanical power output of the motor is simply the product of the motor speed and the torque load with a correction factor for units (if required). Therefore, the mechanical power output of the motor in this application is:
 $\text{Output power} = 0.2 \text{ N-m} \times 8010 \text{ rpm} \times .00074 = 1.18 \text{ Watts}$

The mechanical power input to the motor is the product of the applied voltage and the total motor current in Amps. In this application:
 $\text{Input power} = 9 \text{ volts} \times .203 \text{ A} = 1.82 \text{ Watts}$

Since efficiency is simply power out divided by power in, the efficiency in this application is:
 $\text{Efficiency} = 1.18 \text{ Watts} / 1.82 \text{ Watts} = .65 = 65\%$

3.3 RESULT OF DEVELOPMENT OF PICK AND PLACE ROBOT

Testing can be automated to free workers from repetitive tasks, as well as to increase test consistency and traceability. If the data coming from the robot into quality assurance system then detection of abnormalities during your production process can be done.

- ON Time characteristics calculated by making robot working up to maximum time. It checked how much time system will work by taking output we get 4 hr for development of pick and place robot.
- For accuracy it is PC operated so accuracy it will depend on User. Robot ability to position as the end point in space upon receiving a control command without previously having attained that position.
- Range of operation depend range of RF module. In this project RF module range is 30m.
- In 1 hr checking of how many bottle filled liquid is done. For this system development of pick and place robot filled 50 for beginner and 80-100 for expert level.
- Load carriage capacity it will depend on wheel's diameter.
- Robot equipment maintenance helps to reduce the breakdown of robots through preventive maintenance. This system required low level of maintenance.

3.4 STASTICAL ANALYSIS OF DEVELPED OF PICK AND PLACE ROBOT

The number of test taken verse distance as parameter and other graph taken number of test taken verse Actual bottle filled (ml) desired of (200ml).From reading taken accuracy and precision can be concluded.

Table 3.1 Data analyses by taking the parameter as distance.

Number of test taken while doing pick and place operation	Actual distance travelled desired of (3m)
1	2.9
2	3
3	2.8
4	3
5	2.9
6	3
7	2.8
8	2.7
9	3.1
10	3
11	3.2
12	2.8
13	2.9
14	3
15	3

From the above table no 3.1, 15 test are taken during pick and place operation.the desired distance is 3m in the desired time (t=30sec).The result is got during pick and place operation. The median i, e maximum time we get 2.93517m through practical. The desired output is considered as 3m.

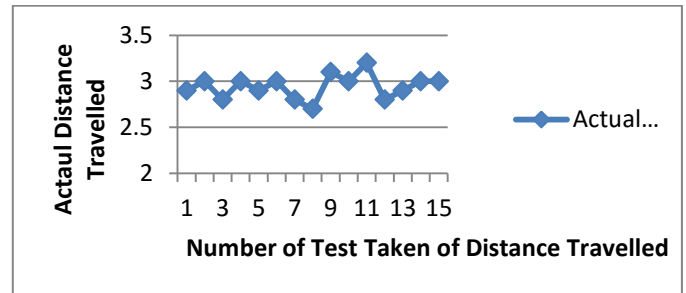

Figure 3.1 Actual distance travelled vs number of test taken of distance travelled.

From the above Figure 4.1, the average is resulted as 2.93517.It is concluded that the operations are performed get the nearly equal to desired result. The above 0.064 error are occurred due to non linarites, atmospheric effect.

Table 3.2 Data analyses by taking the parameter as quantity of liquid.

Number of test taken while doing pick and place operation	Actual bottle filled (ml) desired of (200ml)
1	200
2	199
3	200
4	201
5	200
6	200
7	200
8	198
9	199
10	200

From the above table 3.2 the readings are taken during performing the test. The robot kept on through the user gave the command of 200 ml with different time, the result is achieved. From the calculation of graph as shown in figure 3.2, the result i.e. Median means maximum time quantity of liquid is filled is 200 ml. The average result is of 199.6 means the system result is nearly equal to desirable quantity. The robot doesn't have accuracy but it has factor affecting or the factor through which estimation of accuracy is done. One of the major factors is precision.

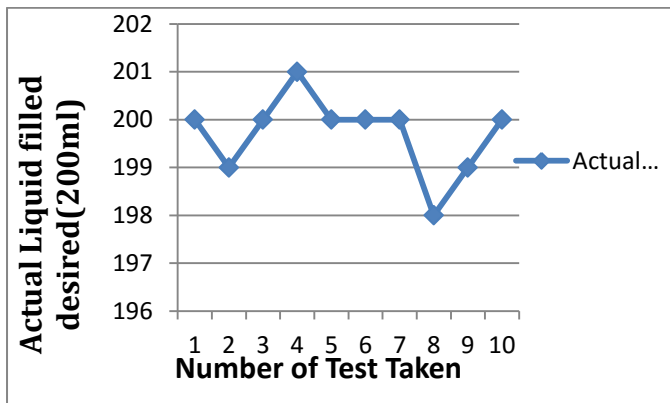

Figure 3.2 Actual bottle filled vs number of test taken of distance travelled.

It means that the result is obtained how much differed from each other as our desired quantity is of 200 ml. In the statistical definition precision is nothing but standard deviation the robot has 89.83. It is nearly equal to ideal robot capability

3.5 ROBOT FROM TOP AND BOTTOM VIEW

Pick and place robot in industrial application consist of base, arm, gripper, tank having capacity of 1 lit. This robot is moving vehicle which can lift, filled the bottle and place the bottle to the desired location. The arm of robot works with the help of pulley mechanism which is actuated by motor. The end effector used here is gripper.

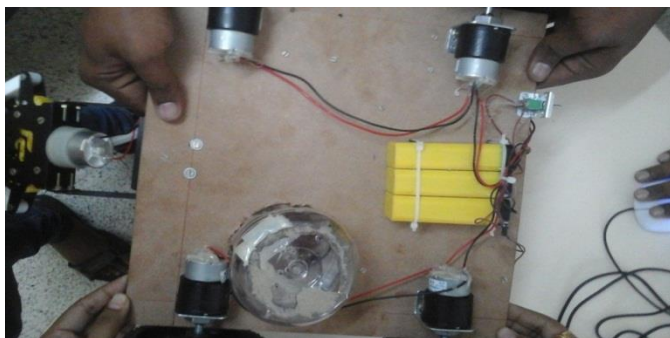

Figure 3.3 Photograph of robot from bottom view

User will give the input through GUI and it on solenoidal pump it will filled liquid in the bottle. The gripper is connected to robotic arm that pick the bottle according to programming of Microcontroller and place to desired location. Once work will completed it will report through RF module that work completed ready to do another work user can move the robot position and command through PC.

From figure 3.3 dc motor and battery of 12V @ 2A placed at bottom. The entire component placed on wooden chassis. The dc motors from each side are connected in

series and opposite side are connected in parallel. The switch is used to on and off the robot.

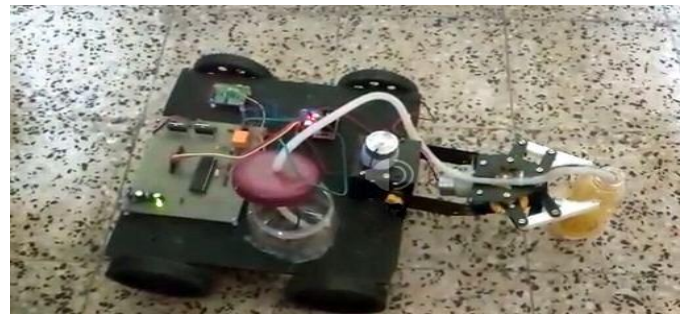

Figure 3.4 Photograph of Robot from top view

Figure 3.4 shows side view of robot. On the top of robot system the microcontroller circuit and motor controlled driver is assembled. The tank is fixed on it. The plastic pipe is used to fill the liquid in the bottle. The quantity is decided by user through GUI window. The system provides so many functions to the user. There are many key which operate motion of robot that is left, right, forward, stop and reverse. For pick the thing there is gripper on and gripper off buttons are provided at GUI window. For place the thing there are arm up and arm down. For filling the bottle there are direct quantity button are displayed on GUI window such as 100, 200 up to 2 lit. The relay is on for respective amount of time.

The system is user defined, who is driver here. If any case obstacle come user can easily handle the situation. In the field work system easily operated in rainy season precaution is taken that all circuits are placed at plastic box.

4 CONCLUSIONS

The design and development of pick and place robot has been carried out. A prototype was confirmed functional working of robot system. This system would make it easier for human beings to pick and place the risk of handling suspicious objects, which could be hazardous in its present environment and workplace. Complex and complicated duties can be achieved faster and more accurately with this design. A robotic arm is implemented using Atmega16 in pick and place objects more safely without incurring much damage. The robotic arm used here contains a soft catching gripper, which safely handles the object. In the modern era, time and man power are major constraints for the completion of a task. By the use of product, the industrial activities and hazardous operations can be done easily and safely in a short span of time. The use of soft catching gripper and low power wireless communication technique like RF module makes our system more effective when compared to other systems. The developed system is capable of lifting only small weights; by

introducing high torque motor large weights can be picked. A wireless camera can also be implemented to track the movement of the vehicle and thus it can be used for defence purposes. The range is also a limitation here but it can be enhanced.

In this project, it was observed that control through both wireless communication between the mobile robot and the remote base station, and serial communication between the remote base station and the GUI application. The main task of this project was to program the AVR microcontroller on both the base station and the robot interfaced to the radio packet controller module which would enable to wirelessly control the robot and to program the GUI application which would enable us to serially control the base station.

4.1 FUTURE SCOPE

Our efforts to develop a low-cost integrated system for development of pick and place robot have thus far resulted in the iterative development of a tested, proven hardware platform. The software stack has been developed for localization, navigation, and radioactive element detection. Future work can be done on the robustness of court localization and further code optimizations, which are two necessary steps for the integration of these components.

The eventual goal for this project is fully automated bottle filling pick and place robot with minimum space. The preliminary results for localization, motion planning and bottle detection are encouraging. The communication from the Robots to GUI application can be implemented through the base station so that it can control up to 10 Robots from the GUI application through the base station that use a secured wireless channel using encryption and decryption. Considerably larger bandwidth system should be on board because video streaming service is desired. The future work can make the system robust to environmental variations; it can also aim to develop the decision-making functionality of the platform to create a truly autonomous system.

REFERENCES

[1]RK Mittal and IJ Nagarath "Robotics and Control" BITS Pilani, 2003.

[2]Jong Hoon Ahnn, "The Robot control using the wireless communication and the serial communication." May 2007.

[3]Ratheesh Rajan "Foundation Studies for an Alternate Approach to Motion Planning of Dynamic Systems" M.S.E., the University of Texas at Austin, 2001.

[4]S.R.Deb "Robotics technology and flexible automation".

[5]Subrata Ghoshal "Embedded systems and robotics".

[6]A.S.C.S. Sastry, K.N.H. Srinivas (2010), "An automated microcontroller based the mixing system", International journal on computer science and engineering. (Volume II, Issue 8, August 2010).

[7] B.O.Omijeh, R.Uhunmwangho, M.Ehikhamenle, "Design analysis of a remote controlled pick and place robotic vehicle", International journal of Engineering Research and Development. (Volume 10, Issue 5, May 2014).

[8] MATLAB® 7 Creating Graphical User Interfaces.

[9] https://en.wikipedia.org/wiki/Robot_software.

[10] https://en.wikipedia.org/wiki/Robotic_process_automation.