

# Green Charge: Managing renewable energy using Piezo sensors

Smita R N<sup>1</sup>, Sharada P N<sup>2</sup>, Lubna Afza<sup>3</sup>, Anjaiah vasipalle<sup>4</sup>

<sup>1,2,3,4</sup> Assistant Professor, Department of Electronic and Communication, KNSIT, Bangalore

\*\*\*

**Abstract** - Human beings require different source of energy for day to day activity. It won't be wrong to say with different source of non-renewable energy used, life has been considerably easy for a whole species of mankind. Some of the notable non-renewable energy sources such as thermal energy by means of burning coal, use of petroleum energy for motor vehicle etc. has left these naturally occurring non-renewable energy exhausted as well as causing adverse effect to the environment. This is where the need of renewable energy arises. Moreover, renewable energy can be used to bridge the energy gap in a country like India. Piezo-electricity is one such source of renewable energy which when used efficiently can be used to power up different manmade structures. Piezoelectric materials devices have ability to couple mechanical and electrical properties because there are excellent power generating device i.e application of electric field to a piezo-electric sensors causes it to strain and when strain is applied on Piezo-electric Sensors electric field is generated. This paper deals with harnessing of the strained energy and uses the stored energy to power up devices. Document

**Key Words:** ARM7 Microcontroller, Piezo Sensor, LDR Sensor, Temperature sensor, PIEZO Sensor.

## 1. INTRODUCTION

### 1.1 Overview:

Energy is one of the most important global issues. There are basically two forms of energy source: -

- Renewable energy source.
- Non-renewable energy source.

To start off with the latter, Non-renewable energy is an efficient source of energy utilized by humans to simplify their day to day life. Imagine life without electricity or without motor vehicles, sure it doesn't sound easy, but if we consider the running of a motor vehicle with the burning of petroleum based oil, the consumption of these products has increased many folds leaving this natural resource exhausted. Similarly, one of the ways by which electricity is produced is by means of thermal power generation which requires the burning of coal, which has left this resource almost nothing but exhausted and at the same time causing adverse effect to the environment. So, it is the need of the hour to reduce the usage of this sort of energy source and move towards an environment friendly energy source.

Harvesting of renewable energy is a great way to overcome the difficulty mentioned above. Different forms of renewable energy that can be harvested are: -

- Solar energy harvesting.
- Wind energy harvesting.
- Pressure (Strain based) energy harvesting.

Here, we are concerned with pressure energy harvesting which is based upon the law of conservation of energy. Let us consider the movement of cars which exert a certain amount of force per unit area on the road, if this energy could be harvested and converted to electric energy and then use the energy to power up man-made structure, it would be a great way in reduction of usage of non-renewable energy as well as bridging the energy requirement of a country.

Piezoelectric material shows inverse phenomenon i.e., when pressure is applied on a piezoelectric material, it generates electric field and inversely when an electric field is applied on piezoelectric material it develops strain. Due to this property piezoelectric material can be used as a sensor. These sensors can be used effectively for the generation of electricity by application of pressure.

### 1.2 Problem statement:

This paper deals with harvesting of wasted (pressure) energy. Much of the world depends on the non-renewable energy which are scarce to begin with and it is well known fact the amount of trouble it has lead us into such as global warming, air pollution etc. So, it was of utmost importance that humans start looking for alternative energy source which is eco-friendly such as solar energy, wind energy, pressure energy. In this project, we deal with the usage of pressure energy and generate electricity by means of piezoelectric sensor which can be used to power up lights and would ensure use of clean energy.

### 1.3 Proposed system:

The system proposed is a module which uses Piezo sensors to generate electricity and the generated electricity is used in the project for various applications. Basically, the module focuses on pressure energy harvesting, which under normal circumstances is wasted.

## 2. SYSTEM OVERVIEW

This shows the basic block diagram. It is divided into three main blocks:

1. Generation of power from the piezoelectric material. This is the starting point of our project; here the power is generated by applying the pressure on piezoelectric sensors present in mat.
2. Rectification of generated AC voltage. As the power generated from the piezo material is AC is needed to be rectified.
3. Storage of rectified voltage.
4. Indicates power level and status of the battery.

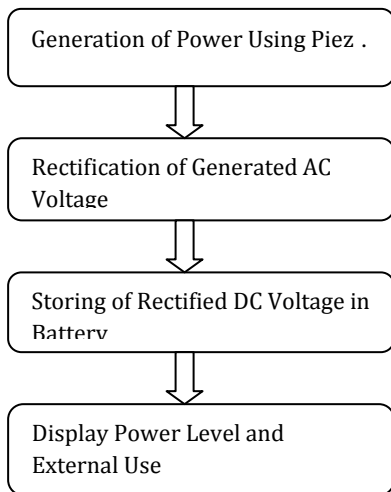

Fig1: Basic block diagram

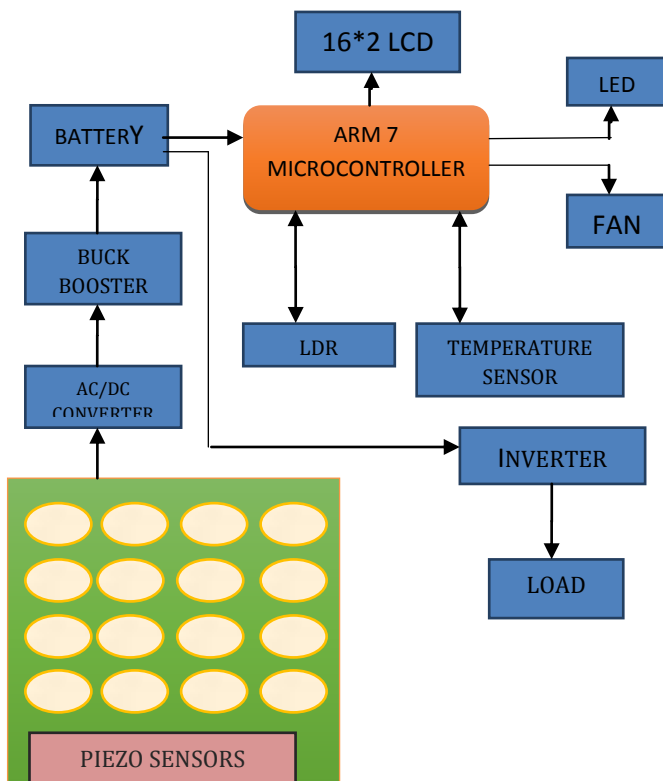

Fig 2: Main block diagram

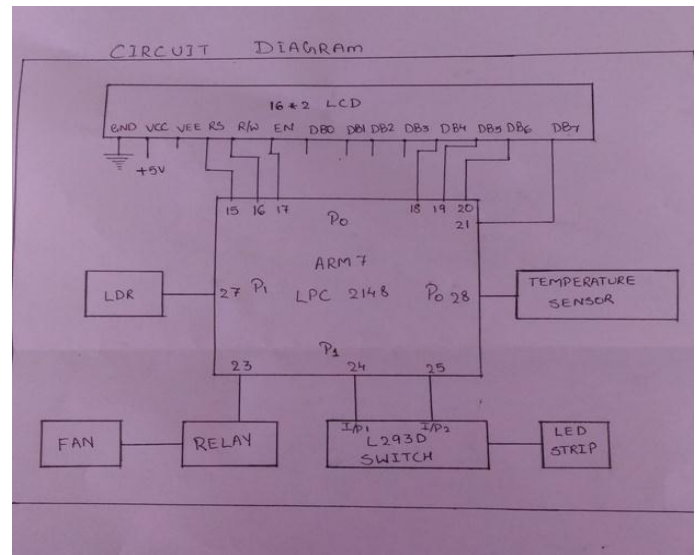

Fig 3: Circuit Diagram

The block diagram represents the module of the project. The piezo sensors are connected in both series and parallel to produce an amplified output in the form of voltage and current. Whenever some pressure is applied on the board containing the piezo-sensors a small amount of voltage and current is generated. Both the sets of parallel and series connections are forwarded to the bridge rectifier which converts the variable voltage into a linear one. The AC/DC converter used also has some storage capacity so that it can transfer the required 3V to the buck booster which can then transform the 3V DC to 21V DC. The buck booster is used to boost the small energy generated from the piezo sensors and provide the boosted energy to run the components used in the module. Storing the charge coming from the buck booster is done by using a lead-acid battery which stores the electrical energy by converting it to chemical energy and discharges by doing the vice versa. The microcontroller is run by the power provided by the battery. The microcontroller uses the lcd to display the charge generated from the piezo-sensors and the room temperature using the lm35 temperature sensor. The microcontroller monitors the ldr sensor, when a '1' is transmitted from the ldr sensor the microcontroller assumes it a day and does not turn on the light. When a '0' is transmitted from the ldr sensor, the microcontroller is programmed to turn on the light as the ldr sensors transmits a '0' when it is dark. The temperature from the LM35 temperature sensor is also monitored by the microcontroller which turns on the fan whenever the temperature exceeds 38degree Celsius.

### 3. HARDWARE AND SOFTWARE REQUIREMENT

#### 3.1 Hardware requirements:

- Microcontroller: - The microcontroller used is ARM7 LPC2148. Microcontroller here is basically used to operate the loads which work upon the instruction provided by the different sensors.

- Piezo-sensors: - Piezo sensors generate electricity upon the application of pressure. This electric energy is used in the project.
- LDR sensor: - This sensors determine whether it is day or night based upon that the light is turned on.
- Temperature sensor: - This sensor is used to indicate the temperature based on the temperature indicated, the microcontroller decides whether to turn on the fan or not
- Lead acid Battery: - The battery is used to store the electric energy generated by the Piezo-sensors.
- Buck-Booster: - Buck-Booster is used to amplify the voltage generated by Piezo sensors.
- LCD display: - LCD display is used to indicate the status of different devices connected to the microcontroller
- Fan: - A DC motor fan is used to run whenever the temperature gets too high as indicated by temperature sensor.
- Load: - A bulb is used as a load and whenever the LDR sensor indicates night, it glows.

#### 4. RESULTS

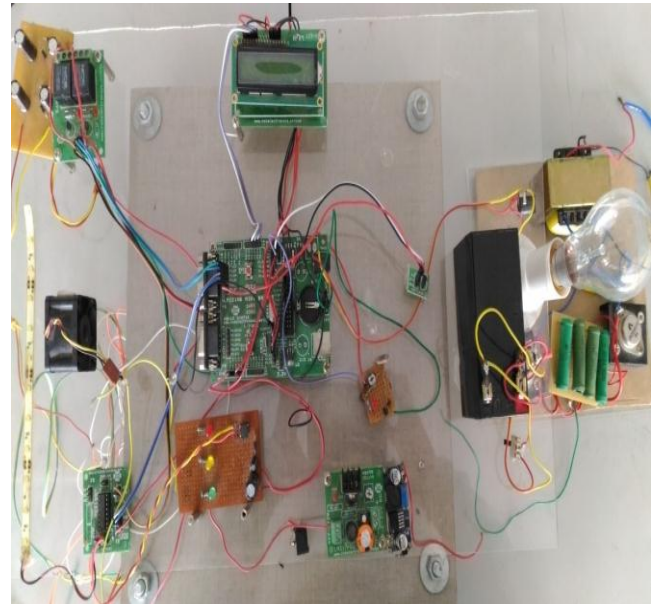

Fig 5: Circuit Diagram

#### 3.2 Software requirement:

- Embedded C( keil vision): - This language is used to program the microcontroller
- Flash magic: - Flash magic is used to dump the hex code generated by execution of the program on to the microcontroller.

#### 3.3 Flowchart:

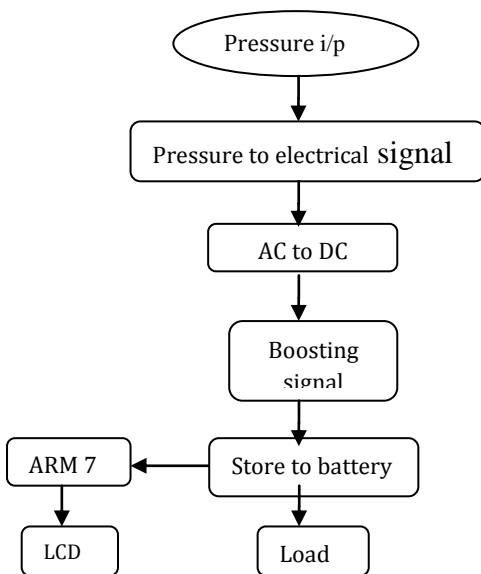
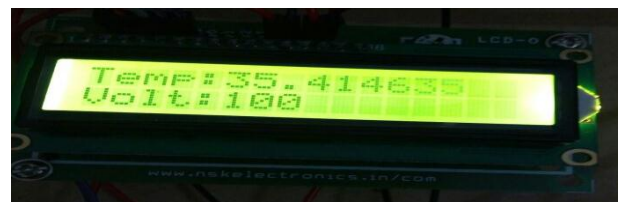

Fig 4: Flowchart based on working module



Step1: When the microcontroller is turned ON “WELCOME TO GREEN CHARGE” is displayed.



Step2: It then displays the surrounding temperature and the voltage stored in the Capacitor.



Step 3: When light does not fall on the LDR Sensor, LED Strip is turned on and “DARKNESS LIGHT IS ON” is displayed on the LCD.

