

Taguchi method of optimization performed on 49 cm² active area on interdigitated flow channel of PEMFC

Dr V LAKSHMINARAYANAN

Department of Mechanical Engineering, B V Raju Institute of Technology, Narsapur, Telangana, India - 502313

Abstract - In this paper, optimization of operating and design parameters on interdigitated flow channel with 49 cm² effective area of the Proton Exchange Membrane Fuel Cell (PEMFC) was considered numerically using CFD and Minitab 17 software. The factors considered for the optimization was landing to channel width ratios (L: C) -1:1, 1:2, 2:1 and 2:2, operating pressure (1, 1.5, 2 and 2.5 bar), temperature (313, 323, 333 and 343 K), anode and cathode reactants as stoichiometric ratios (S/F) of 3, 3.5, 4 and 4.5. Based on the optimization study, the L:C-1:2 has maximum influence on PEMFC performance and square of response factor (R²) was achieved by Taguchi method as 99.9 %.

Key Words: Interdigitated flow channel; CFD; Optimization; Design parameters; operating parameters.

1. INTRODUCTION

The Proton Exchange Membrane Fuel Cell (PEMFC) is an electrochemical device, which is converting chemical energy of fuels (hydrogen and oxygen) directly into electricity without any intermediate stage like classical combustion of two and four stroke engine. The PEMFC performance depends on the channel depth and width, flow channel design, number of flow path, cross section of the flow channel, operating pressure, temperature, relative humidity, mass flow rate of the reactant gases and stoichiometric ratio of the reactants. It is being developed for commercial applications in the field of transportation and back-up power. One of the main advantages of the fuel cells is the negligible emission of pollutants, such as SO_x, NO_x, particulates. It is Eco-friendly power source which is suitable for powering both portable devices and mobile application due to their high energy density and lower operating temperature range [1 & 2]. The effect of the various parameters like landing width to channel width of (L: C) 1:1, 1:2 and 2:2 Multi pass serpentine flow channel PEMFC with 36 cm² (6cm x 6cm) active area was analyzed numerically by Lakshminarayanan et al [3]. The results revealed that the maximum power densities were obtained 0.658W/cm² for the L: C of 1:1. Guvelioglu & Stenger [4] studied a CFD model to analyse the effects of channel size, electrode porosity and reactant humidification on the performance of PEMFC. The results revealed that smaller sized channels were required to obtain the higher current densities, although larger channels were satisfactory to produce moderate current densities. The effect of the relative humidity of the anode gas stream

was found to be the important factor for affecting the performance of the PEMFC.

Ahmed & Sung [5] investigated the performance of PEMFCs with different flow fields like a rectangular, trapezoidal and parallelogram using CFD. The results showed that a rectangular flow field gave higher cell voltages compared with parallelogram and trapezoidal flow fields. However, the trapezoidal flow field helped reactant diffusion, uniform reactant flow and current density circulations over the reacting area, results in lower cathode over potential of the fuel cell. The performance enhancement of the combined effect of design and operating parameters of both serpentine and interdigitated flow channel with 25 cm² active area of PEM fuel cell with four different parameters using optimization technique and CFD carried out by Lakshminarayanan and Karthikeyan [6]. The results revealed that the peak power density of interdigitated flow channel with landing to channel width (L:C)1:2 showed better than the serpentine flow channel with L:C-1:2. Grujicic and Chittajallu [7] have studied the performance of PEMFC by using a single-phase two-dimensional electrochemical model. The model was coupled with a nonlinear constrained optimization algorithm to define an optimum design of the fuel cell with respect to the operation and the geometrical parameters of the cathode. The results of the optimization analysis showed that higher current densities at a constant cell voltage were obtained as the inlet air pressure. On the other hand, the statistical sensitivity analysis results showed that the equilibrium cathode/membrane potential difference has the largest effect on the predicted polarization curve of the PEMFC. Karthikeyan et al. [8] studied the performance of single channel PEMFC using Taguchi method for various operating and design parameters like cell temperature, back pressure, anode and cathode inlet velocities, porosity and thickness of the gas diffusion layer, cathode water mass fraction, flow channel dimensions, rib width and porous electrode thickness. The results revealed that the back pressure showed maximum effect and rib width had less effect on the PEMFC performance in the first stage. Further, enhancement of power density by 3% when selected factors in the second stage of fine-tuned optimization has been carried out.

Wu et al. [9] integrated the neural network and Taguchi technique for parametric analysis with various parameters like operating temperatures, cathode and anode humidification temperature, operating pressure, and reactant flow rate for the enhancement of PEMFC

performance. The results indicated that among the various parameters, temperature and pressure were the major factors to influence the PEMFC performance. The effects of interdigitated flow channel with traditional flow channel, the effects of the flow area ratio and the baffle-blocked position of the interdigitated flow field on the performance of PEMFC were examined experimentally by Yan et al [10]. The results concluded that, the cell performance can be enhanced with an increased inlet flow rate of reactant and cathode humidification temperature. The interdigitated flow fields have better performance than conventional flow field design. Also the results showed that the interdigitated flow field has larger limiting current density, and the power output was about 1.4 times than the conventional flow field. It is clearly indicated that immediate attention is required for optimizing the simultaneous influence of operating and design parameters for the performance of the PEMFC. Hence this paper has a detailed study about the optimization of operating parameters like operating pressure, temperature, stoichiometric ratio of inlet reactant mass flow rate and design parameter like various rib width to channel width (L:C)-1:1, 1:2, 2:1 & 2:2 on interdigitated flow channel of 49 cm² active area of PEMFC are to be studied and compared the influence of individual parameters contribution on the total performance of PEMFC.

2. MODEL DEVELOPMENT

The modeling was done by creating all individual parts of the PEMFC and the dimensions of individual parts such as the anode and cathode GDL, solid polymer electrolyte membrane, the anode and cathode catalyst layers as shown in the Table 1. Three dimensional (3-D) PEMFC model with interdigitated flow channel of various landing width to channel width ratio (L: C) -1:1, 1:2, 2:1 and 2:2 was created by Creo Parametric 2.0 and meshed by using ICEM 14.5 (a module of Ansys 14.5) as shown in Fig.1.

Table -1: Dimensions and Zone type of parts assigning of fuel cell

S. No	Part Name	Width (mm)	Length (mm)	Thickness (mm)	Zone type
1	Anode & Cathode Flow channel	70	70	10	Solid
2	Anode & Cathode catalyst			0.08	Fluid
3	Membrane			0.127	Fluid
4	GDL anode & cathode			0.3	Fluid

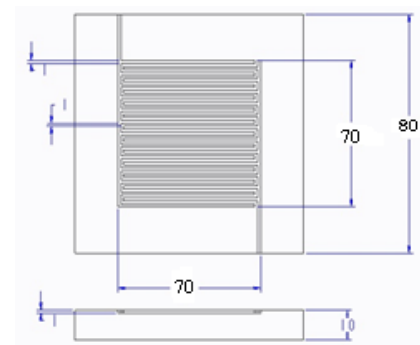

(a)

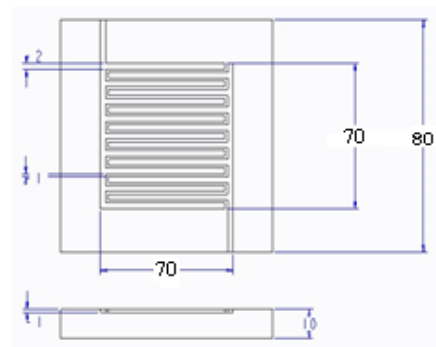

(b)

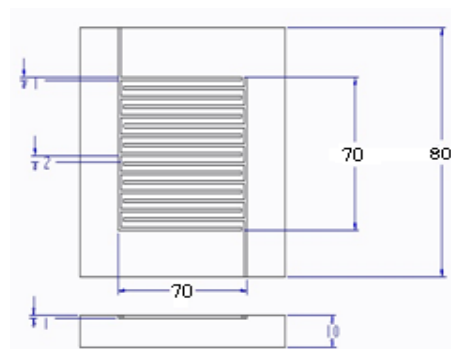

(c)

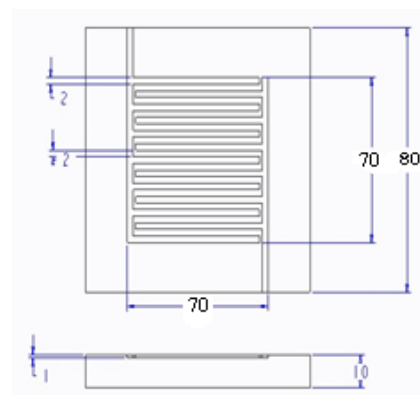

(d)

Fig -1: Various landing to channel width (L: C) (a) 1:1 (b) 1:2 (c) 2:1 and (d) 2:2 of interdigitated flow channel of 49 cm² active area of PEMFC

After geometry modeling, the next step was discretization of PEMFC done by ICEM software. The Cartesian grid meshing method was used, which is used in the formation of hexahedral mesh to attain accurate results. Split block method was used for blocking and body fitted mesh was used for meshing. The projection factor was set to 1 and the projection factor decides how closely the edges of the mesh match up with the grid.

The simulation of PEMFC was solved by simultaneous equations like conservation of mass, momentum, energy, species concentration, butler-Volmer equation, Joule heating reaction and the Nernst equation to obtain reaction kinetics. The model used to consider the system as 3-D, steady state and inlet gases as ideal condition, system as an isothermal and flow as laminar, fluid as incompressible, thermo physical properties as constant and the porous GDL, two catalyst layers and the membrane as an isotropic.

A control volume approach based on commercial solver FLUENT 14.5 was used to solve the various governing equations. Three-dimensional, double precision and serial processing were used for this model. The species concentration on anode side of H₂, O₂, and H₂O were set to 0.8, 0, and 0.2 respectively. Similarly, on the cathode side were set as 0, 0.2 and 0.1 respectively. The porosity at anode and cathode side was 0.5. Open circuit voltage was set at 0.95 V on the cathode and the anode was grounded. The cathode voltage has been varied from 0.05 V to 0.95 V used for solving kinetics reaction in order to get the current flux density H₂, O₂, and H₂O fractions along with the flow field design. Multigrid settings were modified as F-Cycle for all the equations and entered termination restriction value was set as 0.001 for H₂, O₂, H₂O and water saturation. The Anode and Cathode reference current density was set to be 10000 A/cm² and 20 A/cm² respectively. 0.1 kmol/m³ was set to anode and cathode reference concentration, Anode and cathode exchange coefficient was set to be 2. The Reference diffusivity of H₂, O₂ and H₂O was set to as 3E-5. The electric and proton potential values were set at 0.0001. Stabilization method BCGSTAB was selected for H₂, O₂, H₂O, water saturation, electric and proton potential.

Taguchi method of optimization has been used to find out the most optimum combination among the various input parameters which would result in getting the maximum possible output which causes the performance enhancement of PEMFC. The factors considered for the analysis were rib to channel ratios on interdigitated flow field design (L: C-1:1, 1:2, 2:1 and 2:2), pressure (1, 1.5, 2 and 2.5 bar), temperature (313, 323, 333 and 343 K), anode and cathode reactants as stoichiometric ratios (S/F) of 3, 3.5, 4 and 4.5. The standard L16 orthogonal array with 4-level and 4 factors was used and the parameters were considered as low, high and medium range values. When this orthogonal array was used, significance of factors and optimum combination can be found in 16 runs itself. The theoretical value of hydrogen in the anode side was 4.33E-07 kg/s and oxygen in the cathode side was 3.33E-06 kg/s.

3. RESULTS AND DISCUSSION

As per L16 orthogonal array, the inputs of 16 combination of various parameters were given to the Ansys CFD Fluent analysis software and having all other parameters constant. The obtained power densities from analysis software for all 16 runs were fed in to the Minitab 17 software. The corresponding Signal/Noise (S/N) ratios for all 16 combinations were found from Minitab 17 software itself as shown in the Table 2.

The landing to channel width ratio of 1:1 for interdigitated flow field has shown maximum power densities of 0.195 W/cm² and minimum power densities of 0.142 W/cm² respectively. Similarly for L:C of 1:2 and 2:1 having maximum power density of 0.203W/cm² and 0.161 W/cm² respectively. The minimum power densities for the same L:C ratios have 0.157W/cm² and 0.127 W/cm² respectively. For the landing to channel width ratio of 2:2 has shown maximum power density of 0.189 W/cm² and power density of 0.159 W/cm². The optimization was performed for "Larger the Better" type of Taguchi method since power output of PEMFC must be maximized. The S/N ratio plot for the same were obtained using Minitab 17 software and the corresponding maximum S/N ratio gives better performance as analyzed based on larger the better as shown in the Fig.2.

Table -2: Factors, levels, power density and S/N ratio for 16 runs of optimization

Ru n	R:C	Pr ess ure	Tempe rature	Stoi. Rati o	Power Density (W/cm ²)	S/N Ratio
1	1x 1	1	313	3	0.141	-16.9838
2		1.5	323	3.5	0.159	-15.9262
3		2	333	4	0.179	-14.9638
4		2.5	343	4.5	0.195	-14.1839
5	1x 2	1	323	4	0.169	-15.4043
6		1.5	313	4.5	0.157	-16.0978
7		2	343	3	0.203	-13.8341
8		2.5	333	3.5	0.197	-14.1025
9	2x 1	1	333	4.5	0.144	-16.8392
10		1.5	343	4	0.161	-15.8525
11		2	313	3.5	0.127	-17.8901
12		2.5	323	3	0.143	-16.8818
13	2x 2	1	343	3.5	0.189	-14.4271
14		1.5	333	3	0.187	-14.5604
15		2	323	4.5	0.175	-15.1536
16		2.5	313	4	0.159	-15.9489
Average S/N Ratio						-15.566

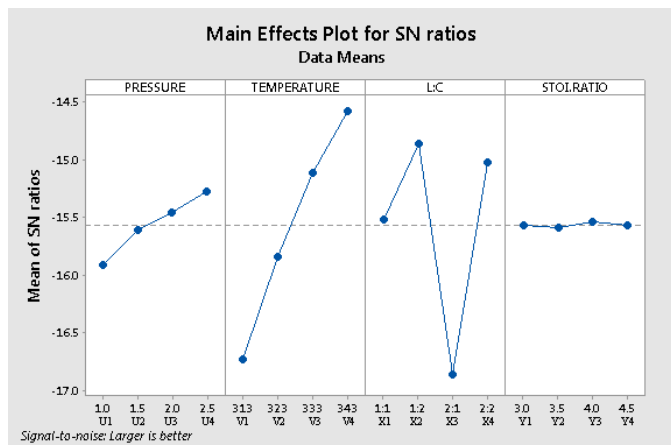

Fig.2. Mean S/N ratio plot for Pressure (U1-U4), Temperature (V1-V4), L:C (X1-X4), Stoi.Ratio (Y1-Y4)

Based on the result available from the Table 3, It was concluded that the design parameter such as, landing to channel width ratio of interdigitated flow channel having -1:2 as X2, and the operating parameters like pressure - 2.5 bar as U4, temperature - 343 K as V4, Stoichiometric ratio of inlet mass flow rate - 4 as Y3 were the optimum parameters to show the better PEMFC performance. The optimization results of various parameters were based on S/N ratios and the significance of each factor by ranking them according to their performance. Delta value of each factor available on the Minitab 17 software itself was shown in Table 3.

Table 3. Mean S/N ratios, Delta and Rank for each level of factors

Factors	Leve l1	Leve l2	Leve l3	Leve l4	Delt a	Ran k
Landing to Channel width (L:C)	- 15.5 1	- 14.8 6	- 16.8 7	- 15.0 2	2.01	2
Pressure (bar)	- 15.9 1	- 15.6 1	- 15.4 6	- 15.2 8	0.63	3
Temperatur e (K)	- 16.7 3	- 15.8 4	- 15.1 2	- 14.5 7	2.16	1
Stoi.Ratio	- 15.5 7	- 15.5 9	- 15.5 4	- 15.5 7	0.04	4

The factor with highest delta value indicates higher significance factor. It was found that the operating pressure was the predominant factor affecting the performance and it has been contributed as 45.24 % of overall performance of PEMFC. The other parameters were also influencing the performance to a considerable extent such as, landing to

channel width ratio (L:C) of interdigitated flow channel was to be 19.02%, stoichiometric ratio of inlet mass flow rate was 10.54% and operating temperature was to be 0.97% respectively. The combined effect of combination of pressure with temperature and pressure with L:C has shown 0.11 % and 16.95 % respectively contributing to peak power performance of the PEMFC. Also the percentage contribution of individual parameters, P-test and F-test on the interdigitated flow fields for the performance of PEMFC has been shown in the Table 4.

Table 4.The percentage contribution of individual parameters of interdigitated flow channel

Factors	D O F	Sum of square s	Varian ce	F-test	P- Tes t	Contri bution (%)
Pressure	2	0.000364	0.00018	910.08	0.076	45.24
Tempera ture	2	0.000808	0.00040	2020.96	0.018	0.97
Stoichio metric ratio	2	0.000014	0.00001	35.55	0.11	10.54
L:C	3	0.003189	0.00106	2659.64	0	19.02
Pressure & Tempera ture	1	0.000023	0.00002	58.26	0.017	0.11
Pressure & L:C	3	0.000008	0	6.28	0.14	16.95
Error	2	0.000001	0			7.17
Total	15	0.007708	0.001682167	5684.63	0.361	100

4. CONCLUSIONS

The maximum power density for optimizing the four different parameters on 49 cm² active area of interdigitated flow channel of PEMFC using CFD Fluent software was found to be 0.203 W/cm² from L:C-1:2 with 2 bar operating pressure, 343 K temperature and 3 stoichiometric ratio of inlet reactant gases and R² value was arrived 99.9 %. The maximum to minimum percentage of power deviation in 49 cm² interdigitated flow channel has found to be 59.8. The performance of PEMFC with various design and operating parameters has been affected considerably.

REFERENCES

- [1] Nicholas, S.;Siefert.; Shawn Litster.(2011).Voltage loss and fluctuation in proton exchange membrane fuel cells: The role of cathode channel plurality and air stoichiometric ratio, Journalof Power Sources, 196, 1948-1954.

- [2] Manso, A. P.;Garikano, X.;GarmendiaMujika, M.(2012). Influence of geometric parameters of the flow fields on the performance of a PEM fuel cell, A review International Journal of Hydrogen Energy, 37,15256-15287.
- [3] Lakshminarayanan V, Karthikeyan P, Kiran Kumar DS and Dhilip Kumar SM K. Numerical analysis on 36cm² PEM fuel cell for performance enhancement, ARPN Journal of Engineering and Applied Sciences, 2016, 11, no. 2.
- [4] Guvelioglu, GH & Stenger, HG 2005, 'Computational fluid dynamics modeling of polymer electrolyte membrane fuel cells', Journal of Power Sources, vol. 147, no. 1, pp. 95-106.
- [5] Ahmed, DH & Sung, HJ 2006, 'Effects of channel geometrical configuration and shoulder width on PEMFC performance at high current density', Journal of Power Sources, vol. 162, no. 1, pp. 327-339.
- [6] Lakshminarayanan V & Karthikeyan P. Optimization of Flow Channel Design and Operating Parameters on Proton Exchange Membrane Fuel Cell Using Mat lab. Periodica Polytechnica Chemical Engineering. Budapest Univ Technology Economics. 2016, 60, 3; 173-180.
- [7] Grujicic, M & Chittajallu, K 2004, 'Design and optimization of polymer electrolyte membrane (PEM) fuel cells', Applied surface science, vol. 227, no. 1, pp. 56-72.
- [8] Karthikeyan, P, Muthukumar, M, Shanmugam, SV, Kumar, PP, Murali, S & Kumar, AS 2013, 'Optimization of Operating and Design Parameters on Proton Exchange Membrane Fuel Cell by using Taguchi method', Procedia Engineering, vol. 64, pp. 409-418.
- [9] Wu, S-J, Shiah, S-W & Yu, W-L 2009, 'Parametric analysis of proton exchange membrane fuel cell performance by using the Taguchi method and a neural network', Renewable Energy, vol. 34, no. 1, pp. 135-144.
- [10] Yan WM, Chen CY, Mei SC, Soong CY & Chen F. 'Effects of operating conditions on cell performance of PEM fuel cells with conventional or interdigitated flow field, Journal of Power Sources,2006, 162, no. 2; 1157-1164.