

Investigation Effect of Outage Line on the Transmission Line for Karbalaa-132Kv Zone in Iraqi Network

¹ **Rashid H. AL-Rubayi** & Department of Electrical Engineering, University of Technology

² **Afaneen A. Abood** & Department of Electrical Engineering, University of Technology

³ **Mohammed R. Saeed AL-hendawi** & Department of Electrical Engineering, University of Technology

Abstract - System security includes practices designed to keep the system running when components fail. Bullets to be ejected by automatic relay may storm the damage transfer line. If the appropriate commitment to transmission flows is maintained when the transmission and generation obligation is maintained, the remaining transmission lines can take the increasing load while remaining within the limits. Because the specific times that start events that cause components to fail are unpredictable, the system must be operated at all times in such a way that the system will not leave in a serious situation in the event of any event initiating credibility. Power system equipment is designed to operate within certain limits. Automatic devices that can cause equipment to be transferred from the system if these limits are violated protect most pieces of equipment. In the event that an event occurs on a system that leaves it working at a violation limit, the event may be followed by a series of other actions that switch the other equipment out of service. If this process continues with successive failures, the entire system or large parts of it may collapse completely. In this paper, it has been building simulation program to study the cases outage lines of the karbalaa-132kV network system. Tow cases adopted for the purposes of the study. Where study and discuss those cases in detail and its impact on network performance. It was diagnosed lines, which causes increased power flow over the limit in addition to the reflection of the other feeding lines.

Key Words:- contingency analysis; dc power flow; power system security.

1.INTRODUCTION

The DC power flow simplifies the power flow by making a number of approximations including 1) completely ignoring the reactive power balance equations, 2) assuming all voltage magnitudes are identically one per unit, 3) ignoring line losses and 4) ignoring tap dependence in the transformer reactance. Hence, the dc power flow reduces the power flow problem to a set of linear equations. The dc solution load value has increased to match the total ac load plus losses, a manner to make comparison between the ac and dc solution results possible. The effectiveness of the method developed is identified through its application to the karbalaa-132kV network system..

2. DC POWER FLOW ALGORITHM

AC power flow algorithms have high calculation precision but do not have fast speed. In real power dispatch or power market analysis, the requirement of calculation precision is not very high, but the requirement of calculation speed is of most concern, especially for a large - scale power system. More simplification power flow algorithms than fast decoupled power flow algorithms are used. One algorithm is called "MW Only". In this method, the Q - V equation in the fast decoupled power flow model is completely dropped. Only the following P - θ equation is used to correct the angle according to the real power mismatch.

$$\begin{bmatrix} \Delta P_1 \\ V_1 \\ \Delta P_2 \\ V_2 \\ \vdots \\ \Delta P_{n-1} \\ V_{n-1} \end{bmatrix} = \begin{bmatrix} -B_{11} & -B_{12} & -B_{13} \\ -B_{21} & -B_{22} & -B_{23} \\ \vdots & \vdots & \vdots \\ -B_{n-1,1} & -B_{n-1,2} & -B_{n-1,n-1} \end{bmatrix} \begin{bmatrix} \Delta \theta_1 \\ \Delta \theta_2 \\ \vdots \\ \Delta \theta_{n-1} \end{bmatrix} \dots(1)$$

In the MW - only power flow calculation, the voltage magnitude can be handled either as constant or as 1.0 during each P - θ iteration. For the convergence, only real power mismatch is checked no matter what the reactive power mismatch is. Another most simplified power flow algorithm is DC power flow. It is also an MW - only method but has the following assumptions:

- (1) All the voltage magnitudes are equal to 1.0.
- (2) Ignore the resistance of the branch; i.e., the susceptance of the branch is

$$B_{ij} = -\frac{1}{x_{ij}} \dots(2)$$

- (3) The angle difference on the two ends of the branch is very small, so that we

$$\sin\theta_{ij} = \theta_i - \theta_j$$

$$\cos\theta_{ij} = 1$$

- (4) Ignore all ground branches; that is,

$$B_{i0} = B_{j0} = 0$$

$$\cos\theta_{ij} = 1$$

Therefore, the DC power flow model will be

$$\begin{bmatrix} \Delta P_1 \\ \Delta P_2 \\ \vdots \\ \Delta P_{n-1} \end{bmatrix} = [B'] \begin{bmatrix} \Delta \theta_1 \\ \Delta \theta_2 \\ \vdots \\ \Delta \theta_{n-1} \end{bmatrix} \dots (3)$$

Or

$$[\Delta P] = [B'][\Delta \theta] \dots\dots (4)$$

Where: B' matrix are the same as those in the XB version of fast decoupled power flow but we ignore the matrix B''.

That is,

$$B'_{ij} = -\frac{1}{x_{ij}} \dots\dots (5)$$

$$B'_{ij} = -\sum_{j \neq i} B'_{ij} \dots\dots (6)$$

The DC power flow is a purely linear equation, so only one iteration calculation is needed to obtain the power flow solution. However, it is only good for calculating real power flows on transmission lines and transformers. The power flowing on each line using the DC power flow is then

$$P_{ij} = -B_{ij}(\theta_i - \theta_j) = \frac{\theta_i - \theta_j}{x_{ij}} \dots\dots(7)$$

3. SENSITIVITY FACTOR MATRICES CALCULATION

The sensitivity analyses are becoming more and more important in practical power system operations including in power market operations. These are analyzes and discusses all kinds of sensitivity factors such as loss sensitivity factor, generator shift factor (GSF), constraint shift factor, line outage distribution factor (LODF) and response factor for the transfer path. It also addresses the practical application of these sensitivity factors including a practical method to convert the sensitivities with different references. The power operator uses these to study and monitor market and system behavior and detect possible problems in the operation. These sensitivity calculations are also used to determine whether the online capacity as indicated in the resource plan is located in the right place in the network to serve the forecasted demand. If congestion or violation exists, the generation scheduling based on the sensitivity calculations can determine whether or not a different allocation of the available resources could resolve the congestion or violation problem [3].

The problem of studying thousands of possible outages becomes very difficult to solve if it is desired to present the

results quickly. One of the easiest ways to provide a quick calculation of possible overloads is to use linear sensitivity factors. These factors show the approximate change in line flows for changes in generation on the network configuration and are derived from the DC load flow presented in the flowing steps. These factors can be derived in a variety of ways and basically come down to two types [3]:

1. Generation shift factors.
2. Line outage distribution factors.

Setp1:- Now calculate the Y_{bus} from impedance x_{ij} as equation

$$y_{ij} = -\frac{1}{x_{ij}} \dots\dots(8)$$

$$y_{ii} = \sum_{j=1}^n y_{ij} \quad i \neq j \dots\dots(9)$$

We gets

$$Y_{bus} = \begin{bmatrix} y_{11} & y_{12} & \dots & y_{1n} \\ y_{21} & \ddots & \dots & y_{2n} \\ \vdots & \vdots & \ddots & \vdots \\ y_{n1} & y_{n2} & \dots & y_{nn} \end{bmatrix} \dots\dots(10)$$

Step2:- Since bus one is a slack bus and eliminate (1st row & the 1st column) from matrix in equation (10). We get

$$Y_{eliminate} = \begin{bmatrix} y_{22} & y_{23} & \dots & y_{2n} \\ y_{32} & \ddots & \dots & y_{3n} \\ \vdots & \vdots & \ddots & \vdots \\ y_{n2} & y_{n3} & \dots & y_{nn} \end{bmatrix} \dots\dots(11)$$

Step3:- Find the inverse of $Y_{eliminate}$, we gets

$$M = Y_{eliminate}^{-1} \dots\dots(12)$$

Step4:- Determine the sensitivity matrix by :

$$X = \begin{bmatrix} 0 & 0 \\ 0 & M \end{bmatrix} \dots\dots(13)$$

Step5:- Determine the generation shift sensitivity factor by performing the outage of the generation connected to selected bus (k) with connected line (l) from the following equation:

$$a_{ll,k} = \frac{1}{x_l} (X_{nk} - X_{mk}) \dots\dots(14)$$

Step6:- Determine of the line outage distribution sensitivity factor by performing the outage of the line connected to bus is called (kk) that affected on the line in bus another line is called (ll) from the following equation:

$$d_{ll,kk} = \frac{x_{kk}(x_{in} - x_{jn} - x_{im} + x_{jm})}{x_{ll}(x_{kk} - (x_{ii} + x_{jj} - 2x_{ij}))} \dots\dots (15)$$

The generation shift factors are designated ($a_{li,i}$) and have the following definition:

$$a_{ll,i} = \frac{\Delta f_{ll}}{\Delta P_i} \dots\dots (16)$$

Where:

ll = line index.

i = bus index.

Δf_{ll} = change in megawatt power flow on line ll

when a change in generation, ΔP_i occurs at bus i .

ΔP_i = change in generation at bus i .

It is assumed in this definition that the change in generation, ΔP_i , is exactly compensated by an opposite change in generation at the reference bus, and that all other generators remain fixed. The $a_{ll,i}$ factor then represents the sensitivity of the flow on line ll to a change in generation at bus i . Suppose one wanted to study the outage of a large generating unit and it was assumed that all the generation lost would be made up by the reference generation (we will deal with the case where the generation is picked up by many machines shortly). If the generator in question was generating P_i^o MW and it was lost, we would represent ΔP_i , as [4]:

$$\Delta P_i = -P_i^o \dots\dots (17)$$

And the new power flow on each line in the network could be calculated using a pre calculated set of "a" factors as follows:

$$f_{ll} = f_{ll}^o + a_{ll,i} \Delta P_i \text{ for } ll = 1 \dots LL \dots\dots(18)$$

Where:

f_{ll} = flow on line ll after the generator on bus i fails.

f_{ll}^o = flow before the failure.

The "outage flow," f_{ll} on each line can be compared to its limit and those exceeding their limit flagged for alarming. This would tell the operations personnel that the loss of the generator on bus i would result in an overload on line ll .

The line outage distribution factors are used in a similar manner; only they apply to the testing for overloads when transmission circuits are lost. By definition, the line outage distribution factor has the following meaning:

$$d_{ll,k} = \frac{\Delta f_{ll}}{f_k^o} \dots\dots (19)$$

$d_{ll,k}$ = line outage distribution factor when monitoring line l after an outage on line k .

Δf_{ll} = change in MW flow on line l .

f_k^o = original flow on line k before it was outaged (opened).

If one knows the power on line ll and line k , the flow on line ll with line k out can be determined using "d" factors.

$$f_{ll} = f_{ll}^o + d_{ll,k} f_k^o \dots\dots (20)$$

Where:

$f_{ll}^o \cdot f_k^o$ = preoutage flows on lines ll and k , respectively.

f_{ll} = flow on line ll with line k out.

4. RESULT and DISCUSSION:

The line and bus data of the karbalaa-132kV network. The system input data is shown in tables (1, 2, 3, 4 & 5), and figures (1, 2 & 3).

Table 1: Name Bus in Iraqi Network and Present Work

From Bus		To Bus			
In Iraqi Network		In Present Work	In Iraqi Network		In Present Work
Number	Name	Number	Number	Name	Number
20302	MUS3 132.00	4	21303	KBLN 132.00	5
20302	MUS3 132.00	4	21310	KRBE 132.00	2
20313	BAB3 132.00	3	21311	HNDS 132.00	8
20313	BAB3 132.00	3	21311	HNDS 132.00	8
21301	AKDC 132.00	7	21303	KBLN 132.00	5
21301	AKDC 132.00	7	21303	KBLN 132.00	5
21302	KRBL 132.00	9	21304	KBLW 132.00	6
21302	KRBL 132.00	9	21304	KBLW 132.00	6
21302	KRBL 132.00	9	21311	HNDS 132.00	8
21302	KRBL 132.00	9	21311	HNDS 132.00	8
21303	KBLN 132.00	5	21304	KBLW 132.00	6
21303	KBLN 132.00	5	21305	KRBLG 132.00	1
21303	KBLN 132.00	5	21310	KRBE 132.00	2
21304	KBLW 132.00	6	21305	KRBLG 132.00	1

Table 2: Line Data

Branch No.	From Bus	To Bus	Line R (pu)	Line X (pu)
1	1	5	0.009904	0.055415
2	1	6	0.007533	0.042147
3	2	5	0.003488	0.021525
4	3	8	0.002887	0.01615
5	3	8	0.002887	0.01615
6	4	2	0.010114	0.062422
7	4	5	0.013392	0.074928
8	5	6	0.002464	0.015205
9	5	7	0.04951	0.19767
10	5	7	0.04951	0.19767
11	6	9	0.002371	0.013269
12	6	9	0.002371	0.013269
13	8	9	0.005679	0.035053
14	8	9	0.005679	0.035053

5	Load	0.967	228.9	0		
6	Load	0.971	61.2	0		
7	Load	0.948	33.4	0		
8	Load	0.991	36.1	0		
9	Load	0.974	91	0		

Table 5: Power Flow through Branches for The Karbalaa-132kV Network

Branch No.	Line	MW Limit	MW From	MW To	Percentage from limit
1	1-5	188.8	39.7	39.6	21.03%
2	1-6	188.8	58.9	58.6	31.20%
3	2-5	188.8	186.7	185.4	98.89%
4	3-8	188.8	56.1	55.9	29.71%
5	3-8	188.8	56.1	55.9	29.71%
6	4-2	188.8	1.5	1.5	0.79%
7	4-5	188.8	56.5	55.9	29.93%
8	5-6	188.8	18.2	18.2	9.64%
9	5-7	98.4	16.9	16.9	17.17%
10	5-7	98.4	16.9	16.9	17.17%
11	6-9	188.8	7.8	7.8	4.13%
12	6-9	188.8	7.8	7.8	4.13%
13	8-9	188.8	37.9	37.7	20.07%
14	8-9	188.8	37.9	37.7	20.07%

Table 3: Limit and Length Line Data on The Transmission Line

Branch No.	From Bus	To Bus	Limit (MVA)	Limit (MW)	Length (Km)
1	1	5	236	188.8	35.5
2	1	6	236	188.8	27
3	2	5	236	188.8	12.5
4	3	8	236	188.8	10.346
5	3	8	236	188.8	10.346
6	4	2	236	188.8	36.25
7	4	5	236	188.8	48
8	5	6	236	188.8	8.83
9	5	7	123	98.4	89
10	5	7	123	98.4	89
11	6	9	236	188.8	8.5
12	6	9	236	188.8	8.5
13	8	9	236	188.8	20.356
14	8	9	236	188.8	20.356

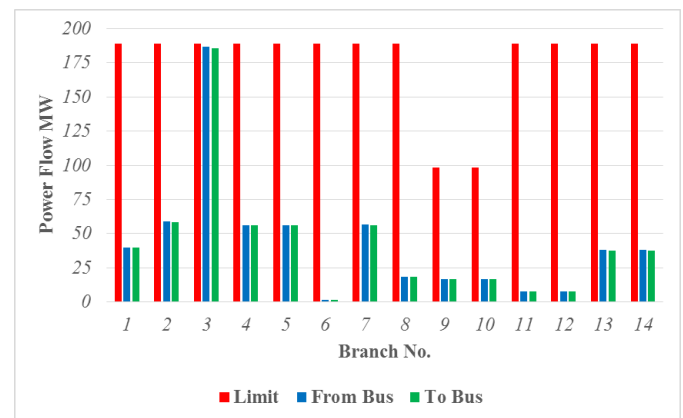

Figure 1: Power Flow through Branches for The Karbalaa-132kV Network

Table 4: Bus Data

Bus Number	Bus Type	Voltage Schedule (pu)	Power load (MW)	Power gen. (MW)	Max. Power gen. (MW)	Min. Power gen. (MW)
1	Swing	0.976	54.2	152.8	260	30
2	Gen.	0.98	70.2	255.6	300	30
3	Gen.	1	0	112.2	180	0
4	Gen.	1	0	58	132	0

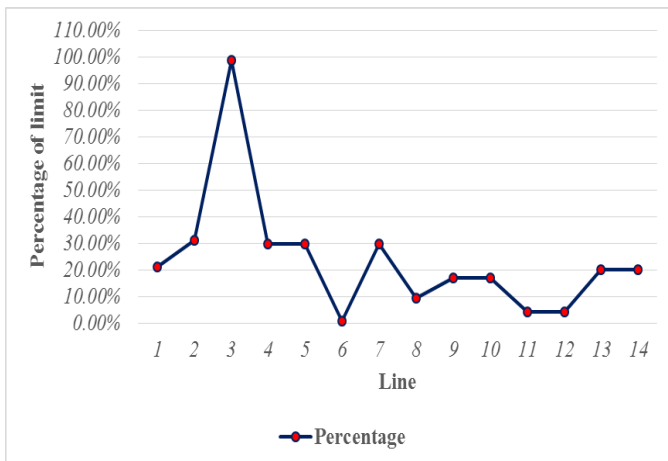

Figure 2: Branch Percentage Limit for The Karbalaa-132kV Network

The start simulator program (the mathematic mode that discussed in item 3) output results could be which depends based on the following steps:-

Step 1:- Sensitivity Factor Matrices (SFM)

The sensitivity factor matrices were determined in the simulation program. It was to get the results as shows in the table 6.

Table 6: SFM for the Karbalaa-132kV Network

0	0	0	0	0	0	0	0	0
0	0.0468	0.0207	0.0383	0.0282	0.0207	0.0282	0.0207	0.0207
0	0.0207	0.0586	0.0207	0.0207	0.0264	0.0207	0.0506	0.0330
0	0.0383	0.0207	0.0678	0.0282	0.0207	0.0282	0.0207	0.0207
0	0.0282	0.0207	0.0282	0.0282	0.0207	0.0282	0.0207	0.0207
0	0.0207	0.0264	0.0207	0.0207	0.0264	0.0207	0.0264	0.0264
0	0.0282	0.0207	0.0282	0.0282	0.0207	0.1270	0.0207	0.0207
0	0.0207	0.0506	0.0207	0.0207	0.0264	0.0207	0.0506	0.0330
0	0.0207	0.0330	0.0207	0.0207	0.0264	0.0207	0.0330	0.0330

Step 2:- Generator Shift Factor (GSF)

The generator shift factor was determined in the simulation program. It was to get the results as shows in the table 7.

Table 7: GSF for the Karbalaa-132kV Network

Line	Bus 1	Bus 2	Bus 3	Bus 4
1-5	0	-0.5086	-0.3738	-0.5086
1-6	0	-0.4914	-0.6262	-0.4914
2-5	0	0.8645	0	0.4716
3-8	0	0	1	0
4-2	0	-0.1355	0	0.4716
4-5	0	0.1355	0	0.5284
5-6	0	0.4914	-0.3738	0.4914
5-7	0	0	0	0
6-9	0	0	-1	0
8-9	0	0	1	0

Step 3:- Line Outage Distribution Factor (LODF)

The line outaged distribution factor was determine by simulation program. It was to get the results as shows in the table 8.

Table 8: GSF for the Karbalaa-132kV Network

Line	1-5	1-6	2-5	3-8	4-2	4-5	5-6	5-7	6-9	8-9
1-5		1	0	0	0	0	-1	0	0	0
1-6	1		0	0	0	0	1	0	0	0
2-5	0	0		0	-1	1	0	0	0	0
3-8	0	0	0		0	0	0	0	0	0
4-2	0	0	-1	0		1	0	0	0	0
4-5	0	0	1	0	1		0	0	0	0
5-6	-1	1	0	0	0	0		0	0	0
5-7	0	0	0	0	0	0	0		0	0
6-9	0	0	0	0	0	0	0	0		0
8-9	0	0	0	0	0	0	0	0	0	

The simulation program was use to study multi cases of line outage for karbalaa-132kV network as follows:-

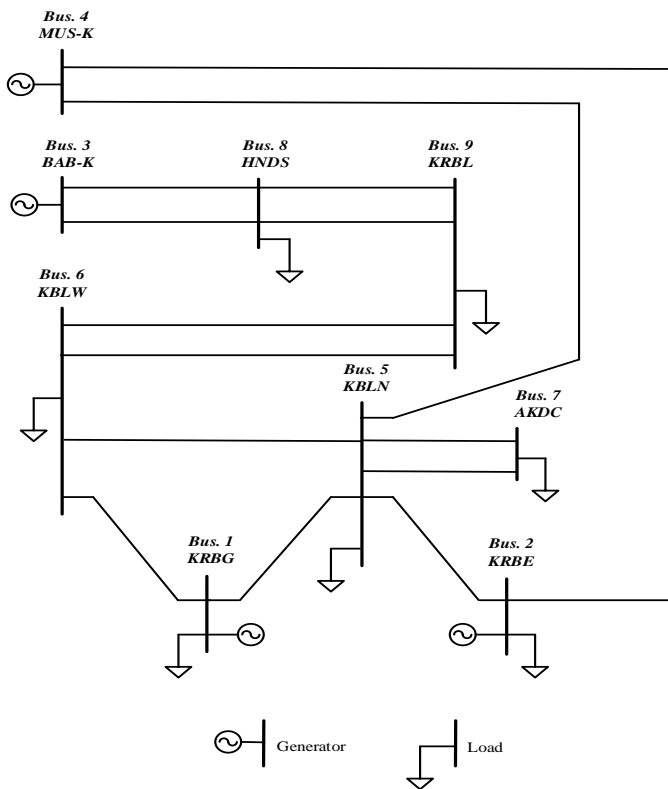

Figure 3: Karbalaa-132kV network

Case 1: (4-5) outage line

When the line (4-5) have outaged, the power flow will be redistribution on other lines as shown in table (9) and figure (4 & 5). It was noticed that was existing problems by outaged this line such as over power flow at line (2-5) with a percentage value of 128.81% of its limit.

For treatment the over power flow at line (2-5), the correction factor at generation bus-2 (KRBE) was chosen with value of (-62.93 MW). On other side, the decrement was taken at generator unit which to be connected at the same bus of value (192.67 MW); whereas this value within range. The percentage decrement 75.38% of the real value of (255.6 MW). In addition to above, the same value was increased at generation slack bus (KRBG), the redistributed of power flow after treatment the over load with outage line (4-5) as shown in table (10), Figures (6 & 7).

Case 2: (2-5) outage line

When the line (2-5) have outaged, the power flow will be redistributed on other lines as shown in table (11), figure (8 & 9). It was noticed that was existing problems by outaged this line such as over power flow at line (4-5) with a percentage value of 128.81%.

For treatment the over power flow at line (4-5), the correction factor at generation bus-2 (KRBE) was chosen

with value of (-401.52 MW). On other side, the decrement was taken at generator unit which to be connected at the same bus of value under minimum generation; This value impossible to be used to treat over power flow at these lines because the generation at bus-2 (KRBE) would not within range of the generator constraints.

Table 9: Power Flow at Outage Line (4-5)

Branch No.	Line	MW Limit	Before Outage (4-5)			After Outage (4-5)			State of branch
			MW From	MW To	Percentage from limit	MW From	MW To	Percentage from limit	
1	1-5	188.8	39.7	39.6	21.03%	39.7	39.6	21.03%	
2	1-6	188.8	58.9	58.6	31.20%	58.9	58.6	31.20%	
3	2-5	188.8	18.7	18.5	98.89%	24.3	24.1	128.81%	over flow
4	3-8	188.8	56.1	55.9	29.71%	56.1	55.9	29.71%	
5	3-8	188.8	56.1	55.9	29.71%	56.1	55.9	29.71%	
6	4-2	188.8	1.5	1.5	0.79%	58.4	57.4	30.72%	
7	4-5	188.8	56.5	55.9	29.93%	0	0	0.00%	outage
8	5-6	188.8	18.2	18.2	9.64%	18.2	18.2	9.64%	
9	5-7	98.4	16.9	16.9	17.17%	16.9	16.7	17.17%	
10	5-7	98.4	16.9	16.9	17.17%	16.9	16.7	17.17%	
11	6-9	188.8	7.8	7.8	4.13%	7.8	7.8	4.13%	
12	6-9	188.8	7.8	7.8	4.13%	7.8	7.8	4.13%	
13	8-9	188.8	37.9	37.7	20.07%	37.9	37.7	20.07%	
14	8-9	188.8	37.9	37.7	20.07%	37.9	37.7	20.07%	

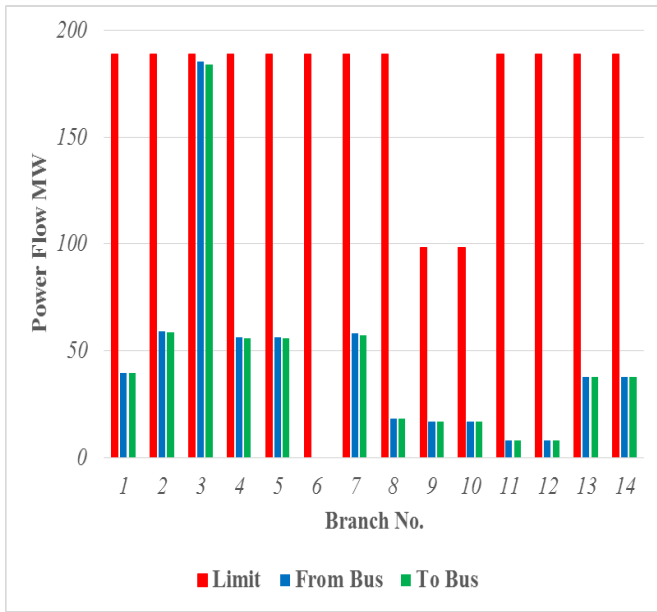

Figure 4: Power flow at an outaged line of (4-5)

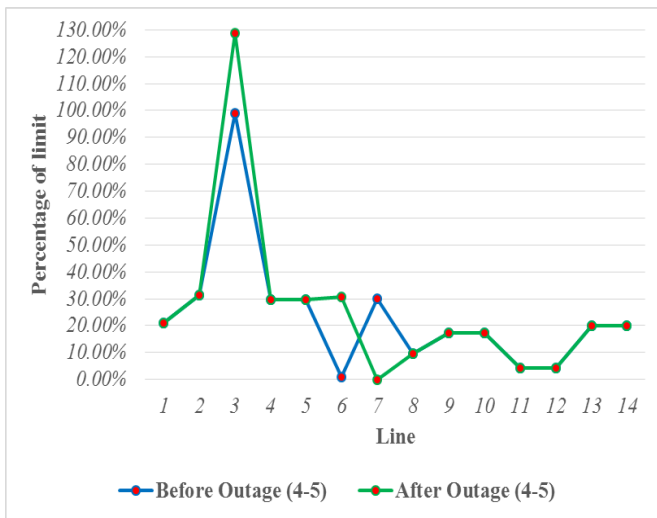

Figure 5: Branch percentage limit at an outaged line (4-5)

Table 10: Power Flow after Treatment with Outage Line (4-5)

Branch No.	Line	MW Limit	Outage (4-5) Before Treatment			State of branch	Outage (4-5) After Treatment			State of branch
			MW From	MW To	ge from		MW From	MW To	ge from	
1	1-5	188.8	39.7	39.6	21.03 %		71.7	71.6	37.98 %	
2	1-6	188.8	58.9	58.6	31.20 %		89.8	89.5	47.58 %	
3	2-5	188.8	243	241	128.8 1%	over flow	189	187	100.0 0%	
4	3-8	188.8	56.1	55.9	29.71 %		56.1	55.9	29.71 %	
5	3-8	188.8	56.1	55.9	29.71 %		56.1	55.9	29.71 %	
6	4-2	188.8	58	57.4	30.72 %		66.5	65.9	35.24 %	
7	4-5	188.8	0	0	0.00 %	outage	0	0	0.00 %	outage
8	5-6	188.8	18.2	18.2	9.64 %		-13	-13	6.74 %	reverse
9	5-7	98.4	16.9	16.7	17.17 %		16.9	16.7	17.17 %	
10	5-7	98.4	16.9	16.7	17.17 %		16.9	16.7	17.17 %	
11	6-9	188.8	7.8	7.8	4.13 %		7.8	7.8	4.13 %	
12	6-9	188.8	7.8	7.8	4.13 %		7.8	7.8	4.13 %	
13	8-9	188.8	37.9	37.7	20.07 %		37.9	37.7	20.07 %	
14	8-9	188.8	37.9	37.7	20.07 %		37.9	37.7	20.07 %	

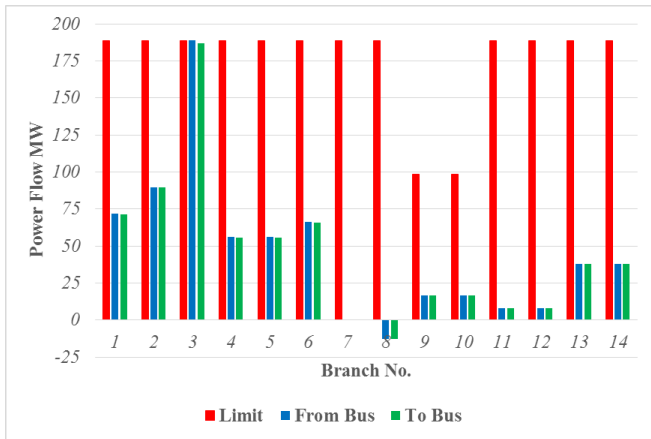

Figure 6: Power flow after treatment with an outaged line of (4-5)

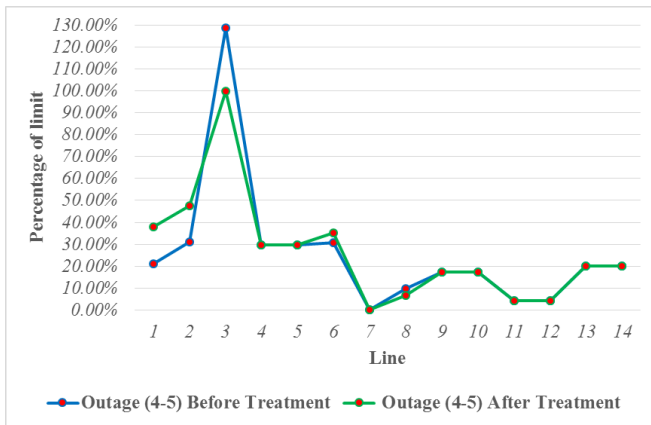

Figure 7: Branch percentage limit after treatment with an outaged line of (10-9)

Table 11: Power Flow at Outage Line (2-5)

Branch No.	Line	MW Limit	Before Outage (2-5)			After Outage (2-5)			State of branch
			MW From	MW To	Percentage from	MW From	MW To	Percentage from	
1	1-5	188.8	39.7	39.6	21.03 %	39.7	39.6	21.03 %	
2	1-6	188.8	58.9	58.6	31.20 %	58.9	58.6	31.20 %	
3	2-5	188.8	187	185	98.89 %	0	0	0.00 %	outage

4	3-8	188.8	56.1	55.9	29.71 %	56.1	55.9	29.71 %	
5	3-8	188.8	56.1	55.9	29.71 %	56.1	55.9	29.71 %	
6	4-2	188.8	1.5	1.5	0.79 %	-185	-184	98.09 %	reverse
7	4-5	188.8	56.5	55.9	29.93 %	243	241	128.8 %	overflow
8	5-6	188.8	18.2	18.2	9.64 %	18.2	18.2	9.64 %	
9	5-7	98.4	16.9	16.9	17.17 %	16.9	16.7	17.17 %	
10	5-7	98.4	16.9	16.9	17.17 %	16.9	16.7	17.17 %	
11	6-9	188.8	7.8	7.8	4.13 %	7.8	7.8	4.13 %	
12	6-9	188.8	7.8	7.8	4.13 %	7.8	7.8	4.13 %	
13	8-9	188.8	37.9	37.7	20.07 %	37.9	37.7	20.07 %	
14	8-9	188.8	37.9	37.7	20.07 %	37.9	37.7	20.07 %	

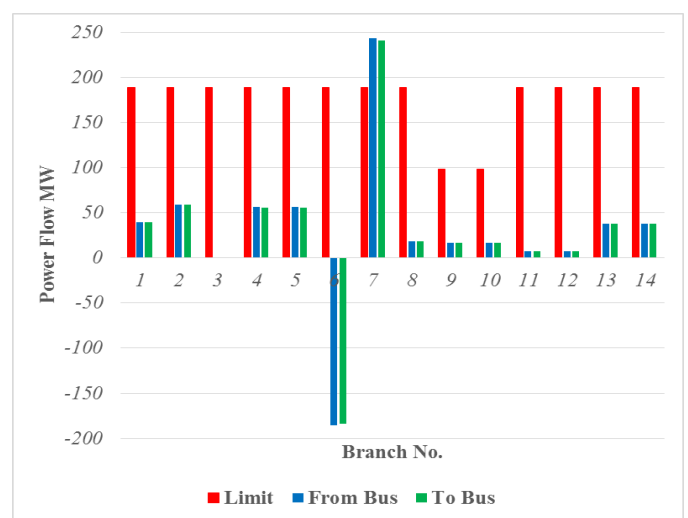

Figure 8: Power flow at an outaged line of (2-5)

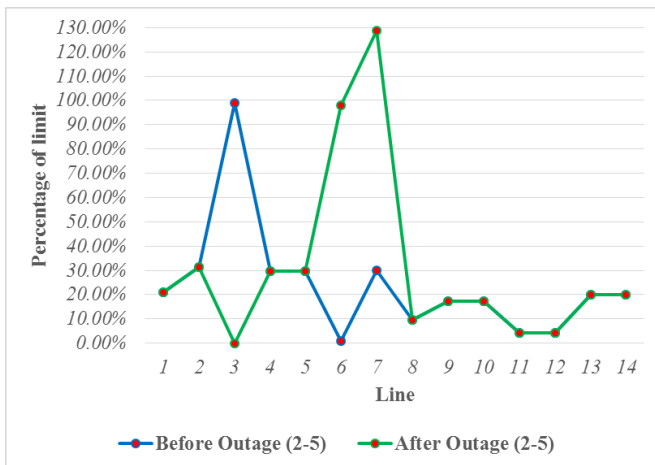

Figure 9: Branch percentage limit at an outaged line (2-5)

5. CONCLUSION

Through study and discussion out power flow lines for ensuring the network system, we suggest the following:

1. Control through regeneration organization in Buses.
2. Taking into consideration when designing the network system to the limits Permitted to lines of power flow to avoid a collapse in the network system.
3. Add lines to power flow in parallel-diagnosed lines, which happens rise in the power flow outside the limit to avoid weaknesses in the design of system network.
4. Add secondary line of power flow parallel to the main lines of power flow to avoid the outage occur frequently in some lines.

REFERENCES

- [1] J.Z. Zhu, "Power System Optimal Operation," Tutorial of Chongqing University, 1990.
- [2] Y. He, Z.Y. Wen, F.Y. Wang, and Q.H. Zhou, Power Systems Analysis, Huazhong Polytechnic University Press, 1985.
- [3] A. Keyhani, A. Abur, and S. Hao, "Evaluation of Power Flow Techniques for Personal Computers," IEEE Trans. on Power System, Vol. 4, No. 2, 1989, pp. 817 – 826.
- [4] O. Alsac and B. Stott, "Fast Decoupled power flow," IEEE Trans. on Power System, Vol. 93, 1974, pp. 859 – 869.
- [5] R.A.M. Van Amerongen, "A General Purpose Version of the Fast Decoupled power flow," IEEE Summer Meeting, 1988.

[6] A. Monticelli, A. Garcia, and O.R. Saavedra, "Decoupled power flow: Hypothesis, Derivations, and Testing," IEEE Trans. on Power System, Vol. 5, No. 4, 1990, pp. 1425 – 1431.

BIOGRAPHY:



Rashid H. AL-Rubayi
Department of Electrical Engineering, University of Technology



Afaneen A. Abood
Department of Electrical Engineering, University of Technology



Mohammed R. Saeed AL-hendawi
Department of Electrical Engineering, University of Technology