

REAL-TIME MONITORING, CONTROL & PROTECTION OF TRANSFORMER USING PLC AND SCADA

Akansha Dubey¹, Dr. Jyoti Shrivastava²

¹M.tech (Power System), Shuats, Allahabad, India

²Assistant Professor, Electrical Engineering Dept., Shuats, Allahabad, India

Abstract—Distribution transformers of substation are one of most important equipment in power system network. Because of, the large number of transformers and various components over a wide area in power system, the data acquisition, condition monitoring, automatic controlling are the important issues. By making use of a smart transformer we can monitor and control an entire substation. In this paper automation is done using PLC & SCADA using wireless system technologies system. PLC (Programmable Logical Controller) plays crucial role in automation field where many process are automated. On the other hand SCADA (Supervisory Control and Data Acquisition) act as human interfacing medium with machine where voltage, current and temperature fluctuation are monitored and corrected if necessary.

Keywords: Distribution Transformers, Monitoring, PLC Automation, SCADA, Relays, Sensors, Transducers, Ladder Logic.

I. INTRODUCTION

In modern age, automation has been placed on power reliability and economy. A power transformer is a very valuable and important link in a power transmission system. A monitoring is essential to evaluate transformer performance and safe operating conditions. High reliability of the transformer is essential to avoid disturbances in transmission of power. Due to wide range of PLC automation, the various types of fault in power transformer can be detected and diagnosed by using PLC system. [1] shows that transformer protection is a challenge to researchers. [1][2] discusses protection applications of the in-line transformers where a transmission line of power system terminates on a transformer and a single protection zone includes both the line as well as the transformer.

A high quality power transformer properly designed and supplied with suitable protective relays and monitors is very reliable. When a fault occurs in a transformer of electrical substation, the damage is normally severe due to high rating of power. The ultimate aim is that to minimize the response time after occurring fault. [3] presents an innovative design to develop a system which is based on AVR microcontroller that is used for logging the voltage, current and temperature of a power transformer in a substation and to protect the system

from any uncertainty conditions. [4] represents the protection of transformer using PLC. That paper not focus on monitoring and controlling of the faults. A power transformer requires regular maintenance and proper supervision. As if now operators and technicians are responsible for every process. Sometime there will be a big gap between request of process and response. This delay may cause failure of components connected to transformers and hence interruption of process. Through this project, we can achieve smart controlling technique in the emerging field of automation. PLC and SCADA controls the entire substation well

The proposed system should be efficient and can be effectively used:

- To reduce operation cost and Operating time of substation process.
- To achieve reliable operation.
- To make automated operation.
- For Data logging, which helps in analyzing the fault time.

II. HARDWARES USED

A. SINGLE PHASE SUPPLY (220/24V)

It is used to step down single phase transformer as rating of 230V/24V.

B. RELAY(24V):

One electromechanical relay which are connected in single phase connection of primary winding of transformer. Three electromechanical relays is placed on each load

C. SENSOR:

In this project we use three types of sensor such as voltage sensor, current sensor and temperature sensor.

D. RECTIFIER CIRCUIT :

This circuit is used to supply to sensors. This circuit is converted from 24V AC to 24V DC.

E. LOAD :

For convenient and reliable operation of this project, we are used to three 24 V DC bulb which are connected to rectifier output (24V DC).

F. PLC SYSTEM :

In this project, Analog PLC system is used to Programmable Logic Controller of Allen Bradley series micrologix 1000 of Rockwell

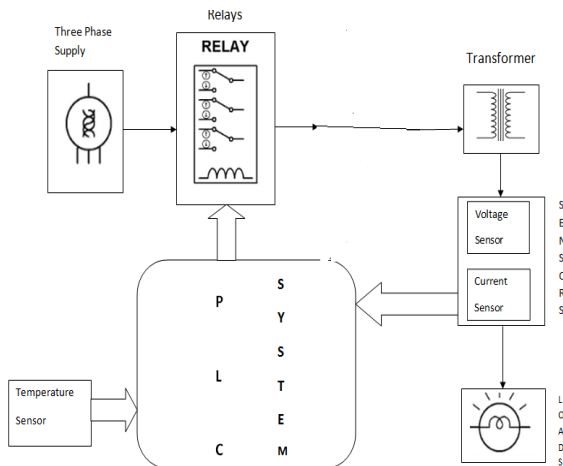

Fig.1 Block diagram of the proposed project

III. DESIGN OF PLC BASED TRANSFORMER FAULT DETECTION

The schematic block diagram of this model has been shown in fig.-1. It consists of different blocks lines. This relays are used in two ways. First way is that it will trip the main circuit when any fault occurs. And second way is that PLC will check continuously to main current. If phase to phase fault will occur then relay trips the circuit automatically. In the case study of reference [8], it is believed that the failure zone was related to one individual phase, which was subjected to faults and experienced the initial asymmetrical component of the fault in transient

IV. TRANSFORMER FAULT DETECTION

A. Under Voltage Fault

When the operating voltage decreases to lower limit of voltage rating, the under voltage fault will occur. This fault can detect by voltage sensor. The rating of Maintaining the Integrity of the Specifications subjected to a large component of flux diverted from saturated region of the core alongside. During this condition, the bolt may be rapidly heated up and destroys its own insulation as well as winding insulation. When the operating voltage increases to upper limit of voltage rating, the over voltage fault will occur. This fault can also detect by voltage sensor. The rating of this sensor is Input - (0 - 300 V) and Output - (4 - 20 mA).

B. Over Voltage Fault

There may be always a chance of system over voltage due to sudden disconnection of large load. The magnitude of this voltage is higher than its normal level but frequency is same as it was in normal operating condition. Over voltage in the power system causes an increase in stress on the insulation of transformer. As we know that, $V = 4.44\Phi.f.T \Rightarrow V \propto \Phi$, increased voltage causes proportionate increase in the working flux. The increase flux is diverted from the transformer core to other steel structural parts of the transformer. An increase in transformer terminal voltage or a decrease in frequency will result in an increase in the flux.

There are three loads are connected with transformer. In the overload condition, when the third load start working there is overload fault occur and overload alarm turn on and led glows green.

In the overvoltage condition, all loads are connect with transformer and voltage level increased with its preset value the voltage sensor sense the voltage level. Voltage level will control by relay and led glow green.

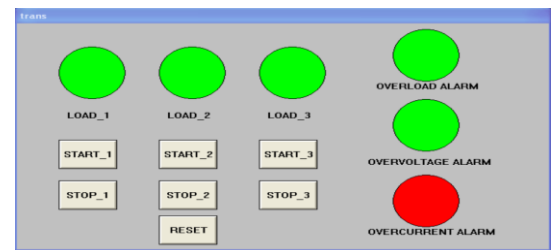

Fig. 2 The overvoltage and overload conditions

In the overvoltage condition, all loads are connect with transformer and voltage level increased with its preset value the voltage sensor sense the voltage level. Voltage level will control by relay and led glow green.

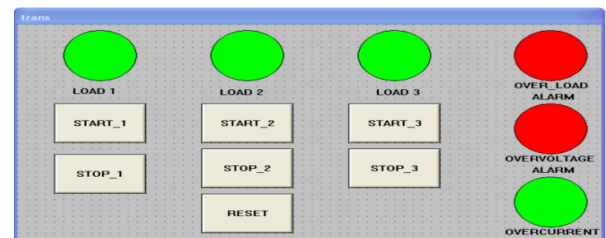

Fig 3. The overcurrent conditions

In the overcurrent condition, current level increased with its preset value current sensor sense the fault and control the current level.

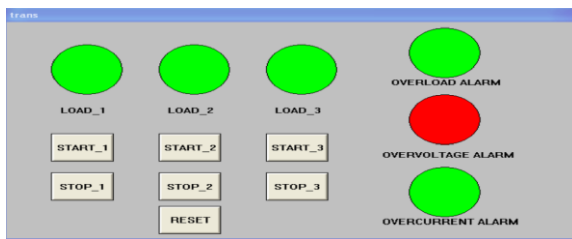

Fig. 3 The overload and overcurrent conditions

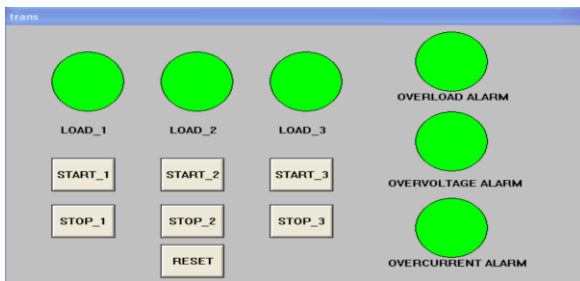

Fig. 4 All fault conditions with the all load on

V. CONCLUSION

In this paper we have presented a design of a system based on PLC that is used to monitor and control the voltage, current and temperature of a distribution transformer in both sides. The proposed PLC system which has been designed to monitor the transformer's essential parameters continuously monitors the parameters throughout its operation. When the PLC recognizes any increase or decrease in the level of voltage, current or temperature values the unit has been made shutdown in order to prevent it from further damages with the help of relays in three phase system. The system not only controls the distribution transformer in the substation by shutting it down, but also displays the values throughout the process for user's reference in SCADA system. This claims that the proposed design of the PLC system makes the distribution transformer more robust against some key power quality issues which make the voltage, current or temperature to peak. Hence the distribution is made more secure, reliable and highly efficient by means of the proposed system.

REFERENCES

- [1] Rohan Perera & Bogdan Kasztenny, "Application Considerations When Protecting Lines With Tapped and In-Line Transformers", previously presented at 2014 Texas A&M Conference for Protective Relay Engineers, © 2014 IEEE – All rights reserved. 20140210, TP6575-01.
- [2] V. Thiyagarajan & T.G. Palanivel, "An Efficient Monitoring Of Substations Using Microcontroller Based Monitoring System", IJRRAS 4 (1), July 2010.
- [3] Anurudh Kumar, Ashish Raj, Abhishek Kumar, Sikandar Prasad & Balwant Kumar, "Method for Monitoring of Distribution Transformer, Undergraduate Academic Research Journal (UARJ)", ISSN: 2278 – 1129, Volume-1, Issue-3, 4 - 2012.
- [4] Ali Kazemi & Casper Labuschagne, "Protecting Power Transformers From Common Adverse Conditions", paper

presented at the Ga-Tech and the Western Protective Relay Conferences, New Berlin" in 2005.

[5] Vadirajacharya.K, Ashish Kharche, Harish Kulakarni, Vivek Landage, "Transformer Health Condition Monitoring Through GSM Technology" International Journal of Scientific & Engineering Research Volume 3, Issue 12, December-2012.

[6] Technical Research Paper, "Microcontroller based Fault Detector", International Journal of Advancements in Research & Technology, Volume 1, Issue 5, October-2012-1 ISSN 2278-7763.

[7] Mallikarjun Sarsamba, Dr. Raju Yanamshetty & Prashant Sangulagi, " The Load Monitoring and Protection on Electricity Power lines using GSM Network", International Journal of Advanced Research in Computer Science and Software Engineering, Volume 3, Issue 9, September 2013 ISSN: 2277 128X.

[8] Kipp Yule, Duane Brock, and Jim Purdy, "Accountability and Evaluation of Aggregate Effects of Through Faults on Power Transformers", Unclassified Open Source.

[9] T. S. Madhavrao, "Power System Protection n- Static Relays", TMH Publication.

BIOGRAPHIES:



Akansha Dubey has done her graduation in Electrical & Electronics Engineering from United College of Engineering and Management and she pursuing M.Tech in Electrical Engineering (Power System) from S.H.U.A.T.S. Her research aims to increase Transmission & Distribution system capacity and enhancing system reliability.



Dr. Jyoti Shrivastava has done her graduation in Electrical Engineering and her post graduation in Design of Heavy Electrical Equipments. At present she is serving as an Senior Assistant Professor in Electrical Engineering department at college of Engineering and Technology, SHIATS, Allahabad, India. She has several international and National papers to her credit. Her field of interest and research are Power system control and operation, power quality improvement and condition monitoring of heavy electrical equipments. Her research aims to increase Transmission & Distribution system capacity and enhancing system reliability.