

# Development and Analysis of a Single Row Deep Groove Ball Bearing in Industrial Conveyor Belt for a Transportation of Sugar

Vrushabh Rakhade<sup>1</sup>, Rupa Sharma<sup>1</sup>, Yamini Tupe<sup>1</sup>, Shradha Akolkar<sup>1</sup>

<sup>1</sup>Department of Mechanical Engineering, Anantrao Pawar college of engineering & Research, Parvati Pune-09  
Savitribai Phule Pune University, INDIA

**Abstract-** This paper includes Design, Static and Thermal analysis of Single row deep groove ball bearing which is used in conveyor belt system for Sugar transportation. These bearings used in shaft of Driver and driven pulleys of conveyor belt. The system works 24 hours per day. The modeling of a bearing is done in CATIA V5 software and Static and thermal analysis of a system is done in ANSYS software. The boundary Condition of a system is taken in working condition of a system. This paper consists designing of ball bearing with the help of life of revolution. Paper includes all the result of thermal and static analysis of bearing.

**Key Words:** Single Row Deep groove ball bearing, Pulleys of conveyor belt, Motor, Shaft etc.

## 1. INTRODUCTION

In a conveyor belt system for sugar transportation mostly Single row deep ball bearing is used. The bearing is a mechanical component which is used to support the pulleys of a conveyor belt system. Belt conveyor is generally transport bulk material in sugar transportation. The load on bearing is in large amount. Ball bearing consist radial load and axial load. Ball bearing gives high efficiency in high speed. Generally material for ball bearing chrome steel, stainless Steel etc. is used. Noise is also important parameter while designing of a bearing. Bearing permit the rotational motion to the shaft of driver and driven pulleys. Self-alignment of a ball bearing is used when misalignment occurs in ball bearing. To calculate the life of a bearing the loading condition of a system should be known. The spherical ball is used in single row deep groove ball bearing to maintain the point contact between inner race, outer race and ball. The balls of bearing are situated in cage of single row deep groove ball bearing. Bearing mostly needs two type of analysis. Papers include static as well as thermal analysis. Generally bearing has point and surface between the balls and cage of a bearing.

In this conveyor belt system bearing is important machine element. The conveyor belt transports the 20 ton sugar per hour. In this system bearing frequently fails because of speed of a conveyor belt system. In single row deep groove ball bearing balls is important element it transfers the load taken by shaft to the frame. The deformation of bearing is also depending on the internal heat generated by single row deep groove ball bearing. A bearing also gives the lubrication to the conveyor belt system. The radius of spherical ball is maintained by the curvature of the grooves in the races. Conveyor belt consist the large amount of radial load. Single row deep groove ball bearing consist high radial load carrying capacity and thrust load carrying capacity. As the number of spherical ball increase in the assembly of a single row deep groove ball bearing radial capacity is increases but thrust load carrying capacity is decreases.

If the number of ball increases in a bearing for conveyor belt application, then the efficiency of the system can be increase. Thermal stresses of a single row deep groove ball bearing can be reduced by applying proper lubrication to the shaft of driver and driven pulleys of a conveyor system. The conveyor belt pulleys have a 1440RPM motor which actually gives 1100 RPM speed to the pulleys of a conveyor belt. It also has a worm and worm wheel gear box with reduction ratio of 46. The speed of a system is depending on diameter of pulley. The single row deep groove ball bearing is attached at the shaft. The single row deep groove ball bearing are have poor thrust load carrying capacity as compare to another types of bearing. The balls are situated between the cages of bearing.

The friction of balls it is also important parameter for designing single row deep groove ball bearing. For the Designing of a ball bearing it required the entire load on a system. The belt speed of a conveyor belt is required. From the working hours of a system bearing life can be calculated. Life of bearing is depends on revolution of a shaft. Thermal consideration of a bearing is taken in at time of working condition of a conveyor belt system. It is also important factor of a bearing failure

## 2. CAD MODELING

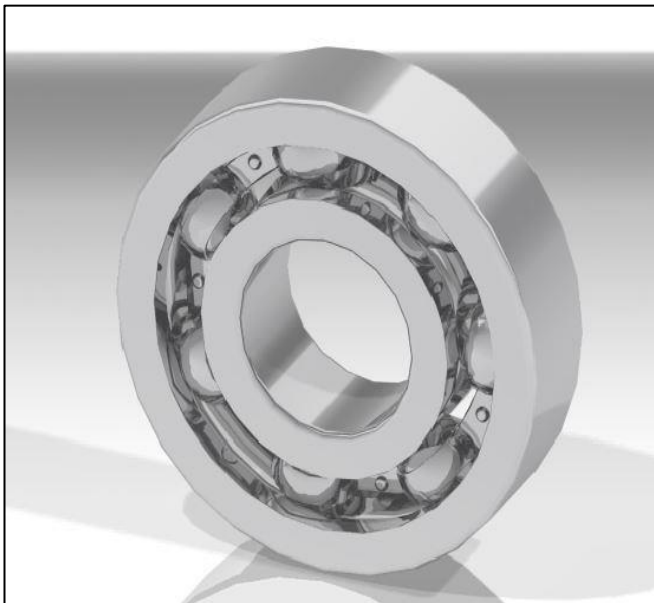

Fig no-1 Cad Modeling

## 3. VIEWS OF BEARING

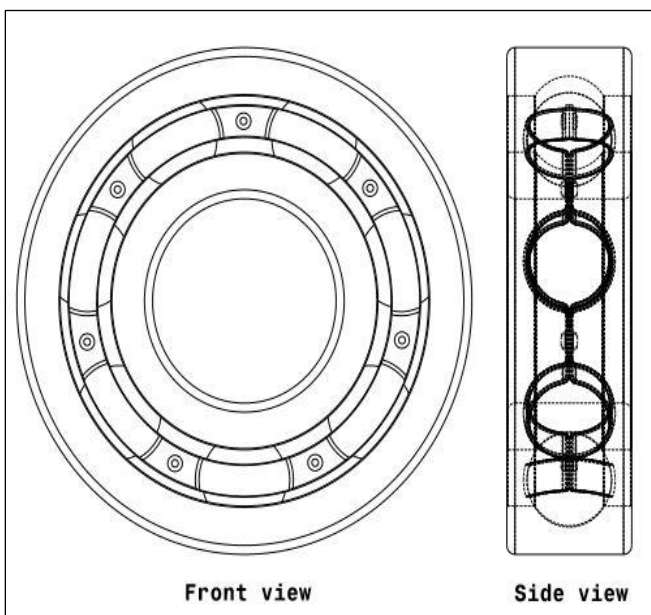

Fig 2- Views of bearing

## 4. Input Data

Selected bearing is 6405

Inner Diameter=25mm

Outer Diameter=80mm

Width= 21mm

Static Load=35800N

Dynamic Load =19600N

Belt tension  $T_{ft}=2323.2N$

$T_{fs}=918.6N$

Diameter of pulley=200mm

Speed of motor=1440rpm

## 5. Calculations

$$(1) \text{ Belt Speed (v)} = \pi D N / 60 \dots\dots\dots(1) \quad (\text{m/s})$$

$$= 14.66 \text{ m/s}$$

$$(2) \text{ Reduction Ratio (G)}$$

$$G = N/n$$

$$= 47$$

$$(2) \text{ Power Transmitted by Belt (P)}$$

$$P = 2\pi N T / 60$$

$$= 0.9624 \text{ Hp}$$

$$(3) \text{ Total Radial Load (T)}$$

$$T = \frac{T_{ft} + T_{fs}}{2}$$

$$= 1620.9N$$

$$(4) \text{ Equivalent Dynamic Load (E)}$$

$$E = (X \times V \times T + Y \cdot F) \times K_a$$

$$= 23762.3N$$

$$(5) \text{ Life of bearing}$$

$$L_{10} = \frac{60 \times N \times L_{10h}}{10^6}$$

$$= 169.2 \text{ million/revolution}$$

$$(6) \text{ Calculate Dynamic Load Capacity}$$

$$C = T(L_{10})^{1/3}$$

$$= 1620.9 \times (169.2)^{1/3}$$

$$= 8965.12N$$

Following design is safe,

$$19600 > 8965.12$$

Calculated dynamic load Capacity must be less than of Basic dynamic capacity.

## 6. ANALYSIS OF BEARING

### 6.1 Meshed Model

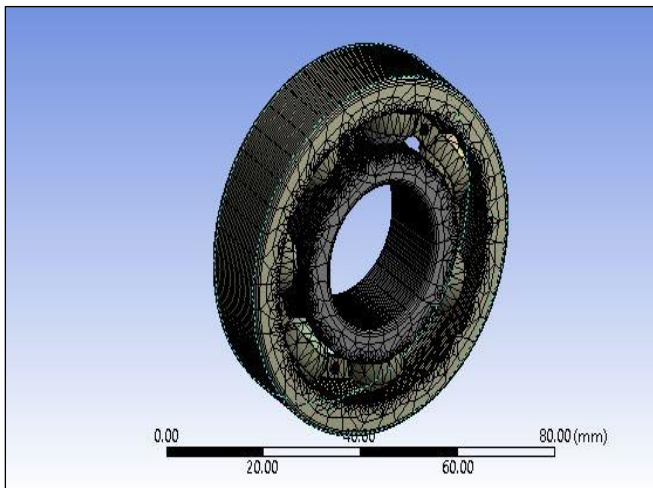

Fig no 3-Meshed model

## 7. STATIC ANALYSIS

### 7.1 Total Deformation

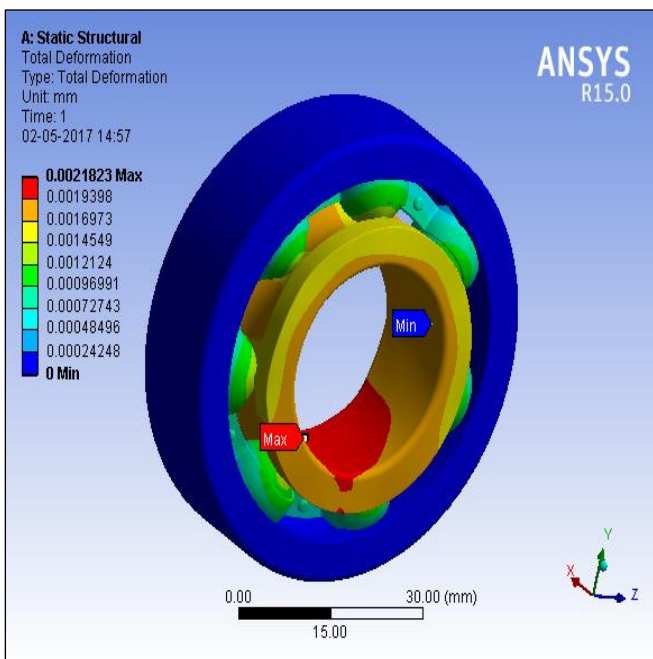

Fig no 4-Total Deformation

### 7.2 Equivalent (Von -mises) Stress

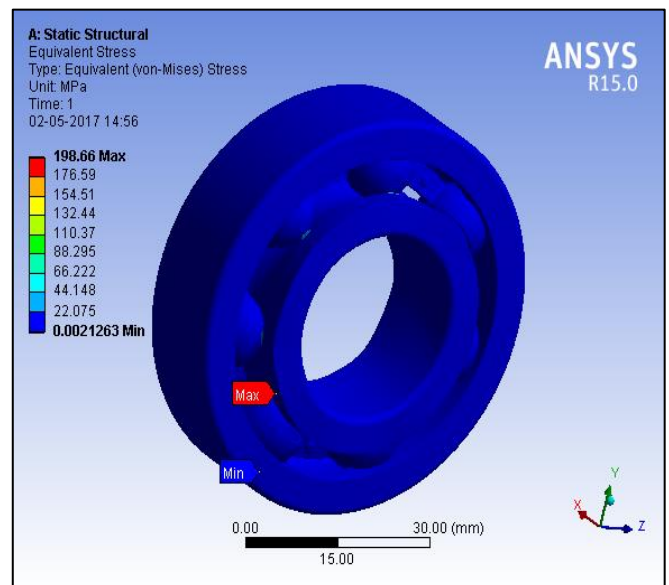

Fig no 5-Equivalent (Von -mises) Stress

### 7.3 Life of Bearing

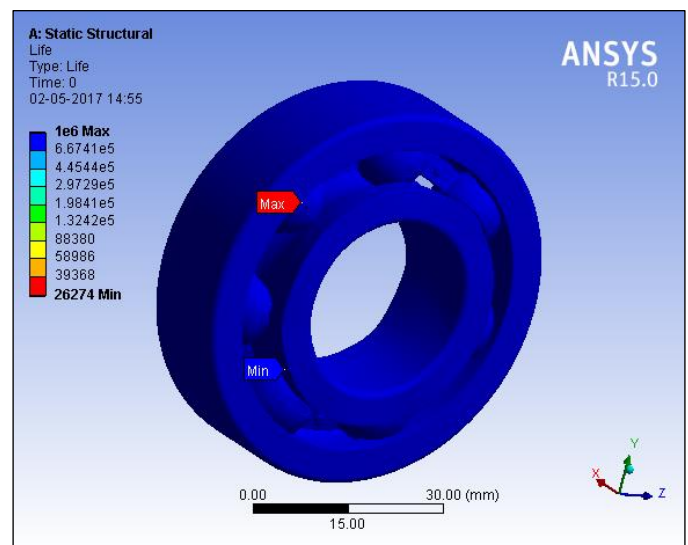

Fig no 6- Life of Bearing

## 8. THERMAL ANALYSIS

### 8.1 Temperature

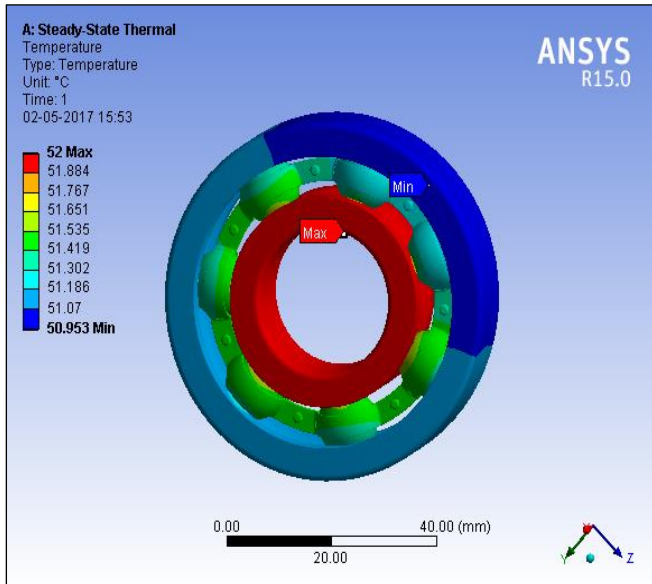

Fig no 7- Temperature

### 8.2 Heat Flux

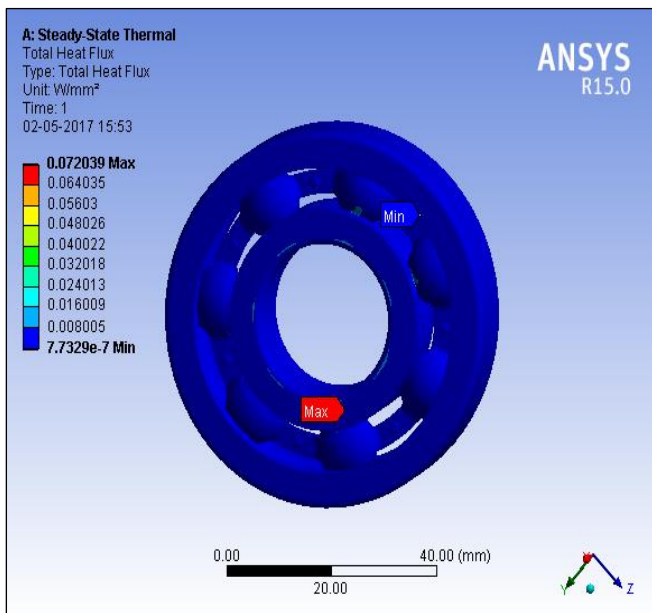

Fig no 8- Heat Flux

## 9. CONCLUSION

Paper includes Steady state structural and steady state thermal analysis of a conveyor belt system for a transportation of sugar. As number ball increases radial load bearing capacity can be increases. Life of single row deep groove ball bearing is calculated by numerical method as well as analytical method.

## 10. REFERENCE

- [1] Viramgama Parth D "Analysis of Single Row Deep Groove Ball Bearing", May - 2014
- [2] M. Chandra Sekhar Reddy "THERMAL STRESS ANALYSIS OF A BALL BEARING BY FINITE ELEMENT METHOD" IAEME Publication
- [3] Milan zeljković, aleksandar živković, ljubomir borojev "BALL BEARINGS STATIC BEHAVIOR AND LIFETIME"
- [4] Ms. Rohini n.sangolkar and Mr. Vidhyadhar p. Kishirsagar "Failure analysis and Prospect analysis of a industrial conveyor belt-A Review" IJSRD Vol.3 ISSUE 02, 2015