

# A Research paper on Design and Analysis of Shaftless Steam Turbine

Bhavin Bhanushali<sup>1</sup>, Prince Vishwakarma<sup>2</sup>

<sup>1</sup>Undergraduate, Alpha College of Eng. and Tech., Gandhinagar-382721, Gujarat, India

<sup>2</sup>Assistance Professor, Dept. of Mechanical Eng., Alpha College of Eng. and Tech., Gujarat, India

\*\*\*

**Abstract** - Shaftless Steam Turbine consists of a Double row spherical roller bearing, the outer race of which is provided with a tight fit ring. The periphery of the ring forms base for mounting rotor blades. The inner race is fixed by a suitable arrangement. A hollow frustum tapered cone whose larger diameter is fastened to outer race ring and smaller consists of a flange which couples with generator shaft. The cone transmits the rotational motion of the rotor. A nozzle provides sufficient enthalpy drop to the turbine.

**Key Words:** Double row Spherical Roller Bearing, Hollow frustum tapered cone, nozzle, Rotor Blades, Hood.

## 1. INTRODUCTION

Increasing fuel prices and their extinction, forces the engineers for developing new technologies for conservation of fuels for future. New ideas aim to reduced emissions, Low operating and maintenance costs, and opportunity for ancillary industries. This research paper introduces the next generation in the history of steam turbines aiming to "Low pressure power generation", and can be commercially implemented. Thus, an approach towards a Shaftless Steam Turbine is visioned for assisting commercial Power generation.

### 1.1 The Steam Turbine

Steam turbine is a major toy in power generation. Compared to other sources of Energy conversions they give better efficiency. Extensive researches are being carried out for improving efficiencies of conventional Steam Turbines Design. The Power Plants using Steam Turbines as a prime mover are based on Rankine Cycle, and Gas Turbines are based on Brayton Cycle.

The Superheated steam generated in a boiler is pressurized in a steam drum and after reducing its enthalpy by a nozzle, is supplied to Steam Turbine. The nozzle directs the steam, thus steam impinges on the rotor blades with sonic velocities. The steam turbine expands the steam and extracts energy contained in it and energy conversion takes place. The rotor rotates due to force exerted by a jet of steam and this rotational motion is supplied to generator/alternator coupled with turbine rotor.

The Alternator uses Electromagnetic Induction principle and generates a constant frequency of electric current which

is also used to boost the Alternator. The equipment used for boosting alternator is known as Exciter.

## 2. LITERATURE REVIEW

**Performance Improvement of Mechanical Drive Steam Turbines (By Hisakuni Takenaga and Kazuso Katayama, Mitsubishi Heavy Industries Ltd.) Proceedings of 11th Symposium [1]:** This literature can be considered as an excellent literature because it improves the performance of turbines. It is presented by industrial experts from Mitsubishi Heavy industries. This literature explains that how to improve performance by decrease in exhaust losses, improvement of nozzle and blade profile, reduction of leakage losses, reduction of moisture loss, and modification of existing turbines. The literature provides proper theoretical and graphical parameters which are used for the performance improvement. It also shows the test facility of real situation turbine after modifications. An improved design of nozzle and changes in the angles of blades has been carried out. The droplets or moisture present in the steam cause corrosion of turbine parts, a drain catcher mechanism has been employed to reduce the moisture content and the droplets can be recovered. The turbine tested after modification under test conditions shows a performance curve which is parallel to the expected curve. The decrease in the exhaust losses are done by enlarging the plenum chamber in the last stages of the blades. The flow pattern of the steam over the blades is improved by changing the profile of the blade. This paper has confirmed the changes in the effectiveness and efficiency in the turbine under test conditions and is implemented worldwide for better energy conservation.

**The Royal Academy of Engineering "Forces on Large Steam Turbine Blades" [2]:** A Turbine shaft rotates at high rotational speeds of 3000-4000 rpm. At such high speeds large centrifugal forces act at the blade root. Such high centrifugal forces can break the blade and can costs Emillions to repair, Shut down of power plants, and consequently large generation cut off of electricity. Thus, after understanding such serious situations, this research paper is very useful. The research on turbine blades discloses that large centrifugal stresses can cause heavy damage to the organization. In this paper such stresses has been calculated and permissible or safe stress limit of the stress can be found out. For specific parameters of turbine and its blade materials the safe stress are calculated and the

design of blade is preceded. Thus by evaluating the stress acting at the blade root by a simulation software and designing an evenly distributed stress blades large money can be saved.

**Charles Algernon Parsons "The Steam Turbine" (1911) [3]:**

The Steam Turbine is a book written by Sir Charles Parson who is known as the father of Turbine. He is known for his modern 50% multi stage reaction turbine, which gives the information about the effective and efficient use of the enthalpy in the soul of steam. This mechanism has a great control of turbine speed limitations and can give constant speed range. This in turn gives constant frequency generation of electricity. Several Steam Turbine driven vessels including the famous ship "Titanic" was powered by Parsons Principle. His invention of reaction turbine also became the principle for power generation and can give great efficiency if properly designed. By using his reaction principle combined impulse-reaction turbine can be designed for less floor space area. The compounding mechanism can be employed on the basis of such inventions; this consequently gives proper steam flow and distribution in the chamber. Thus by using his principle the whole world is generating electricity effectively and efficiently without any difficulties, and steam can also be extracted for further usage in co-generation power plants for process purpose.

**General Physics Corporation, Elkridge, Maryland (© 2003) [4]:**

General information on Steam Turbine has been reviewed. Different parts of the turbine, turbine support systems, simulation of blades, how steam reacts when it impinges on blades, such important parameters were referred. Proper incidence angle have to be chosen for efficient utilization of steam energy. Moisture content in the steam can cause corrosion of blades thus imbalance results in vibration. Protective setpoints are designed to ensure that excessive moisture called carryover does not occur in the main turbine during normal operation.

**2. CONVENTIONAL STEAM TURBINE ROTORS**

In Conventional Turbine design the shaft and the disc are forged as one piece. The periphery of the disc is grooved for mounting the blades, Fir tree mounting of blades are widely used for high blade root stress operations. The disc is tapered from the center for proper stress distribution.

Both the ends of the shaft are provided with a hydrodynamic forced lubricated Journal Bearing (refer Fig-1). Fig-2 shows a still from a Power Plant using conventional steam turbine rotor.



**Fig -1: Turbine front end journal bearing**



**Fig -2: Conventional Steam Turbine Rotor**

The shaft used in this design is of several tonnes and contains unbalances masses which when operated at critical speed; the shaft tends to whirl and rotates eccentrically inside the casing. As there is minor clearance between the top of the blades and casing, the blades rub with casing. Consequently, blades are damaged and due to friction the speed of the turbine also reduces. Thus, high mass flow rate and high pressure steam is required to overcome such situation.

The vibrations are mainly caused due to unbalances masses present in the rotor disc. For maintenance, the rotor is tested under vacuum tunnel and balance masses are added or unbalance masses are removed. The process is very costly and requires latest technology equipment which is rarely available. High weight of rotor requires higher steam pressure and more burning of fuel.

### 3. THE SHAFTLESS STEAM TURBINE

As in conventional Steam Turbines the rotor blades are attached on periphery of the disc. This arrangement results in heavy weight of the rotor, Unbalance of the shaft and rotor, play in the journal bearing, vibrations, poor cold starting and peak load performance, reduction in efficiency, high on maintenance costs.

The Shaftless Steam Turbine aims for low pressure power generation. The shaft is replaced by a double row spherical roller bearing. Below Fig-3 and Fig-4 shows CAD model and experimental setup of real shaftless steam turbine.

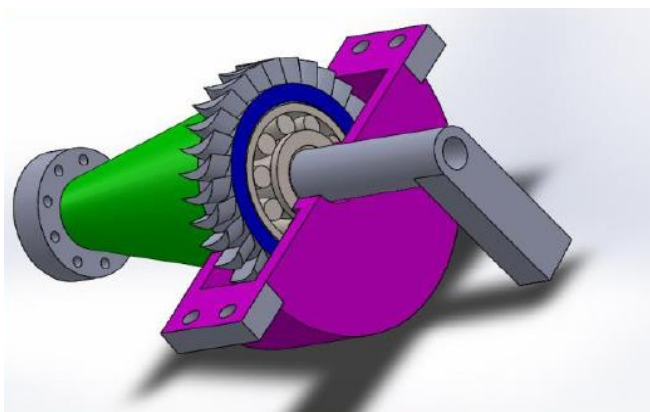

Fig -3: CAD model of Shaftless steam turbine



Fig -4: Experimental setup of Shaftless steam turbine

The Spherical roller bearing is in angular contact, thus permitting the misalignment of the hollow frustum cone. Inner race is fixed by inserting a pressed fit hollow ring fastened with the base. Below Fig-5 shows the rotor of Shaftless steam turbine,



Fig -5: Rotor of Shaftless steam turbine

### 4. DESIGNING OF SHAFTLESS STEAM TURBINE

Table -1: Design Parameters

Parameter	Value
Superheated steam temperature [5]	535° C
Enthalpy of steam at inlet of turbine	2950 kJ/kg
Spherical Roller bearing Designation	23038EW33
Make [6]	Nachi (Japan)
Bearing outer diameter	290 mm
Bearing inner diameter	190 mm
No. of blades	38
Diameter of nozzle at outlet	0.80

The Turbine is designed according to the data available from a typical Power station. These data were helpful in evaluating design of blades, selection of bearing, design of nozzle, design of hood, etc.

#### 4.1 Why Spherical Roller Bearing?

- Bear High Radial and Thrust Loads.
- Bearing Axial Width for mounting blades.
- Cater Misalignments.
- High temperature operations.
- Availability in the market.
- Economic factors.

### 4.2 Design Formulae

Table -2: Formulae

Basis	Formula
Velocity of Steam at outlet of nozzle [7]	$C_2 = \sqrt{2(h_1 - h_2) + C_1^2}$
Area available for Steam to flow	$A_f = h \times b \times m^2$
Mass flow rate of Steam	$m = \frac{h \times b \times C_2}{V_2}$
Force exerted by jet of Steam on series of blades [8]	Force = mass per second [Initial steam velocity - Final steam velocity]
Blade speed	$V_b = \frac{\pi D_m N}{60}$
Efficiency ( $\eta$ )	$\frac{\text{Work done per second}}{\text{Kinetic Energy per second}}$
DESIGN OF BEARING [9]	
Thrust component $F_a$ created due to Radial load $F_r$	$F_a = \frac{0.5 F_r}{Y}$
Equivalent Bearing Load (N)	$P = XVF_r + YF_a$
Bearing's Dynamic load carrying capacity (N)	$C = P (L_{10})^{0.3}$
Bearing's Life in million Revolutions	$L_{10} = \frac{60NL_{10h}}{10^6}$
Power Developed	Power = Radial force x Blade speed

### 4.3 CFD Analysis of Rotor Blades [10]

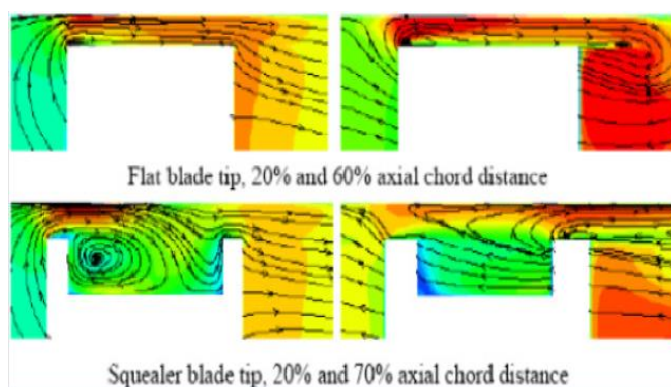

Fig -5: Analysis of Blade tip

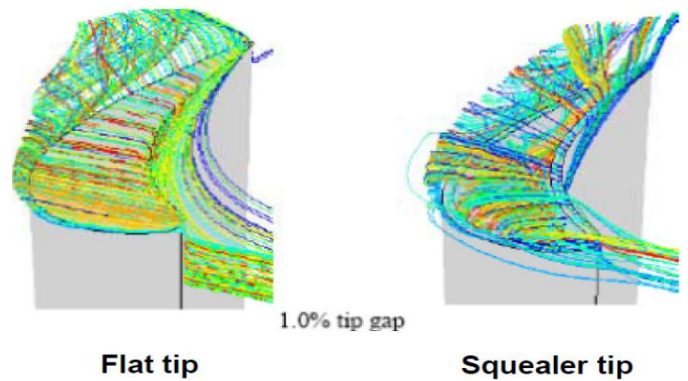

Fig -6: CFD analysis of blades

### 5. DIAGNOSING THE STEAM TURBINE

Suppose 1 Ton Steam at enthalpy 800 kcal/kg at temperature 500°C is required to generate 1MW electricity, But when steam at enthalpy 700 kcal/kg at temperature 450°C will require 2 Tons to generate 1MW of electricity. Thus we can observe from the above situation that steam consumption of steam with higher enthalpy at higher temperature and pressure will be less compared to steam which has lower enthalpy and temperature. Fig-7 represents the effect of inlet steam temperature-steam consumption.

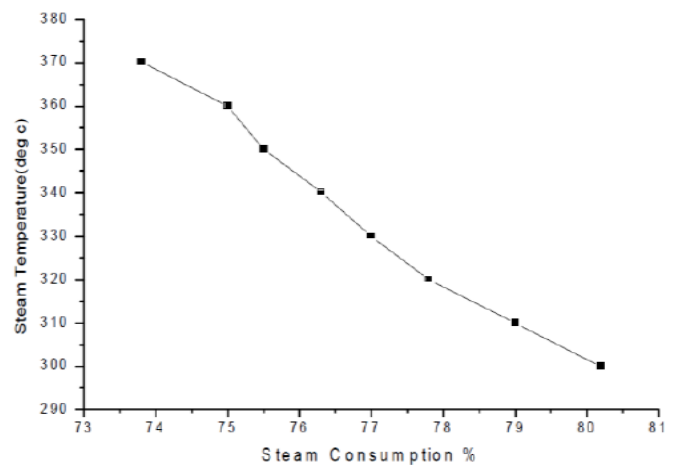

Fig -7: Effect of inlet steam temperature on steam consumption [11]

### 6. CONCLUSION

The Concept of "Shaftless Steam Turbine" will be the next future technology in the history of turbines. It will overcome the balancing and vibration problems arising due to unbalance masses distributed in conventional turbines. Easy on maintenance and cost are the versatile features of this concept. It can be digitized and controlled through a Distributed control system which approves for the safety of operators. The standard parts are easily available from ancillary industries and can be easily replaced. As shaft is eliminated, there is no requirement of any bearing to rest the

shaft. Thus this concept will prove to be a highly diversified technology and can be developed further.

## REFERENCES

- [1] H. Takenaga and K. Katayama, "Performance improvement of mechanical drive steam turbines," Proceedings of 11th Symposium.
- [2] The Royal Academy of Engineering, "Forces on large steam turbine blades".
- [3] Sir C. A Parsons "The steam turbine" (1911).
- [4] General Physics Corporation, Elkridge, Maryland, "CHAPTER -10 Steam turbines," (2003).
- [5] Amanraj, "Research paper on study of steam turbine," IJIRT vol.2 issue 6, (Nov 2015), pg. 350
- [6] NACHI (Japan), "Spherical roller bearing catalogue," Page no. 20, 21
- [7] P. K. Nag, "Power plant engineering," Tata McGraw-Hill. ISBN 978-0-07-043599-5, (2002), pg. 434
- [8] Dr. R. K. Bansal, "Fluid mechanics and hydraulic machines (revised ninth edition)," (2010), pg. 833 and 834
- [9] V. B. Bhandari, "Design of machine elements (second edition)," (2009), pg. 574,575
- [10] Prof. Q. H. Nagpurwala, "Design of steam turbines," M.S.Ramaiah School of Advanced Studies, Bengaluru, pg. 55,56
- [11] R. Singh, A. Arya and S. Pandey, "Effect of steam inlet temperature on performance of partial admission steam turbine," IJERST vol. 3 No. 4, (2014), pg. 304