

# Selection of BLDC Motor and Propeller for Autonomous Amphibious Unmanned Aerial Vehicle

Krishn Das Patel<sup>1</sup>, Dr. Jayaraman<sup>2</sup>, Satheesh C.<sup>3</sup>, Sunil Kumar Maurya<sup>4</sup>

<sup>1</sup>M.tech Student, Vel tech Dr. RR & Dr. SR University

<sup>2</sup>Professor, Dept. of Aeronautical Engg., Vel tech Dr.RR & Dr. SR University

<sup>3</sup>Senior Engineer, Ucal-Jap Systems Limited

<sup>4</sup>Trainee Engineer, Ucal-Jap Systems Limited

---

## ABSTRACT:

The AAUAV is a type of Unmanned Air Vehicle (UAV) with the capability to operate as an aerial vehicle as well as on water surface as it is the combination of two vehicles viz. a multicopter and a hovercraft. AAUAV can be used in almost, each and every, water cum aerial based missions. The aim of this paper is to represent a method for evaluating brushless DC motors (BLDC) and propeller that can be used in the multicopter or the hovercraft as per the design specification of different types of the vehicles. Selection of a BLDC motor and propeller is being done here by the comparison of the theoretical values given in the datasheet of the motors and practical thrust calculation performing on a couple of motors. The comparison shows the difference in percentage proving that the loss is always there in the practical implementation and testing of the motors. Also, the difference range is being provided.

**Keywords:** Amphibious UAV, bldc motor, multicopter, propeller,

## 1. INTRODUCTION:

The usage of Unmanned Aerial Vehicles (UAVs) has grown drastically because of their ability to operate in dangerous locations while keeping their human operators at a safe distance. UAVs are widely used in military operations nowadays because of their reliability, cost effectiveness and multi-functionality. The propulsion system as the name specifies to propel something by the application of the force. The simple meaning of propulsion is to give the motion in the forward direction. It is believed to be one of the most important subsystems of the UAV. In multicopter systems, electric propulsion is normally used and in this electric propulsion system the most important task is selection of BLDC motor and Propeller combination. During selection of the system one of the first things to consider Maximum Take-off Weight (MTOW) of the system. Because combined motor and propeller combination should be able to generate thrust twice the flying weight of Multicopter system.

## 2. METHODOLOGY

Most of these UAVs are equipped with electric motors that contribute to the simplicity of operation and significantly reduce their noise signature. The propulsion systems of these small UAVs (batteries, motor, propeller, etc.) account for as much as 60% of the vehicle weight Therefore, optimization of the propulsion systems is extremely crucial. The electric propulsion system of a typical UAV includes the following components: propeller; electric motor; energy source, wiring, plugs, and connectors [1].

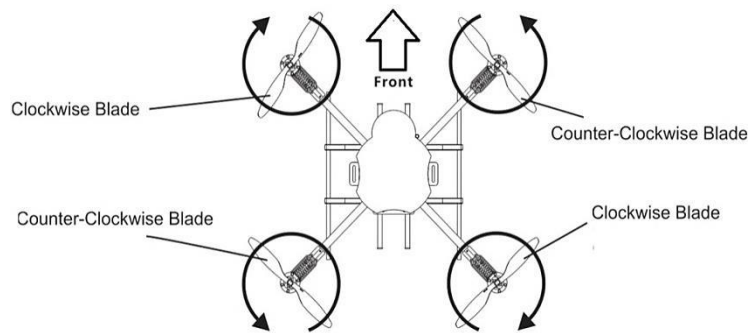

Fig.1 Schematic diagram of quad copter [6]

Brushless DC motors also termed as BLDC motors are used in Quadcopters. These motors consist of a permanent magnet which rotates around a fixed armature. They offer several advantages over brushed DC motors which include more torque per weight, reduced noise, increased reliability, longer life time and increased efficiency.

Motor calculations: The motors should be selected in such a way that it follows following thrust to weight relationship [2].

$$\begin{aligned} \text{Ratio} &= \text{Thrust} / \text{weight} = ma / mg \\ &= a / g \end{aligned}$$

Thus, vertical take-off and vertical landing (VTOL) is possible only when,  $(a/g) > 1$  or in other words, the total thrust to total weight ratio should be greater than 1 so that the quadcopter can accelerate in the upward direction [2].

$$\text{Total Thrust} = 2 * (\text{Total weight of Quadcopter})$$

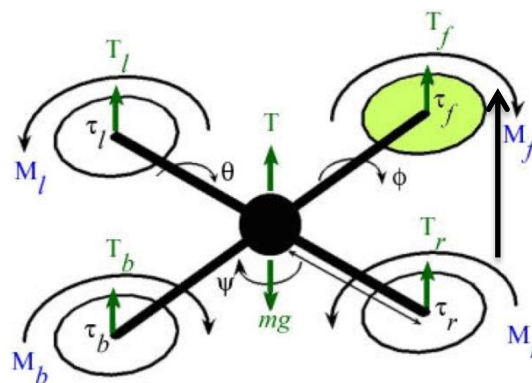

Fig.2 VTOL of quad copter [7]

The electronic speed controller is selected based on its Ampere rating. This should be greater than ampere rating of the motor [3].

$$\text{ESC rating} = (1.2 \text{ to } 1.5) \times \text{max. Ampere rating of motor}$$

Max. Current withdrawal by motors = no. of motors \* maximum current withdrawal by single motor. The discharge current of battery should be higher than the maximum current withdrawn by motors [3].

Discharge current= Capacity in ampere \* discharge rate.

Flight time for quadcopter is calculated as follows,

$$\text{Flight time} = (\text{Capacity in amperes} / \text{Current draw}) * 60$$

Motors are selected based on their Kv rating. It is calculated by the formula [4].

$$\text{RPM} = \text{Kv rating} \times \text{Voltage input}$$

### 3. SELECTION OF BLDC MOTOR AND PROPELLER:

The Propulsion system consists of Motor, Propeller, electronic Speed controller, batteries and propeller. Both the motor and propeller combination produces thrust and moves the vehicle. Quadcopter and Multicopter usually use Brushless motors as there power plants. When selecting the motor and propeller combination it is important to determine the specific Application area, because if we want to do multicopter racing and or acrobatics at that time we require Higher KV of the BLDC motor with small size of propeller, or if we want to carry a payload such as a video camera and gimbal then we need to select a Less KV of the BLDC motor with a large Propeller Size.



Fig.3. Higher KV BLDC motor with Small propeller Combination [8]



Fig.4. Less KV BLDC motor with higher propeller combination [9]

### 4. THEORETICAL CALCULATION:

Condition	Formula
Thrust	$\text{Thrust} = P * D^3 * \text{RPM}^2 * 10^{-10} \text{oz}$
ESC Rating	$\text{ESC rating} = [1.2 \text{ to } 1.5] * (\text{max. ampere rating of motor})$
RPM	$\text{Rpm} = \text{KV rating} * \text{Battery Volt input}$
Flight Time	$\text{Capacity in amperes} / \text{Current draw} * 60$

Table 1. Theoretical Calculation formula

### 5. EXPERIMENTAL SET UP:

Thrust rigs, test and for comparing the static thrust produced by the BLDC motor as well as selection of combination of the Propeller. The fairly simple construction contains a weighing machine, a Tachometer and a Wattmeter to measure the Thrust, RPM and the Current Drawn respectively, and provide comprehensive, accurate and efficient data coming from the BLDC Motor including the Propeller and Electronic Speed Control (ESC).

#### 5.1 MAJOR COMPONENT OF TEST SETUP:

- Tachometer
- Wattmeter
- Weighing Machine
- BLDC motor
- ESC
- Propeller
- Lipo Battery
- Transmitter & Receiver



Fig.5 Experimental test setup

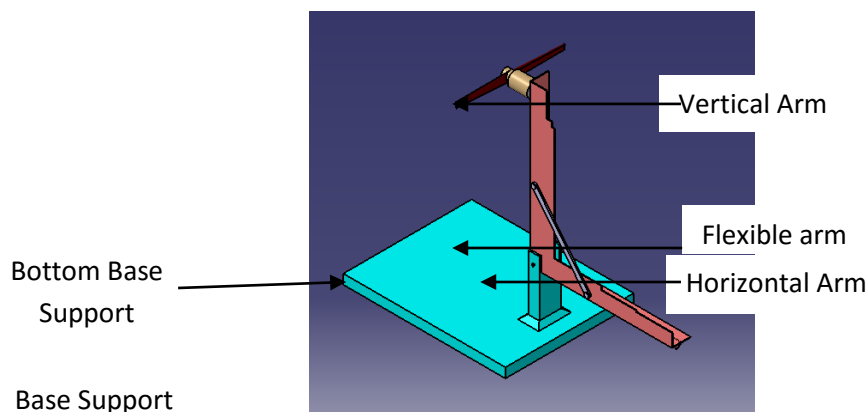

Fig .6 Isometric view of test setup

## 6. COMPARING THEORETICAL AND EXPERIMENTAL RESULT OF MOTOR AND PROPELLER:

### 6.1 Theoretical Result:

Theoretical Result		
Prop: 9 x6		Motor: 1120KV
Sr. No.	Rpm	Thrust( Kg)
1	2000	0.04
2	4000	0.16
3	6000	0.3665
4	8000	0.6498
5	10000	1.01
6	12000	1.4641

Table No.1 Theoretical Result

### 6.2 Experimental Result:

Experimental Result		
Prop: 9 x6		Motor: 1120KV
Sr. No.	Rpm	Thrust( Kg)
1	2000	0.024
2	4000	0.1489
3	6000	0.31
4	8000	0.56
5	10000	0.92
6	12000	1.288

Table No.2 Experimental Result

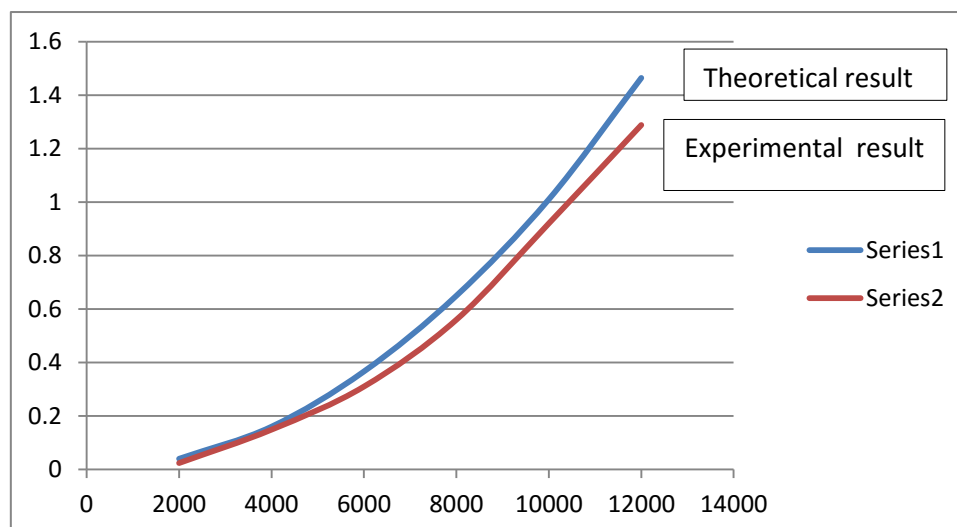

Graph:1 Comparing Theoretical and Experimental result

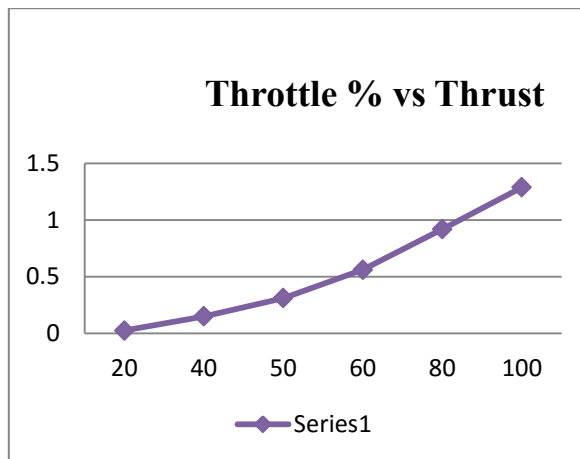

Graph: 2 Experimental result

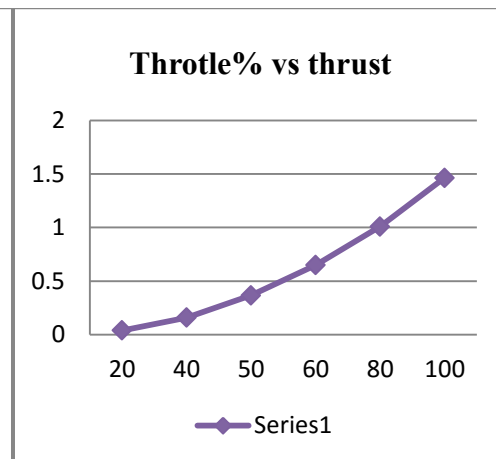

Graph: 3 Theoretical result

**CONCLUSION:**

The testing for the precise selection of the electric propulsion system, viz. bldc motors and propellers is done as per the set up. After taking theoretical value as well as performing experimental calculation for thrust and compared both the results. The results show that we are getting 12% less thrust in experimental analysis. The result comparison is shown in the above. So, based on the results, it can concluded that for any selection of the propulsion system, this loss of 12% has to be included in calculation and at the time of the selection. Considering this loss before selecting the propulsion system will lead to the usage of the precise component according to the requirement of the vehicles.

**REFERENCE:**

[1] Ohad Gur and Aviv Rosent “Optimizing Electric Propulsion Systems for Unmanned Aerial Vehicles” 2009.

[2] Prof.A.V.Javir, Ketan Pawar, Santosh Dhudum, Nitin Patale, Sushant Patils Design, Analysis and Fabrication of Quadcopter JIAATS March 2015

[3] Anand SS, and Mathiyazaghan R “Design and Fabrication of Voice Controlled Unmanned Aerial Vehicle”2016

[4] Akshay Balachandran1, Akshay Shah, Dr Jayaramulu Challa “Propulsion Selection and Analysis for Unmanned Aerial Vehicles for SAE Aero Design Series” IJES 2014

[5] Pankaj Singh ,Bhavik Gupta, Ankit Patel, Anurag Kumar, Mohit Ujjwal “ Autonomous Intelligence Surveillance Quad Copter” IJERMT march 2015

[6] <http://www.unmannedtech.co.uk>

[7] <https://www.intechopen.com>

[8] <http://learnrobotix.com/uavs/quadcopter-basics/quadcopters-multirotors-motors-propellers-basics.html>

[9] <http://dronehitech.com/en/t-motor-f40ii-review/>