

Induction Motor Control by Stator Voltage Control Method using PLC: A Review

Priyanka D. Dukare¹, P.P. Jagtap²,

¹Student, Department of Electrical Engineering, GHRCE, Nagpur, India

²Assoc. Professor, Department of Electrical Engineering, GHRCE, Nagpur, India

-----***-----

Abstract—The application of programmable logic controller (PLC) for controlling the operation of induction motor such as forward and reverse direction and speed is proposed in this paper. To run the motor on desired speed a program will be prepared in the PLC which will provide the gating signal to the driver circuit which will control the motor speed and its position according to the command given.

Key words—PLC, induction motor, FBD, I/O modules.

1. INTRODUCTION

Today there are number of manufacturing and process industries where the motors and electrical drives plays important role in carrying out different process operations such as in textile industries, food processing industries, glass industries, cement industries etc. The most commonly used motor in industries is an induction motor because of its simplicity and ruggedness. Hence controlling and co-ordinating the motor operation with other process elements is important in industrial control system. Here the PLC (programmable Logic Controller) plays an important role due to its powerful functions, resistant to strong interferences, high reliability and ease of operation. PLC has an advantage of high control speed and high flexibility and can efficiently work in harsh industrial environments that contain relatively high levels of electromagnetic interferences (EMI), contaminations and vibrations. It efficiently involves the capability of motion control.

Today, the need of automation in the industrial processes has caused mass production in reduced time frame with less human error and increased safety which has led to the increasing use of PLC based automation system because of the benefits as stated above. Also the variable speed application of an induction motor with the help of AC drives by using controller like PLC improves control of a process, saves energy utilization, decrease wear and tear on the machinery and additionally it improves the power factor.

Few papers studies have shown [1] a three phase induction motor drives a dc generator supplying variable load. The IM is fed by a rectifier and PWM inverter which is controlled by the PLC based controller. A closed loop control system for constant speed operation is developed with speed feedback and load current feedback. The operation is also tested for open loop condition by inactivating the PLC. The IGBT based inverter is used. A tachogenerator is used for speed sensing. The system is tested for varying load conditions and trip situations. [2]A multi drive system and SCADA is implemented for monitoring the position, speed and torque control. Communication between the field devices and the PLC has been achieved through the Profibus-DP protocol data bus. The induction motor is fed with a Vector Control Drive. And the servo motor is fed with PWM based ac drive. The performance is verified under the no-load and load condition of both the motors. [3]A PLC based control system for the speed, position and torque control of the PMSM is designed and its interface with the SCADA system for real time monitoring and control is implemented. The development of HMI (Human Machine interface) provides real time touch to the virtual process. RS-232 serial communication interface is used to connect drives with the PLC which uses Profibus-DP protocol to communicate with PLC and Modbus protocol to communicate with operator console. The system has been tested for different position and speeds of the motor. [4] The operation of the IM is controlled with the PLC by using PID control technique. A linear V/f characteristic is used to control the motor. For remote monitoring and control an OPC server is used in client/server mode of communication. OPC is a software interface standard that allows Windows program to communicate with industrial hardware devices. The motor speed response and network time delay was monitored. [5]A Programmable Logic Controller is used for controlling the speed of IM and ram position of Hydraulic Press machine. The IM was fed with the VFD. The use of PLC has eliminated the need of ADC card and Programmable Integrated Circuit (PIC) which provided them with better efficiency in its operational cycle. The high and low voltage protection is provided for HP machine during starting and under operating conditions as the machine is fed with a VFD. The

PLC program is developed to sense the ram movement at each stage which provide high rate of efficiency.

2. PLC BASED CONTROL SYSTE

The programmable logic controller mainly consists of I/O modules, memory, processing unit and programming device which is a personal computer. The input and output modules are divided as analog input and output module and discrete input and output module which provide facility to interface the analog as well as discrete input and output devices to the PLC.

The PLC works in three steps i.e. input scan, program scan and output scan. Before turning on any output device the processor has to scan entire program that stored in its user memory. In input scan it reads the input terminal and updates the input status table accordingly. During program scan the data in the input table is applied to user program, the program is executed and output table is updated accordingly. At output scan the data associate with the output table is transferred to the output terminal.

With its ability to communicate effectively via the industrial communication network like Ethernet, MODBUS, PROFIBUS, the control becomes more precise and makes the real time monitoring of the process parameters possible. PLC being a universal controller can carry out various operations required for process control by programming it in desired way. The operation could be from starting and stopping the motor to the logical and mathematical computation.

3. PROPOSED SYSTEM

The block diagram of the system to be prepared for the proposed work is shown in Fig. 1. A three phase Induction motor is used to test the operations such as running the motor in forward or reverse direction and to run it on the desired speed command given by the user. An SCR based driver circuit is used to run the motor on desired speed. The circuit also comprises of an opto-isolator which separate the PLC from the power circuit to protect it from other high level signals. To run the motor on set speed the gating signal to the SCR is controlled with the help of the program prepared in the PLC. The programming language used here is Function Block Diagram (FBD). In this system instead of using PWM method of speed control, a stator voltage control method is employed. A circuit with toggle switch is also prepared to switch the forward or reverse direction.

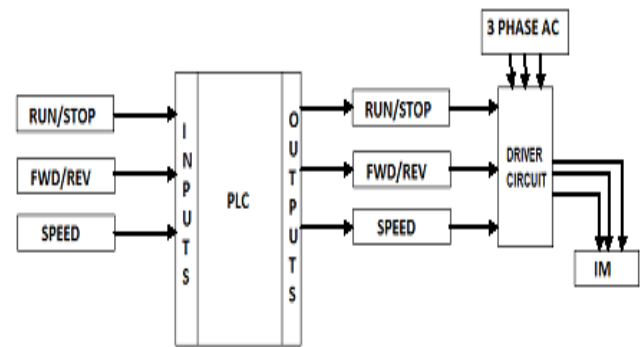

Fig- 1: Block diagram of the proposed system.

3.1 POWER CIRCUIT OF THE SCR

The power circuit for the SCR based driver is shown in the Fig. 2. A center tap transformer is used to rectify the AC supply and convert it into the DC. This DC supply is given to the dual OPAM which works as a comparator. The dual OPAM generates swatooth waveform due to the different timing of the charging and discharging of the capacitor is given to the pulse transformer which powers the SCR of the driver circuit.

An LM555 timer is used to generate the triangular waveform. Also a NAND gate is used to compare the two signals i.e. the swatooth waveform and triangular waveform. The output of the NAND gate

3.2 FORWARD AND REVERSE DIRECTION CONTROL

To run the motor in opposite direction all we need to do is to interchange any two of the supply lines from three phase lines. If we suppose that the three phases of the applied voltage be R-Y-B, and we interchange any two phases such as Y and B, the sequence will become R-B-Y and the motor will start to run in opposite direction.

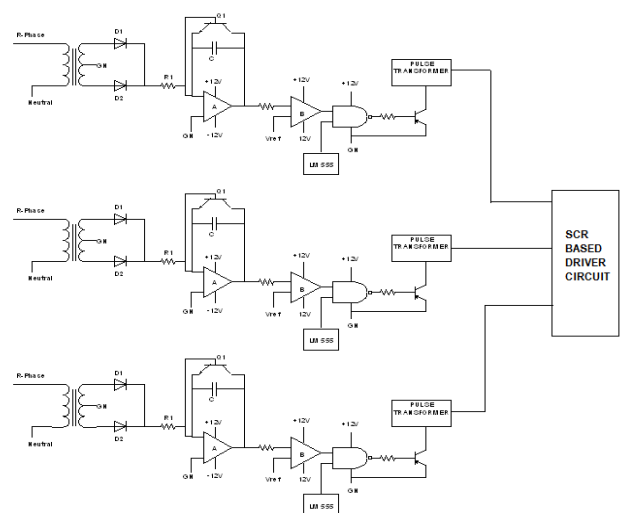

Fig- 2: Power circuit for the driver.

Here to achieve two SPDT relays are connected to Y and B phases out of the three phases as shown in fig. 3 and a circuit is designed to rotate the motor in the direction as per the command given by the user.

3.3 CONTROL SYSTEM

The control system mainly consists of PLC as controller. A program for controlling the forward and reverse operation and to run the motor on desired set speed is designed by using FBD.

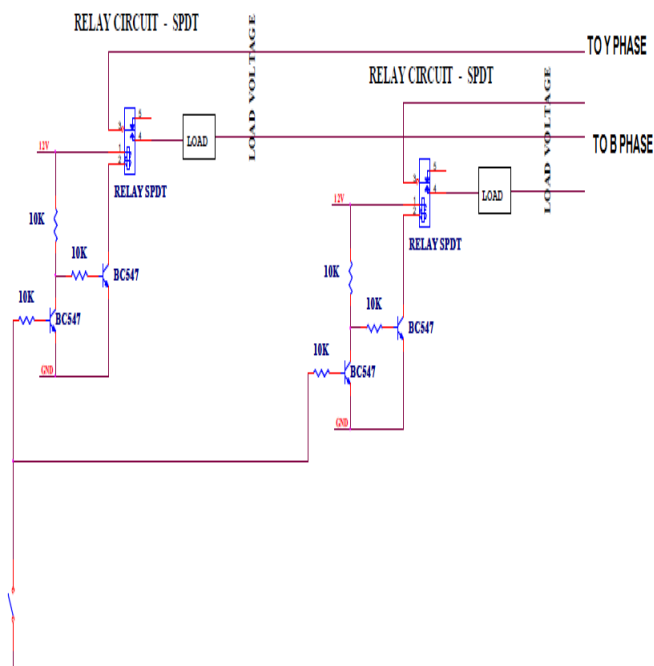

Fig-3: Circuit for forward and reverse direction

Here the control signal from the PLC is provided to the gates of the SCR. A program will be developed to run the motor on set speed given according to which the PLC will generate the output signal. As the output signal will be in discrete form a digital to analog controller is used to convert this discrete signal in the analog form. This analog output signal is used as a reference voltage signal to the comparator in the dual operational amplifier shown in fig. 2.

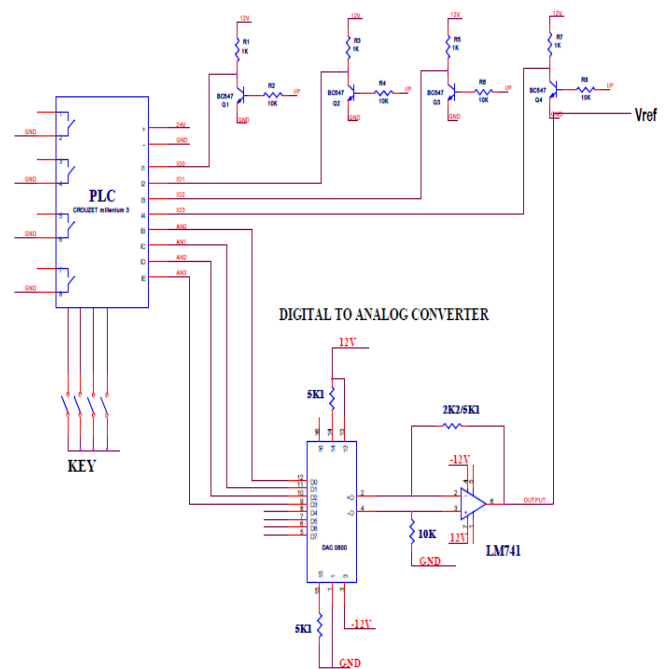

Fig-4: Control circuit

In this, instead of using PWM control method, a stator voltage control method is used. The program is also developed to protect the motor from overvoltage and overcurrent. The controller will first scan the input table for any input command given to the controller. Then according to the input command given it will execute the program called program scan and run the motor as per the command given.

The speed sensor and current sensor is attached to the input module of the PLC while the motor being output device attached to the output module of the PLC. A proximity sensor will provide the indication of the actual running speed of the motor and we will be able to monitor if the motor is running on desired speed or not.

4. CONCLUSION:

In this proposed system the PLC will efficiently run the motor in both the directions at the set speed given by the user. And when the speed command will be change the motor will reach to the new speed within a very less time span. PLC will control the entire operation very smoothly.

5. REFERENCES

- [1] Maria G. Ioannides, "Design and implementation of PLC-based monitoring control system for induction motor," IEEE Trans. On energy conversion, Vol. 19, No. 3, September 2004.
- [2] Mini Sreejeth, Parmod Kumar and Madhusudan Singh, "Development of supervisory control for distributed drives system,"

- [3] Mini Sreejeeth, Madhusudan Singh, Parmod Kumar, Prakhar Varshney and Priyanka Sachdeva, "Implementation of supervisory control system for PMSM drive,"
- [4] Maria G. Ioannides, "Design and implementation of PLC-based monitoring control system for induction motor," IEEE Trans. On energy conversion, Vol. 19, No. 3, September 2004.
- [5] Jasmin Velagic, Admir Kaknjo, Nedim Osmic and Tarik Dzannanovic, "Network based control and supervision of induction motor using OPC server and PLC," 53rd International Symposium ELMAR-2011, 14-16 September 2011, Zadar, Croatia.
- [6] D. Sowmiya, "Monitoring and control of a PLC based VFD fed three phase induction motor for powder compacting press machine," Proceedings of International Conference on Intelligent Systems and Control (ISCO 2013).
- [7] Siemens Ladder Logic (LAD) for S7-300 programming manual.
- [8] Siemens TIA Portal V11-Exercise manual.