

Study of Various Interleaved Boost Converter Controlling Techniques

Mr. Sandip Apte¹, Mr.Ashfaque Khan²

¹Asst.Professor DMIETR Wardha

²Asst.Professor Bhopal

Abstract— Renewable energy importance increases all over the world. Conversion of power from one level to another level achieved by using power switching devices. The performance of the converters mostly depends on its switching process. For maintaining the voltage at output constant irrespective of variations in DC input voltage and the load current, a control system must be required for the converter. This paper gives reviews of various control techniques for DC-DC Interleaved Boost Converter for power level conversion. Various control schemes, including linear and nonlinear control. In addition, various control techniques are compared in terms of their respective advantages and disadvantages.

Keywords—Boost Converter, Buck Converter, DC-DC Interleaved Boost converter(IBC), PID controller, Sliding Mode Control(SMC), Wind energy conversion system(WECS).

I. INTRODUCTION

Importance of renewable energy is increasing worldwide. Conventional fossil fuel has a limited reserve capacity, high price and environmental concerns. Due to this reason renewable energy is an alternative source for conventional energy. Overall the world, exploration and research community is discovering all opportunities for the efficient energy conversion from freely available generous renewable energy sources [1]. Most of the popular renewable energy sources wind energy conversion system (WECS) has gain more interest due to its no carbon emission during operation and less space requirement [1]. From a fast few decades Wind energy conversion system (WECS) has been upgraded from the minimum tens of kilo watts to numerous megawatts. Overall the world investment in wind energy conversion system (WECS) is going to be expanded [2]. Power electronics deals with variety of converters that are used not only for signal level but more effectively for power level. The performance of the converters mostly depends on its switching process. For maintaining the output voltage constant irrespective of variations in DC source voltage V_{in} and the load current required a control system for the converter [3]. A suitable DC-DC converter is proposed for extremely efficient renewable energy systems. Interleaved Boost Converter applied for renewable energy applications. The advantages of interleaved boost converter are low input current ripple, faster

transient response, and high efficiency, improved reliability and decreased electromagnetic emission. DC-DC Boost Converters can be improved as better components are developed. This encourages investigation in the areas of controllers for example to obtain high performance control of a system for this a good model of the system is required [3]. This paper focus on the different control techniques, including linear and nonlinear control, such as current mode control, PID control and sliding mode control (SMC), model predictive control, fuzzy control, hybrid control, for DC-DC boost converters have been studied [4]. Model predictive control (MPC) and fuzzy controllers are nonlinear controllers. These controllers are effective, most are complex. These controllers are difficult and expensive for practical application [4]. Now a day's current-mode scheme and linear control methods are most commonly used for controlling DC-DC boost converter but designing of current mode controller is not easy and linear control effects are limited [4].

II. CONVERTERS TOPOLOGY

A) DC - DC BOOST CONVERTER

A boost converter also known as step-up converter, it steps up the input DC voltage and gives high DC voltage at the output. Boost converter mainly consist of a switching device like transistor, diode and one element is for energy storage. Ripple present in the output voltage reduce by connecting capacitor at the output, many of the times inductor are also connected [5].

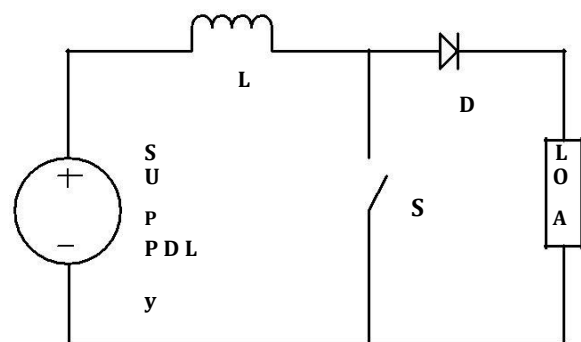

Fig.1. Boost Converter

Boost converter operates mostly of two different conditions:

Switch S close and as a resulting in increase of inductor current during the ON period

When Switch is open, inductor current flow through the flyback diode „D“, load and the parallel combination of capacitor during the OFF period. During ON Period Capacitor gained energy enables to transfer to load [5].

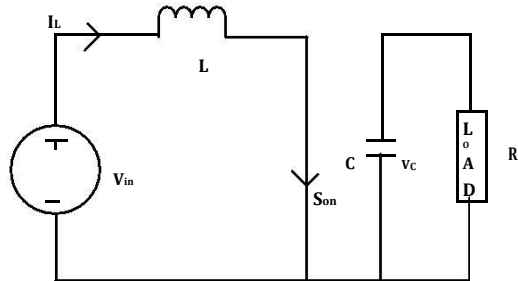

Fig. 2. ON Mode

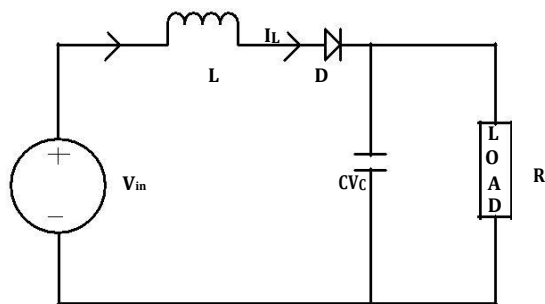

Fig. 3. OFF Mode

B) Buck Converter

Buck converter is a step down DC-DC converter as shown in fig. 4. Buck converter consists of V_s as a dc voltage source as input, inductor L for filter, switch S, diode D and resistive load R. Waveforms of the buck converter are shown in fig. 5, inductor current is at all times positive as per assumption. As per circuit diagram when the switch S is on, the diode D is reverse biased.

When the switch S is OFF, diode D is conduct to provide continuous current to the inductor L. According to Faraday's law the inductor volt-second product is zero, during the steady state operation. For the buck converter

$$(V_s - V_0)DT = V_0 (2D)T \quad (1)$$

So, the transfer function of dc voltage is given as the ratio of the output voltage and the input voltage, is below given

$$M_V = V_0 / V_s = D \quad (2)$$

The input voltage is always greater than the output voltage; this can be seen from Eq. 2

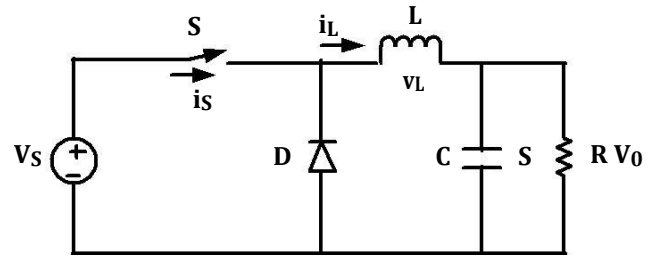

Fig. 4. Buck Converter

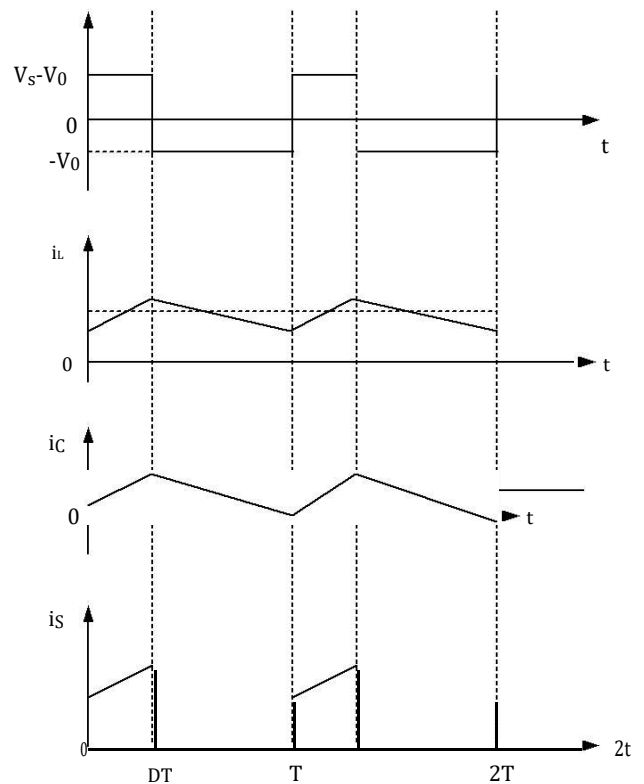

Fig. 5. Buck Converter Waveform

C) Buck-Boost Converter

Buck-boost converter non isolated topology is shown in fig. 6. Buck-boost converter is a cascade connection of buck and boost converter. It consist of voltage source S as input DC voltage, switch S, capacitor C as a filter, diode D and resistance R as a load. Diode D is OFF, when the switch S is on and the inductor current increased.

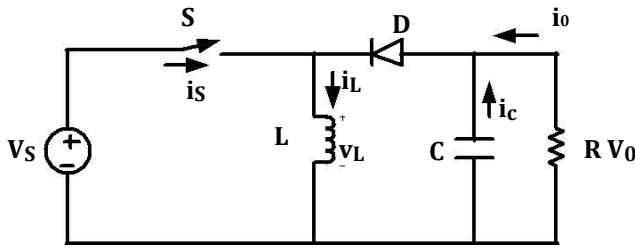

Fig. 6. Buck-Boost Converter

$$MV = V_0 / V_s = D / (1 - D) \tag{4}$$

The magnitude of output voltage can be higher or lower (same at $D = 0.5$) than the input voltage as per the converter name specified. V_0 is the output voltage which is negative with reference to the ground. The boundary between the continuous conduction mode and discontinuous conduction mode is decided by the value of the inductor

$$L_b \geq \frac{R D^2}{2 f} \tag{5}$$

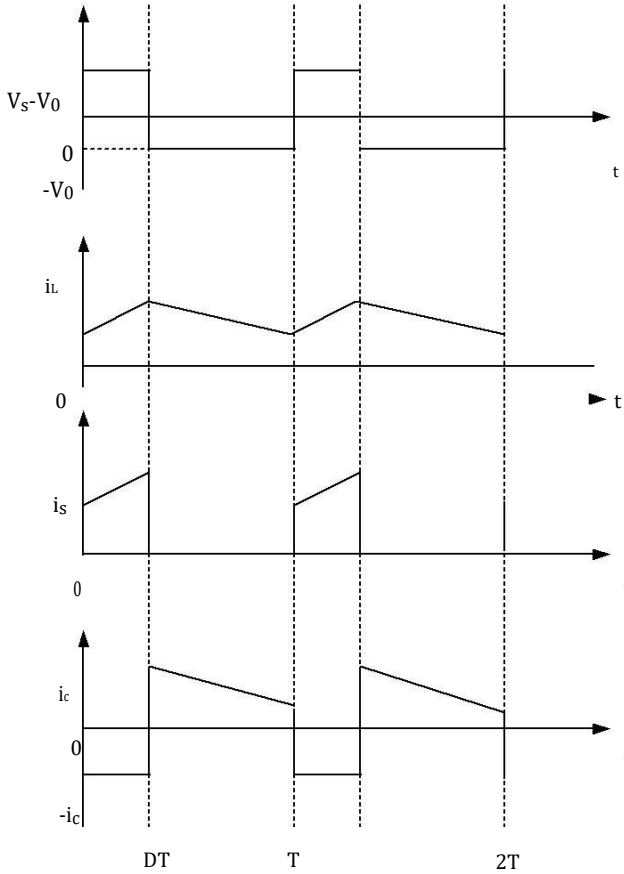

Fig. 7. Buck -Boost Converter Waveform

When switch S is turned off, the diode D provides path for the inductor current. Waveform of the converter is shown in fig. 7. For the inductor in a steady state yields the condition of a zero volt-sec product

$$V_s(D)T = (V_0) (1 - D)T \tag{3}$$

Transfer function of the converter is given as below that is for Buck-Boost converter

The value of the filter capacitor can be obtained from Eq. 5, as the output part of the buck boost converter is similar to that of boost converter.

III. CONTROL TECHNIQUES

A. Proportional, Integral, Differential Controllers (PID)

In various industrial applications proportional, integral and differential controllers organization is most commonly use to improve the performance of the selected control system. Various combination of proportional (P), integral (I) and differential (D) controllers are shown below:

- a) Proportional and Integral Controllers (PI)
- b) Proportional and Derivative controllers (PD)
- c) Proportional Integral and Derivative Controllers

Proportional controllers in which the actual signal is directly proportional to an error signal. An Integral controller in this controller actual signal is directly proportional to the integral of the error signal. Derivative controller in this controller actual signal is directly proportional to the derivative of the error signal [3] [6] [7]. Proportional derivative (PD) controller improves the transient response of the system. Proportional integral (PI) controller reduces steady state error present in the system. The combination of PI and PD controller forms the PID controller, it involves P, I and D three different constant parameters. Signal which is present in between desired output and actual output is an error signal. PID controller operates directly on error signal. Advantages of PID controller are as faster response to change in the control input; control signal increases to lead steady state error towards zero and eliminates oscillations [6]. By tuning the three constant the controller can provide the control action for the specific process. the factors on which the response of the controller depends are the responsiveness of controller for error, degree of system oscillation and the degree at which controller overshoots the set point [7].

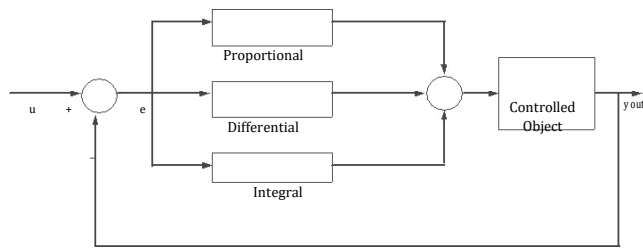

Fig. 4. Block Diagram for PID Controller

For tuning to the PID controller, increasing parameter K_p , K_i and K_d have its own effects, it can be summarized as [7]

TABLE I. MANUAL TUNING SYSTEM

Parameter	Rise Time	Overshoot	Time for Settling	Error Steady State	Stability
K_p	Rise Time Decreases	Increase	No Definite (Minor Changes)	Decrease	Degrade
K_i	Decrease	Increase	Increase	Eliminate	Degrade
K_d	No Definite (Minor Change)	Decrease	Decrease	No Definite (Minor change)	Improve if K_d small

In many case, PID tuning can be done by increasing the parameters K_p , K_i and K_d one by one. Firstly, the system needs to be determining what its characteristic need to be improving. Then the K_p parameter is use to decrease the rise time. After that the parameter K_d is use to reduce the overshoot, settling time and lastly eliminate the steady steady-state error using K_i parameter. When done tuning the parameters, the system need to be examined either it obtain or not acceptable stability. Acceptable stability is when the undershoot that follow the first overshoot of the response is small, or barely observable [7].

B. Proportional, Integral, Differential Controllers (PID) Controller Tuning

PID controller has various types of tuning methods. The selection of Proportional, Integral and Differential depends upon the process model. The selection of technique will depends mostly on type of the system whether or not the system can be taken "offline" for tuning and the response time of input and measuring the output can be done to determine the control parameters.

Typical tuning methods with their advantages and disadvantages are given in the following table

TABLE II. TYPICAL TUNNING METHODS

Methods	Advantages	Disadvantages
(try and error) Manual Tuning	Online method and No math required.	Experienced personnel. neede
Ziegler Nichols	Online method and Proven method.	Process upset, very aggressive tuning, and some trialand-error.
Software Tools	Consistent tuning. Online or offline method. Can support non-steady state (NSS) tuning. Allow simulation before downloading	Training as well as Some cost involved.
Cohen - Coon	Model of Good Process	Only good for first-order processes Offline method.

1) Advantages of PID controllers

PID controller which is independent of the model, simple in design and applicable for various fields has a predominant role in industrial control. Very fast response for change in the control input control signal increases to lead steady state error towards zero also eliminates oscillations

2) Disadvantages of PID controllers

PID controller technique cannot meet increasing requirements for fast dynamic response, high control precision. If there occurrence of uncertainties then the stability of this technique cannot be guaranteed.

C. Sliding Mode Control

Power electronic converters such as DC-DC converters mostly used. By changing the duty cycle of the switches in the circuit converter the sources of direct current changes from one voltage to another voltage level. For the nonlinear system it's become a great challenge for design and control. Classical control methods are not suitable for operating point variations and load disturbances. Variations in the system parameters and large signal transient produce in the system output due to change in the load and large signal transient in the startup cannot allocate with these techniques.

A multi-loop control technique such as CMC, has significantly upgraded the dynamic behavior, but control strategy remains hard specifically for higher level converter topologies [8]. For the complex system encompassing nonlinear dynamics with highly coupled with internal variables, disturbance due to external and parameter suspensions, to meet this consequently advanced nonlinear control system are needed to encounter the challenge [9].

At this point for DC-DC converter sliding mode controller is an effective control method, has variable structure due to switching characteristics. Sliding mode control techniques is totally free from disturbance and constraints and it can provide advantages such as stability against large disturbances, fast dynamic response and very simple implementation [1]. The greatest notable aspect of sliding mode control is the discontinuous nature of its control action which provides outstanding system performance and insensitivity to certain parameter variations and disturbances, finite time conjunction [9]. Sliding mode controller mainly known for their robustness and stability against large disturbances. It can operate at an infinite switching frequency. This challenges the possibility of applying sliding mode controller in power converters due to extreme high speed switching in power converters effects excessive switching losses, inductor and transformer core losses and electromagnetic interference (EMI) [8]. For robot manipulators, automotive transmission underwater vehicles and engines and power systems sliding mode controller is successfully applied [8].

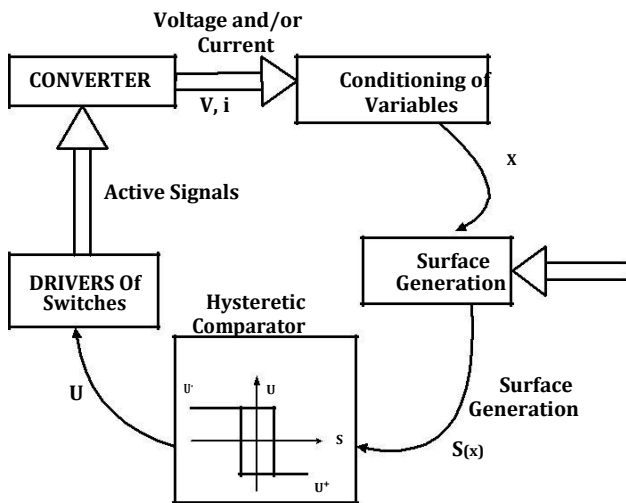

Fig. 5. General Block Diagram Of Sliding controlled Converter

1) Advantages of sliding mode control

Sliding Mode Control is independent of disturbances and constraints. For large disturbances it can provide fast dynamic response and very simple implementation and stability. This can be achieved due to property of acting on all system state variables concurrently.

IV. PROPOSED WORK

The proposed work base on conversion of renewable energy sources like wind energy. Renewable energy sources are freely available in nature. Maximum utilization of these available energy sources must be done for future increasing demand of electrical energy. In this proposed work wind energy use as an ultimate source for this wind turbine going to use for

conversion of wind energy to mechanical energy wind energy is in the form of AC source for converting this AC to DC rectifiers are used. The voltage at the output of the converter is higher than the input. Load is connected across the boost converter. As boost converter are use some control technics are used for controlling purpose. The following block diagram illustrates the proposed work.

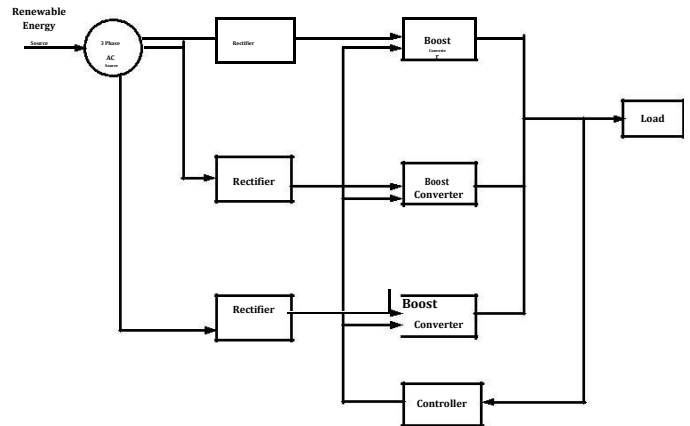

Fig. 6. Proposed work Block Diagram

TABLE III. COMPARISON TABLE BETWEEN THE SLIDING MODE AND PID CONTROLLER

Parameter	Sliding Controller	PID controller
Design	Very simple in design and implementation	Independent of model and simple in design
Operating variations	Respond satisfactorily for the operating point variations and load disturbances	Operate directly on error signals and didn't respond on operating point variations and load disturbances
Response	Sliding mode control is free from disturbances and constraints and provide stability against large disturbances and fast dynamic response	PID controller cannot meet increasing requirements for fast dynamic response, high control precision
Settling time	Settling time is lowest	Settling time is higher than sliding mode controller

V. CONCLUSION

The above paper is reviews of various control techniques of DC-DC Boost Converters. Nonlinear controllers like model predictive control (MPC) and fuzzy controllers are effective while most are complex and they are difficult and expensive for practical applications. Current mode controller designing is not an easy task and the linear control effects are limited. PID Controller technique cannot meet increasing requirements for fast dynamic response,

