

Study of DFIG Connected To Grid Using Wind Energy System

Mr. Ankit R. Umale¹, Mr. Tausif Ahmad Shekh Muktar², Prof. Mr. Rahul K. Kirpane³

¹Student, DES's College of Engineering and technology

²Student, DES's College of Engineering and technology

³Assistant Professor, Dept. of Electrical Engineering, DES's college, Maharashtra, India

Abstract - In recent years, wind energy has become one of the most important and promising sources of renewable energy, which demands additional transmission capacity and better means of maintaining system reliability. The statistical data conveys that Double Fed Induction Generator (DFIG) based wind turbine with variable pitch control is the most common wind turbine in the growing wind market. DFIG wind turbines are nowadays increasingly used in large wind farms because of their ability to supply power at constant voltage and frequency. The Rotor Side Converter (RSC) usually provides active power and reactive power control of the machine while the Grid Side Converter (GSC) keeps the voltage of the DC link constant. This paper presents a study of DFIG driven by a wind turbine connected to grid.

Key Words: Doubly Fed Induction Generator (DFIG), Grid Side Converter, Rotor Side Converter (RSC), Wind energy, wind turbine.

1. INTRODUCTION

Conservation of non-renewable resources motivate to explore the new avenues of resources for electricity generation which could be clean, safe and most valuable to serve the society for a long period. These sources can be better replacement of the polluted non-renewable sources in order to meet the growing demand for power due to rapidly growing economy and expanding population. Currently DFIG wind turbines are increasingly used in large wind farms. DFIG are basically electric machine that are fed ac current into both the stator and rotor windings. Most doubly-fed electric machines in industry today are three-phase wound-rotor induction machines. Although their principles of operation have been known for decades, doubly-fed electric machines have only recently entered into common use. This is due almost exclusively to the advent of wind power technologies for electricity generation. Doubly-fed induction generators (DFIGs) are by far the most widely used type of doubly-fed electric machine, and are one of the most common types of generator used to produce electricity in wind turbines. This paper introduces the basic features and normal operation of DFIG systems for wind power applications basing the description on the standard induction generator. Different aspects that will be described include their variable-speed feature, power converters and their associated control systems. A three-phase wound-rotor

induction machine can be setup as a doubly-fed induction motor. Grid connected DFIG develop there excitation from the utility grid.

2. PROBLEMS WITH WIND POWER GENERATION AND DFIG

In 1998, Norway commissioned a study of wind power in Denmark and concluded that it has "serious environmental effects, insufficient production, and high production costs." Wind power industry is developing rapidly, more and more wind farms are being connected into power systems. Integration of large scale wind farms into power systems presents some challenges that must be addressed, such as system operation and control, system stability, and power quality. The available power depends on the wind speeds, but it is important to be able to control and limit the power at higher wind speed to avoid damage. A turbine could be design in such way that it converts as much power as possible in all wind speeds.

On the general level, voltage variations are the main problem associated with wind power. This can be main limiting factor on the amount of wind power which can be installed. The real power generation of a wind turbine can be regulated down but it may be difficult to increase the power output since the input power is limited by the wind speed. System stability is mainly associated with power system faults in a network such as tripping of transmission lines, loss of production capacity and short circuit. These failures disrupt the balance of power and change of power flow. Also the problem of harmonics arises in the production of wind power. Our main aim is that to abstract maximum available power from the wind and produced harmonics has to be reduced. By using proper smoothening the produced output harmonics has to be reduced. By using accurate techniques the produced outputs should be matched with grid requirements and the power should be delivered keeping the power quality improved. For the following purpose Doubly fed induction generator are used with back to back converter. The smoothening chokes will work to reduce the harmonics present in the generated power output. The Rotor Side Converter

(RSC) usually provides active power and reactive power control of the machine while the Grid Side Converter (GSC) keeps the voltage of the DC link constant. The back to back converter employed here will solve the power flickering.

3. DFIG SYSTEM DISCRIPTION

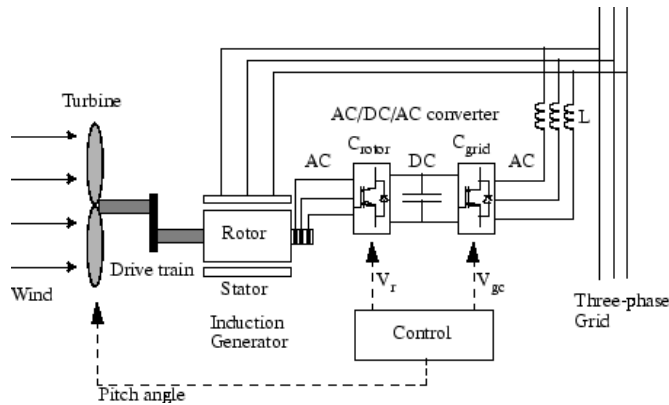

Fig-1:DFIG and Wind Turbine System

3.1 Wind turbine system

Wind turbines produce electricity by using the power of the wind to drive an electrical generator. Wind passes over the blades, generating lift and exerting a turning force. The rotating blades turn a shaft inside the nacelle, which goes into a gearbox. The gearbox increases the rotational speed to that which is appropriate for the generator, which uses magnetic fields to convert the rotational energy into electrical energy. The power output goes to a transformer, which converts the electricity from the generator at around 700V to the appropriate voltage for the power collection system, typically 33 kV. A wind turbine extracts kinetic energy from the swept area of the blades. Based on axis of rotation there are two types of wind turbine.

1. Horizontal-axis turbines.
2. Vertical-axis turbines.

The doubly fed induction generator commonly uses the horizontal-axis turbine as shown in fig.2.

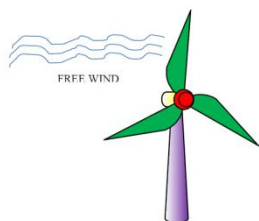

Fig-2: Horizontal axis turbine

3.2 Doubly fed induction genrator

Doubly fed induction generators are similar to ac electrical generators but have an additional feature which allows them to run at speeds slightly above or below their natural speed. This is useful for large variable speed wind turbines because

wind speed can change suddenly. There are two three phase windings one stationary winding and one rotating winding both are separately connected to the equipment's outside the generator thus the term "doubly fed" is used. Stator winding is directly connected to the output and produce three phase ac power at the desired grid frequency. The rotor winding is connected to three phase ac power, at variable frequency (in general the dc excitation is given but DFIG uses ac excitation). The rotor windings connected to grid via slip rings and bidirectional back to back voltage converter that controls both the rotor and grid currents and thus the frequency can be control.

3.3 Working principle of DFIG

In DFIG we give the ac current to the rotor winding instead of dc. The magnetic field passing through the stator winding not only rotate due to the rotation of the generator rotor but also due to rotational effect produced by ac currents fed into rotor windings therefore in DFIG both the rotational speed of the rotor (N_{rotor}) and the frequency of the ac currents passing through the rotor windings (F_{ac}) determine the speed of the magnetic field passing through the stator (N_{stator}) and therefore the frequency of the generated alternating voltage. The main reason for using the DFIG is generally to produce three phase voltage whose frequency is constant equal to the frequency of the grid ($F_{network}$).

Therefore to achieve this there must be a continuous adjustment made in frequency F_{ac} of the ac currents fed into the rotor windings to counter any variations in the rotor speed N_{rotor} caused by fluctuation of rotor speed. The frequency F_{ac} of the ac currents that need to be fed into the DFIG rotor windings depends on the speed of the generator rotor. The frequency F_{ac} is given by,

$$F_{ac} = F_{network} - \frac{(N_{rotor} \times p)}{120}$$

Consider DFIG with four number of magnetic poles supplying power to 50hz network and the rotor speed is given by 1680 rpm then F_{ac} is given by,

$$F_{ac} = 50 - \frac{1680 \times 4}{120} = -6 \text{ hz}$$

The negative polarity of the frequency indicates that the magnetic field created in the rotor winding must rotate in the direction opposite to the direction of rotor.

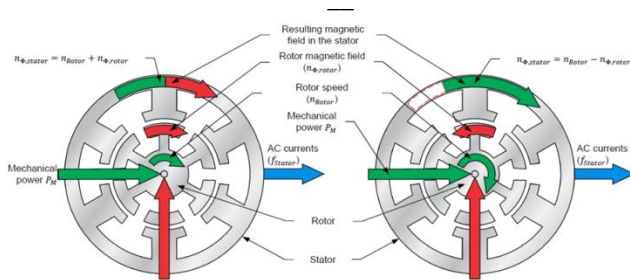

Fig-3: Interaction between the rotor speed and the frequency of the rotating magnetic field

For maintaining the generated voltage in stator winding equal to the grid or network voltage the magnitude of the magnetic flux must be maintained in the stator winding. This can be achieved by applying a voltage that is proportional to the frequency of the voltage applied to the rotor winding which maintain the $\frac{V}{f}$ ratio constant and ensures a constant magnetic flux value in the machine.

3.4 Back to back converter

The back-to-back converter comprises separate machine side and grid side portions which are connected with each other via dc link capacitor. The grid side converter transfers the active power from the machine side converter into the grid. rotor windings are connected to the grid via slip rings and back to back voltage source converter that control both the rotor and grid currents thus the frequency of the rotor winding current can be control using back to back converter [5].

RESULT

From the above study we can understand that the Doubly fed induction generator used for wind energy conversion system is more reliable and efficient than other wind turbine generator. Doubly fed induction generator proved to be more reliable and stable system when connected to grid side with the proper converter control systems.

CONCLUSION

DFIG is used in Wind farms because of their ability to supply power at constant voltage and frequency. For best efficiency the DFIG system is used which is connected to grid side and has better control. The rotor side converter usually provides active and reactive power control of the machine side while the grid side converter keeps the voltage of dc link constant. The faults can occur when wind speed decreases to a low value or it has persistent fluctuations. The DFIG is able to provide a considerable contribution to grid voltage support during short circuit periods.

REFERENCES

- [1] Nicholas W. Miller, Juan J. Sanchez-Gasca, William W. Price, & Robert W. Delmerico, "Dynamic Modelling Of GE 1.5 and 3.6 Mw Wind Turbine-Generators For Stability Simulations," *GE Power Systems Energy Consulting, IEEE WTG Modelling Panel, Session July 2003*, pp.1977-1983.
- [2] S. Muller, M. Deicke, & Rik W. De Doncker, "Doubly Fed Induction Generator Systems For Wind Turbines," *IEEE Industry Applications Magazine*, May/June 2002, pp.26-33.
- [3] Satish Choudhury, Kanungo Barada Mohanty, B.Chitti Babu, "Performance Analysis of Doubly-Fed Induction Generator for Wind Energy Conversion System," *Proc. PSU-UNS International Conferene of Engineering and Technology(ICET-2011)*, Phuket, Thailand, May 2011, pp.532-536.
- [4] Sherihan Ashraf Shaheen, Hany M. Hasanien, and M. Abd-El-LatifBadr, "Study on Doubly Fed Induction Generator Control," *Proceeding Of The 14th International Middle East Power Systems Conference*, Cairo University, Egypt, Dec 19-21, 2010, pp.627-633.
- [5] Olimpo Anaya lara, Nick Jenkins, Jnaka Ekanayake, Phill Cartwright Mick Hughes, Book "Wind energy generation: Modeling And Control", John Wiley And Sons Ltd,2009.
- [6] B. Chitti Babu, K. B. Mohanty, "Doubly-fed induction generator for variable speed wind energy conversion systems- modeling & simulation", *International Journal of Computer and Electrical Engineering*, Vol. 2, No. 1, pp. 141-147, February 2010.
- [7] Andreas Petersson, Torbjörn Thiringer, Lennart , Harnefors, Tomáš Petrů, "Modeling and experimental verification of grid interaction of a DFIG wind turbine", *IEEE Transactions on Energy Conversion*, vol. 20, no. 4, pp. 878-886, Dec. 2005.