

VOLTAGE SAG COMPENSATION USING DYNAMIC VOLTAGE RESTORER

Ms. Ashwini R. Patil¹, Prof. G. K. Mahajan², Prof. N. S. Wani³

¹Student (ME), Dept. of Electrical Engineering, SSGB COET, Bhusawal, Maharashtra, India.

²Assistant Professor, Dept. of Electrical Engineering SSGB COET, Bhusawal, Maharashtra, India.

³Assistant Professor, Dept. of Electrical Engineering SSGB COET, Bhusawal, Maharashtra, India.

Abstract - The power quality (PQ) requirement is one of the most important issues for power companies and their customers. There are various power quality disturbances like voltage sag, swell, notch, spike and transients etc. Out of these the voltage sag and swell is very severe problem for an industrial customer which needs urgent attention for its compensation. There are various methods for the compensation of voltage sag and swell. A new topology is proposed in this paper for the compensation of voltage sags in power distribution systems. Voltage sag is one of the major power quality problems encountered by most industries. One of the most popular methods of sag and swell compensation is Dynamic Voltage Restorer (DVR), which is used in both low voltage and medium voltage applications. This paper presents the comprehensive reviews of various articles, the advantages and disadvantages of each possible configuration. The compensation strategies have been presented aiming at fast response, accurate compensation and low costs. This review will help the researchers to select the optimum control strategy and power circuit configuration for DVR applications. This will also very helpful in finalizing the method of analysis and recommendations relating to the power quality problems.

Key Words: Power quality, Dynamic Voltage Restorer, Compensation Techniques...

1. INTRODUCTION

The various power quality issues and resulting problems are consequences of the increasing use of solid state switching devices, nonlinear and power electronically switched loads, electronic type loads. The advent and wide spread of high power semiconductor switches at utilization, distribution and transmission lines have non sinusoidal currents [1]. The electronic type load causes voltage distortions, harmonics and distortion. Power quality problems can cause system equipment malfunction, computer data loss and memory mal function of the sensitive equipment such as computer, programmable logic devices [PLC] controls, and protection and relaying equipment [1]. Voltage sag and swell have proven to be most wide spread power quality issues affecting distribution systems, especially industries, where involved losses can reach very high values. Short and shallow voltage sag can produce dropout of a whole industry. In general, it is possible to

consider the origin of 10 to 90% power quality problems arises from voltage sag and swell [2]. Voltage sag are mainly caused by faults and short circuits, lightning strokes, and inrush currents and swell can occur due to a single line-to-ground fault on the system, which can also result in a temporary voltage rise on the unfaulted phases [3].

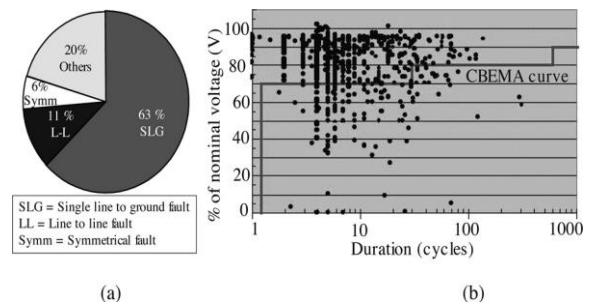

Fig-1. (a) Various faults in power system. (b) Semiconductor industry voltage sag study with the CBEMA curve.

Voltage sag is known to produce the most devastating impact on the loads, among different types of disturbances occurring in power system. Various studies show that 92% of all disturbances in the electrical power distribution systems are voltage sags, transients, and momentary interruptions [1],[2]. More than 1500 distinct events studied by "i-grid.com" (mostly from large industrial plants located around the U.S. and Canada) were analyzed in detail [3]. Fig. 1(a) shows the statistics of the measured events, indicates that 63% of the disturbances were single line- to-ground (SLG) faults and 11% were line-to-line (LL) faults [4]. Though symmetrical faults (Symm) were 6%, deep symmetrical three-phase voltage sags were very rare [1]. Most of the three-phase symmetrical faults create symmetrical sag depth less than 50%. A separate study was also conducted by Semiconductor Equipment and Material International (SEMI) organization, and the collected data with the CBEMA curve overlaid is shown in Fig. 1(b). Voltage sags are characterized by sag depth, phase jump, and duration of sag. The need for better power quality has prompted the end users to install power conditioning equipment to mitigate voltage sags. One such series custom power device is dynamic voltage restorer (DVR) [5], [6].

DVR is a custom power device which can be efficiently used for the improvement of power quality in the distribution system for voltage disturbances such as voltage

sags, swells, harmonics, and unbalanced voltage. DVR is a protection device whose main function is to protect the precision manufacturing process and sophisticate sensitive electronic equipments from the voltage fluctuation and power outages [4]. The DVR has been proposed and developed by Westinghouse for advance distribution. The DVR is able to inject a set of three single-phase voltages of an appropriate magnitude and duration in series with the supply voltage in synchronism through injection transformer to restore the power quality. The DVR is a series conditioner based on a pulse width modulated voltage source inverter, which is generating or absorbing real or reactive power independently. Voltage sags caused by unsymmetrical line-to-line, line to ground, double-line-to-ground and symmetrical three phase faults is affected to sensitive loads, the DVR injects the independent voltages to restore and maintained sensitive to its nominal value. The injection power of the DVR with zero or minimum power for compensation purposes can be achieved by choosing an appropriate amplitude and phase angle [4] [5]. Section 2 discusses the basic configuration of DVR. The various operating modes of DVR are discussed in section 3. Section 4 presents the different compensation techniques of dynamic voltage restorer and section 5 discusses the conclusion.

2. DYNAMIC VOLTAGE RESTORER

Dynamic Voltage Restorer is series connected voltage source converter based compensator which has been designed to protect sensitive equipments like Programmable Logic Controllers (PLCs), adjustable speed drives etc from voltage sag and swell. Its main function is to monitor continuously the load voltage waveform constantly by injecting missing voltage in case of sag/swell [4] [5]. The above function is achieved by creating a reference voltage which is similar in magnitude and phase angle to that of supply voltage. Any abnormality of voltage waveform can be detected by comparing the reference and the actual waveform of the voltage. DVR cannot mitigate voltage interruption because it is being a series connected device. A Dynamic Voltage Restorer is connected in series with the network and basically it is a controlled voltage source converter. It injects a voltage on the system to compensate any disturbance affecting the load voltage. The compensation capability of DVR depends upon the maximum voltage injection ability and real power supplied by it. Whenever voltage sag occurs, the real power requirement is fed by energy storage devices like batteries and SMES [6]. Whenever there is fault occurred on any feeder, DVR injects series voltage and compensates load voltage to pre-fault voltage. A basic block diagram for open loop DVR is shown in fig.1 [6][7].

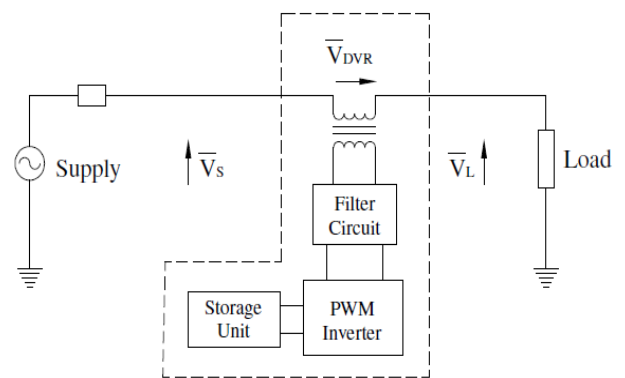

Fig-2 Dynamic Voltage Restorer (DVR) schematic diagram

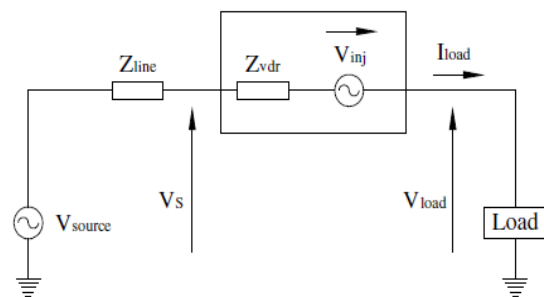

Fig-3 Equivalent circuit of DVR

Figure 2 shows the equivalent circuit of the DVR, when the source voltage is drop or increase, the DVR injects a series voltage V_{inj} through the injection transformer so that the desired load voltage magnitude V_{Load} can be maintained [4] [7]. The series injected voltage of the DVR can be written as:

$$V_{inj} = V_{Load} + V_s \dots\dots\dots(1)$$

Where,

V_{Load} is the desired load voltage magnitude.

V_s is the source voltage during sags/swells condition.

The basic principle of the dynamic voltage restorer is to inject a voltage of required magnitude and frequency, so that it can restore the load side voltage to the desired amplitude and waveform even when the source voltage is unbalanced or distorted. Generally, DVR incorporates a gate turn off thyristor (GTO) solid state power electronic switches in a pulse width modulated (PWM) inverter structure.

The DVR is able to generate or absorb independently controllable real and reactive power at the load side. In other words, the DVR employs a solid state DC to AC switching power converter whose function is to inject a set of three phase AC output voltages in series and synchronism with the distribution and transmission line voltages. The injected voltage is obtained from the

commutation process for reactive power demand and an energy source for the active power demand [4] [7]. This energy source may vary according to the design and manufacturer of the DVR. And these energy sources applied are batteries, DC capacitors and that drawn from the line through a rectifier.

The general configuration of the DVR consists of the following equipment:

- (a) Series injection transformer
- (b) Energy storage unit
- (c) Inverter circuit
- (d) Filter unit
- (e) DC charging circuit
- (f) A Control and Protection system

2.1 Energy Storage Unit:

Energy storage device is used to supply the real power requirement for the compensation during voltage sag. Energy storage devices generally employed can be a lead acid battery, a superconducting magnetic energy storage (SMES), a flywheel and a super-capacitor. For DC drives such as SMES, batteries and capacitors, ac to dc conversion devices (solid state inverters) are required to deliver power, while for others, ac to ac conversion is needed. For particular voltage sag, the maximum compensation ability of the DVR is dependent on the amount of the active power supplied by the energy storage devices. Lead acid batteries are having high response during charging and discharging hence being popular among the others. But their discharge rate is dependent on the chemical reaction rate of the battery so that the available energy inside the battery is determined by its discharge rate.

2.2 Voltage Source Inverter:

Generally Pulse-Width Modulated Voltage Source Inverter (PWMVSI) is used. The main purpose of Voltage Source Inverter is to convert the DC voltage supplied by the energy storage device into an AC voltage. A step up voltage injection transformer is employed in DVR power circuit. Hence, a VSI with a low voltage rating is enough.

2.3 Passive Filters:

Low pass passive filters are used to convert the PWM inverted pulse waveform into a sinusoidal waveform. This is achieved by removing the unnecessary higher order harmonic components generated from the DC to AC conversion in the VSI, which will distort the compensated output voltage. These filters can be placed either in the high voltage or in the low voltage side of the injection transformers.

When the filters are in the inverter side higher order harmonics are prevented from passing through the voltage

transformer. And it reduces the stress on the injection transformer. But the inverted output obtained can contain a phase shift and voltage drop. This can be reduced by placing the filter in the load side. But in this case since the higher order harmonic currents do penetrate to the secondary side of the transformer, a higher rating of the transformers necessary. However the leakage reactance of the transformer can be used as a part of the filter, which will be helpful in tuning the filter.

2.4 Bypass Switch:

Since the DVR is a series connected device, any fault current that occurs due to a fault in the downstream will flow through the inverter circuit. As the power electronic components in the inverter circuit are much costly to be overrated, hence they are normally rated to the load current. Therefore a by-pass switch (crowbar circuit) is incorporated to by-pass the inverter circuit in order to protect the inverter from high currents. The basic function of the crowbar circuit is to sense the current flowing in the distribution circuit and if it is beyond the inverter current rating the circuit bypasses the DVR circuit components (DC Source, inverter and the filter) thus eliminating high currents flowing through the inverter side. And When the supply current is in normal operating condition, the crowbar circuit will become inactive.

2.5 Voltage Injection Transformers:

The high voltage side of the injection transformer is connected in series to the distribution line, while the low voltage side is connected to the DVR power circuit. Three single-phase or three-phase voltage injection transformers can be connected to the distribution line for a three-phase DVR and for single phase DVR one single-phase transformer is connected. For the three-phase DVR the three single-phase transformers can be connected either in delta/open or star/open configuration.

3. OPERATING MODES OF DVR

The basic function of the DVR is to inject a dynamically controlled voltage VDVR generated by a forced commutated converter in series to the bus voltage by means of a booster transformer. The transient amplitudes of the three injected phase voltages are controlled such as to remove any detrimental effects of a bus fault to the load voltage [8]. This means that any differential voltages caused by momentary disturbances in the ac feeder will be compensated by an equivalent voltage generated by the converter and they are injected on the medium voltage level through the booster transformer [4] [8]. The Dynamic Voltage Restorer is basically operated three modes of operation which are: protection mode, standby mode, injection/boost mode.

3.1. PROTECTION MODE

If the over current on the load side exceeds a permissible limit due to short circuit on the load or large inrush current, the DVR will be isolated from the systems by using the bypass switches (S2 and S3 will open) and supplying another path for current (S1 will be closed) as shown in fig-4 [4] [8].

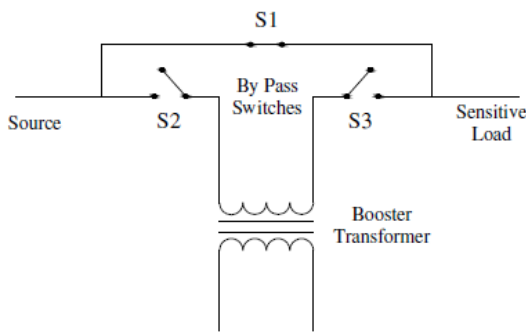

Fig-4 Protection Mode (creating another path for current)

3.2. STANDBY MODE: (VDVR = 0)

In the standby mode, the low voltage winding of the booster transformer is shorted through the converter. There is no switching of semiconductors occurs in this mode of operation and the full load current will pass through the primary as shown in fig- 5 [8] [9].

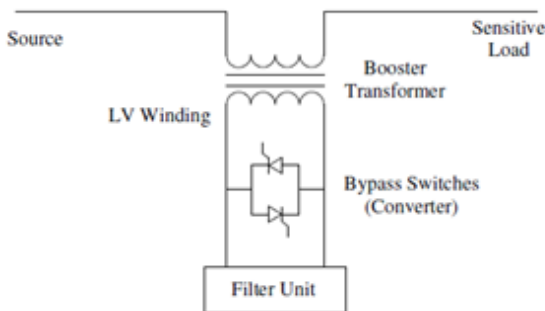

Fig- 5 Standby Mode

3.3. INJECTION/BOOST MODE: (VDVR>0)

In the Injection/Boost mode the DVR injects a compensating voltage through the booster transformer whenever the disturbance is detected in the supply voltage [8] [9].

4. COMPENSATION TECHNIQUES IN DVR

Voltage injection or compensation methods by means of a DVR depend upon the limiting factors such as; DVR power ratings, various conditions of load, and different types of voltage sags. Some loads are sensitive towards phase angle jump and some are sensitive towards change in magnitude and others are tolerant to these. There are three different voltage injection techniques of DVR as follows:

- (a) Pre-sag compensation Technique
- (b) In-phase compensation Technique
- (c) In-phase advanced compensation Technique

4.1. PRE-SAG/DIP COMPENSATION TECHNIQUE:

The pre-sag method tracks the supply voltage continuously and if it detects any disturbances in supply voltage it will inject the difference voltage between the sag or voltage at PCC and pre-fault condition, so that the load voltage can be restored back to the pre-fault condition. Voltage sag compensation in sensitive loads for both phase angle and amplitude would be achieved by pre-sag compensation method as shown in fig- 6 [12] [13]. In this compensation technique, the injected active power cannot be controlled and it is determined by external conditions such as the type of faults and load conditions. The voltage of DVR is given below:

$$VDVR = V_{prefault} - V_{sag} \quad (2)$$

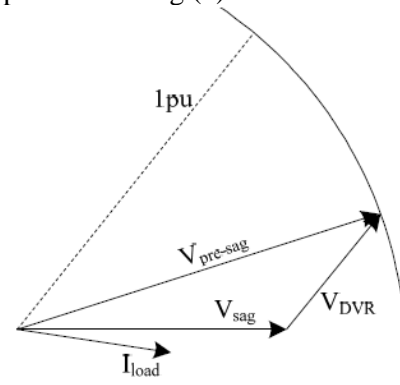

Fig-6 Pre-sag Compensation Technique

4.2. In-Phase Compensation Technique:

This is the most straight forward method. In this method the injected voltage is in phase with the supply side voltage irrespective of the load current and pre-fault voltage as shown in fig- 7. The phase angles of the pre-sag and load voltage are different but the most important criteria for power quality that is the constant magnitude of load voltage are satisfied [12] [13]. The load voltage is given below:

$$|V_L| = |V_{prefault}| \quad (3)$$

One of the advantages of this method is that the amplitude of DVR injection voltage is minimum for certain voltage sag in comparison with other strategies. Practical application of this method is in non sensitive loads to phase angle jump.

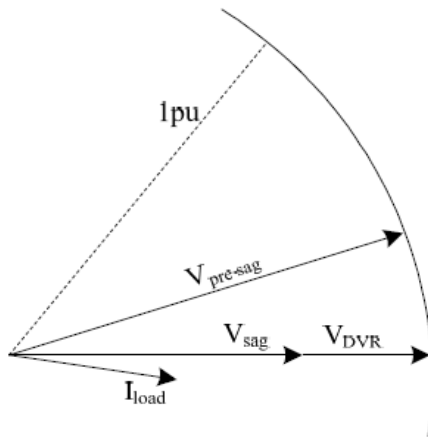

Fig-7 In-phase Compensation Technique

4.3. In-Phase Advanced Compensation Technique:

In this technique, by the minimization of power angle between sag voltage and load current, the real power spent by the DVR is decreased. In case of pre-sag and in-phase compensation method the active power is injected into the system during disturbances. And the source of active power is limited stored energy in the DC links and this part is being one of the most expensive parts of DVR. The minimization of injected energy is achieved by making the active power component zero by having the injection voltage phasor perpendicular to the load current phasor. In this technique, the values of load current and voltage are fixed in the system so that we can change only the phase of the sag voltage. IPAC method uses only reactive power and unfortunately, not all the sags can be mitigated without real power, as a consequence, this method is only suitable for a limited range of sags [12] [13] [14].

5. CONCLUSION

In this paper, a new voltage sag supporter, has been proposed to compensate voltage sag. This paper has presented an exhaustive literature survey on performance of DVR. The above survey shows that the DVR is suitable for compensation of voltage sag and swell by the use of different controlling techniques. The existing topologies, basic structure of DVR, operating modes, compensation techniques have been elaborated in detail. The main advantages of DVR are low cost, simpler implementation; require less computational efforts and its control is simple as compared to other methods. This study also gives useful

knowledge for the researchers to develop a new design of DVR for voltage disturbances in electrical system. From the literature survey of DVR applications, this work concluded that the trends of DVR through the years are still assumed as a powerful area of research.

REFERENCES

- [1] Chellali Benachaiba, Brahim Ferdi "Voltage Quality Improvement Using DVR" Electrical Power Quality and Utilization, Journal Vol. XIV, No. 1, 2008.
- [2] Dash P.K., Panigrahi B.K., and Panda G., "Power quality analysis using S-transform", IEEE Trans. On Power Delivery, vol. 18, no. 2, pp. 406-411, 2003.
- [3] Dash P.K., Swain D.P., Liew A.C. and Raman S., "An adaptive linear combiner for on-line tracking of power system harmonics", IEEE Trans. on Power Systems, vol. 11, no.4, pp.1730-1736, 1996.
- [4] Amit Kumar Jena, Bhupen Mohapatra, Kalandi Pradhan, "Modeling and Simulation of a Dynamic Voltage Restorer (DVR)", Project Report, Bachelor of Technology in Electrical Engineering, Department of Electrical Engineering, National Institute of Technology, Rourkela, Odisha-769008
- [5] Rosli Omar, N.A. Rahim and Marizan Sulaiman, "Dynamic Voltage Restorer Application for Power Quality Improvement in Electrical Distribution System: An Overview", Australian Journal of Basic and Applied Sciences, 5(12): 379-396, ISSN 1991-8178, 2011.
- [6] Margo P., M. Heri P., M. Ashari, Hendrik M. and T. Hiyama, "Compensation of Balanced and Unbalanced Voltage Sags using Dynamic Voltage Restorer Based on Fuzzy Polar Control", International Journal of Applied Engineering Research, ISSN 0973-4562 Volume 3, Number 3, pp. 879-890, 2008.
- [7] M.V.Kasuni Perera, "Control of a Dynamic Voltage Restorer to compensate single phase voltage sags", Master of Science Thesis, Stockholm, Sweden, 2007.
- [8] N. Hamzah, M. R. Muhamad, and P. M. Arsad, "Investigation on the effectiveness of dynamic voltage restorer for voltage sag mitigation", the 5th scored, Malaysia, pp 1-6, Dec 2007
- [9] Rosli Omar, Nasrudin Abd Rahim, Marizan Sulaiman, "Modeling and simulation for voltage sags/swells mitigation using dynamic voltage restorer (dvr)", Journal of Theoretical and Applied Information Technology, JATIT, 2005 - 2009.
- [10] J. G. Nielsen, M. Newman, H. Nielsen, and F. Blaabjerg, "Control and testing of a dynamic voltage restorer (DVR) at medium voltage level", IEEE Trans. Power Electronics, vol. 19, no. 3, p.806, May 2004.
- [11] A. Ghosh and G. Ledwich, "Power Quality Enhancement Using Custom Power Devices", Kluwer Academic Publishers, 2002.
- [12] P. Boonchiam and N. Mithulananthan, "Understanding of Dynamic Voltage Restorers through MATLAB Simulation", Thammasat Int. J. Sc. Tech., Vol. 11, No. 3, July-Sept 2006.
- [13] Ghosh, A. and G. Ledwich, 2002. Compensation of Distribution System Voltage Using DVR, IEEE Trans on Power Delivery, 17(4): 1030-1036.

- [14] Rosli Omar, Nasrudin Abd rahim, Marizan Sulaiman
"Modeling and Simulation for Voltage Sags/Swells Mitigation using Dynamic Voltage Restorer (dvr)", journal of theoretical and applied information technology: 2005 – 2009.
- [15] A. Ghosh and G. Ledwich, "Power Quality Enhancement Using Custom Power Devices", Kluwer Academic Publishers, 2002.