

Design and Comparative Analysis of Controller for Non Linear Tank System

Janaki.M¹, Soniya.V², Arunkumar.E³

^{1,2}Assistant professor, Department of EIE, Karpagam College of Engineering, Coimbatore, India

³ Associate professor, Department of EIE, Karpagam College of Engineering, Coimbatore, India

Abstract: This paper proposes an idea for designing PI Controller and Adaptive controller for non linear system such as Conical Tank System. Conical tank level process was studied experimentally to obtain the process model. From the process model different control schemes such as Z-N tuned controller, IMC Tuned PI controller and Adaptive PI Controller were implemented in MATLAB environment. Among these Controller Adaptive Controller resulted with minimum rise time, settling time, and overshoot.

Keywords: Conical Tank System, Modeling, Controller Design, IMC tuning, Model Reference Adaptive Controller (MRAC).

1.INTRODUCTION

Many industries uses conventional conical tank such as cylindrical tank, cylindrical tank with conical bottom. In the process industries control of liquid level is the basic problem. The rate of change of flow from one tank to another as well as the level of the fluid is two important operational factor .In many processes such as distillation columns, evaporators, re boilers and mixing tanks, the particular level of liquid in the vessel is of great importance in process operation. A level that is too high may upset reaction equilibrium, cause damage to equipment or result in spillage of valuable or hazardous material. If the level is too low it may have bad consequences for the sequential operations. So control of liquid level is an important and common task in process Industries. The level control of the conical tank is difficult because of its nonlinearity and constantly varying cross section. Many of the control deals with the design of linear controllers for linear systems. The PI and PID controllers are widely used in many industrial

control systems because of simple structure and robustness. we are going to discuss about the Adaptive Controller for better performance.

1.1 Block Diagram

The level of the conical tank should be maintained at a desired value. The Controller is designed for the non-linear system and implemented using MATLAB software. The automatic process control block diagram is shown in the Fig 1.

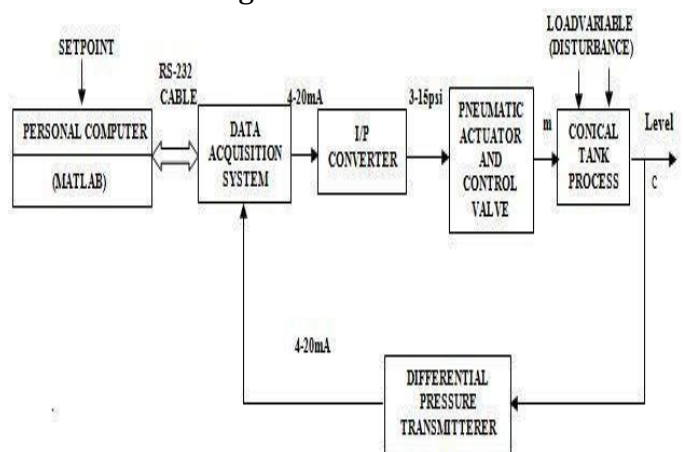

Fig-1: Block Diagram

The conventional PI controllers are used in most of the industrial applications because of its simple structure and robustness. When it comes to the control of conical tank systems and multivariable processes, the controller parameters should be adjusted continuously.

The conical tank is made up of stainless steel and it is mounted vertically on the stand. The water enters into the tank from the top and leaves to the reservoir, which is placed at the bottom of the tank. The level of the water in the conical tank is quantified by means of the differential pressure transmitter. The quantified level of water in the form of current in the range

of (4-20) mA is sent to the DAQ in which ADC converts the analog data to digital data and feed it to the Personal computer. The Personal computer acts as the controller and data logger. The DAC module of the DAQ converts this manipulated variable to analog form into 4-20 mA current signals. The I/P converter converts the current signal to pressure in the range of (3-15) psi, which regulates the flow of water into the conical tank based on the outflow rate of the tank.

2. MATHAMATICAL MODELLING

A mass-balance equation of the control process is given by the rate of change of volume in a tank which is given by the difference between the in-flow and outflow of the tank. The process can be considered as conical tank in which the level of liquid is to maintain at a desired value. This is achieved by controlling in-flow of the conical tank. Since the cross-section area is not constant but it is a function of height. There exists a non-linear relation between the in-flow to the tank and level of the tank which makes the level control a difficult task.

Table-1: operating parameters of conical tank

S.No	Notation	Description	Parameters
1	H	Height	60 cm
2	R	Top radius	17.6 cm
3	r	Bottom radius	2 cm
4	Q	Maximum Flow rate	440 LPH
5	Kv	Valve coefficient	15.48cm ³ /sec

Mathematical modeling of conical tank:

Mass balance equation is,

Accumulation = Input flow - Output flow

$$\frac{dv}{dt} = Q_{in} - Q_0$$

$$A \frac{dh}{dt} = Q_{in} - Q_0$$

Q - Inflow rate

Q₀ - Outflow rate

R - Maximum radius of the tank

r - Bottom radius of the tank

H - Maximum height of tank

h - Height of tank at Steady state

Where A is the Area of the Tank

$$A = \pi r^2$$

Radius and height varied in every one of the tank.

Tangent angle will be,

$$\tan \theta = \frac{r}{h} = \frac{R}{H}$$

$$r = \frac{Rh}{H}$$

$$(\pi r^2) \frac{dh}{dt} = Q_{in} - Q_0$$

$$\left(\pi \left(\frac{Rh^2}{H} \right) \right) \frac{dh}{dt} = Q_{in} - Q_0$$

$$\frac{dh}{dt} = \frac{Q_{in} - Q_0}{\pi \left(\frac{Rh}{H} \right)^2}$$

$$\frac{dh}{dt} = Q_{in} \frac{1}{\pi} \frac{H^2}{(Rh)^2} - Q_0 \frac{1}{\pi} \frac{H^2}{(Rh)^2}$$

$$\alpha = \frac{1}{\pi} \left(\frac{H}{R} \right)^2$$

$$\frac{dh}{dt} = \frac{Q_{in} \alpha}{h^2} - \frac{Q_0 \alpha}{h^2}$$

$$\frac{dh}{dt} = \alpha Q_{in} h^{-2} - K_v \alpha h^{-\frac{3}{2}}$$

$$\frac{dh}{dt} = \alpha Q_{in} h^{-2} - \beta h^{-\frac{3}{2}}$$

Above equation is Non linear form, Linearization is done using Taylor series.

Linearization of $Q_{in} h^{-2}$ is,

$Q_{in} h^{-2}$ is a function of (h,Q)

$$f(h, Q) = f(h_s - Q_s) + \frac{\partial f(h - h_s)}{\partial h} + \frac{\partial f(Q - Q_s)}{\partial Q}$$

h_s, Q_s are steady state values.

Linearization of $\beta h^{-\frac{3}{2}}$ is,

$$h^{\frac{-3}{2}} = h^{\frac{-3}{2}} - \frac{3}{2} h^{\frac{-5}{2}} (h - h_s)$$

Applying steady state values,

$$\frac{dh}{dt} = \frac{\alpha(Q_{in} - Q_o)}{h^2} - \beta \left(h^{\frac{-3}{2}} - \frac{3}{2} h^{\frac{-5}{2}} (h - h_s) \right)$$

$$\tau = \frac{2h^{\frac{5}{2}}}{3\beta}$$

$$k = \frac{2\alpha h^{\frac{5}{2}}}{\beta}$$

$$y = (h - h_s)$$

$$U = (Q - Q_s)$$

So the equation will be,

$$\tau \frac{dy}{dt} + y = kU$$

Above equation implies that the conical tank system is First Order System.

$$K_p = \frac{1}{k} \frac{\tau}{t_d} \left(0.9 + \frac{t_d}{12\tau} \right)$$

$$T_i = t_d \left(\frac{30 + 3 \frac{t_d}{\tau}}{9 + 20 \frac{t_d}{\tau}} \right)$$

The loop is made open and a step increment (230 LPH) is given in inflow rate. Readings should be noted till the system reaches the steady state value. The approximate transfer function of the system is obtained by using process reaction curve method. The single transfer function is obtained using process reaction curve method is expressed by equation

$$G(s) = \frac{0.035e^{-14s}}{16s + 1}$$

3. CONTROLLER DESIGN

In the past, controllers were analog. Nowadays, many of the controllers use digital signals and computers. When a mathematical model of a system is available, the parameters of the controller can be explicitly determined. However, when a mathematical model is unavailable, the parameters must be determined experimentally. The PI controller consists of proportional and integral term. The proportional

term changes the controller output proportional to the current error value. Large values of proportional term make the system unstable. Large values of proportional term make the system unstable.

The Integral term changes the controller output based on the past values of error. So, the controller attempts to minimize the error by adjusting the controller output. The PI gain values are calculated by using the Cohen and Coon open loop tuning algorithm. PI Controller can expressed by the equation

$$u(t) = k_c e(t) + \frac{1}{T_i} \int_0^t e(t) dt$$

Where

u(t) -The control sign

e (t) -The difference between the current value and the set point.

K_c - The gain for a proportional controller.

T_i - The parameter that scales the integral controller.

t - The time taken for error measurement.

Controller tuning is the process of determining the controller parameters which produce the desired output. Controller tuning allows for optimization of a process and minimizes the error between the variable of the process and its set point .The most common classical controller tuning methods are the Z-N , Cohen-Coon method and Internal Mode Control Tuning.

3.1 Internal Model Control

Internal model control tuning also referred as Lambda tuning method offers a robust alternative tuning aiming for speed. The tuning is very robust meaning that the closed loop will remain stable even if the process characteristics change dramatically. Lambda tuning is a form of internal model control (IMC) that endows a PI controller with the ability to generate smooth, non-oscillatory control efforts when responding to changes in the set point. The IMC based PI parameter tuning formulas are given by following equation

$$k_p = \frac{\tau}{(\lambda + \tau_d)k}$$

$$k_I = \frac{k_p}{\tau}$$

The calculated PI gain parameters can be given as $K_p = 38.106$

$K_I = 0.242$

3.2 Model Reference Adaptive Controller

Adaptive control has always been a successful methodology to control a system with parametric variations. A tuning system of an adaptive control will sense these parametric variations and tune the controller parameters in order to compensate for it. The parametric variation may be due to the disturbance or due to the inherent non-linearity of the system such as conical tank.

In a conical tank the cross section area varies as a function of level which in turn leads to parametric variations. The time constant and gain of the chosen process vary as a function of level. In MRAC reference model describes the performance. The adaptive controller is then designed to force the system (or plant) to behave like the reference model. Model output is compared to the actual output and the difference is used to adjust feedback controller parameters.

MRAC has two loops: an inner loop (or regulator loop) that is an ordinary control loop consisting of the plant and the regulator, and an outer (or adaptation) loop that adjusts the parameters of the regulator in such a way as to drive the error between the model output and plant output to zero, as shown in Fig 2.

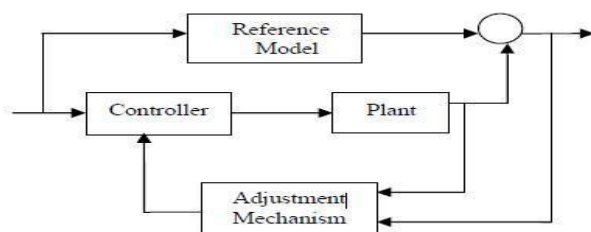

Fig-2: Adaptive control block

3.3 Components of Model Reference Adaptive Controller

Reference Model

It is used to specify the ideal response of the adaptive control system to external command. It should reflect the performance specifications in control tasks. In this paper the critically damped second order system is taken as the reference model

Controller

It is usually parameterized by a number of adjustable parameters. In this paper, two parameters θ_1 and θ_2 are used to define the controller law. The control law is linear in terms of the adjustable parameters (linear parameterization). Adaptive controller design normally requires linear parameterization in order to obtain adaptation mechanism with guaranteed stability and tracking convergence. The values of these control parameters are mainly dependent on adaptation gain. Which in turn changes the control algorithm of adaptation mechanism.

Adaptation Mechanism

It is used to adjust the parameters in the control law. Adaptation law searches for the parameters such that the response of the plant which should be same as the reference model

Controller Algorithm

The block diagram for MRAC tuned PI controller is shown in Fig 3

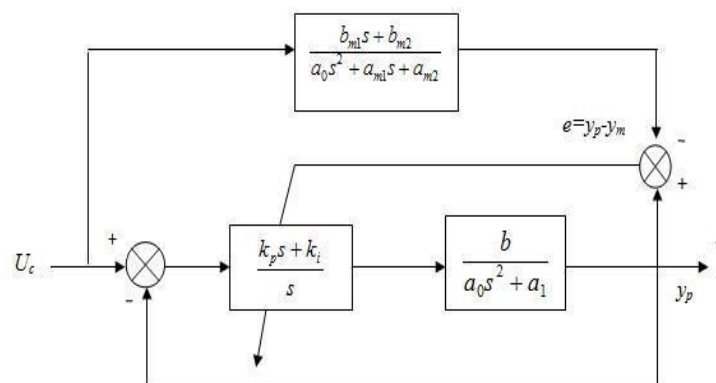

Fig-3: Controller block

4. SIMULATION RESULTS

Closed loop Response of IMC Tuned PI Controller

The lambda tuning rules also called as IMC tuning, offers an alternative tuning aiming for speed. The tuning is very robust meaning that the closed loop will remain stable even if the process characteristics change dramatically. If the set point given as 10 cm, it settles exactly at the set point.

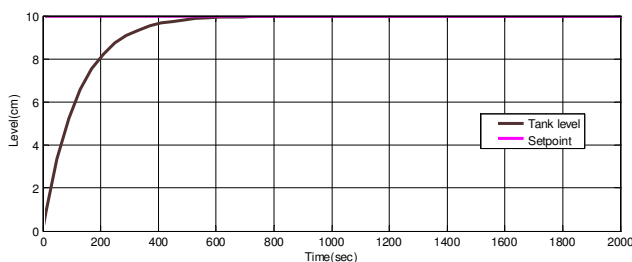

Fig-4: Response of IMC Tuned PI controller

Closed loop Response of MRAC Tuned PI Controller

In MRAC a reference model describes the system's performance. The adaptive controller is then designed to force the system (or plant) to behave like the reference model. Model output is compared to the actual output and the difference is used to adjust feedback controller parameters. The response of the MRAC tuned PI controller is shown in fig 5

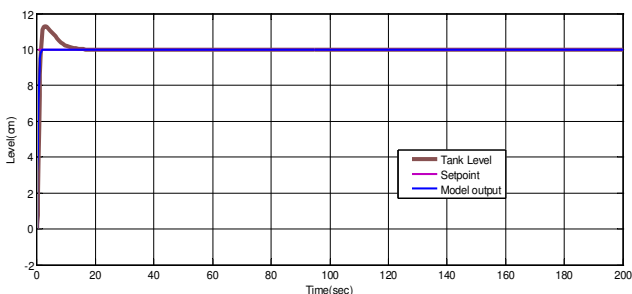

Fig- 5: Response of MRAC Tuned PI controller To Compare the Controller action various parameters such as rise time, peak time, peak overshoot and settling time are taken. Comparison of Z-N, MRAC tuned PI controller is shown in Table

Table-2: Comparative analysis

S.No	Parameters	IMC Tuned PI	MRAC Tuned PI
1	Settlingtime(sec)	600	20
2	Rise time(sec)	400	5
3	Overshoot	0	10
4	Integral Absolute Error	1033	12.57

It is inferred that the Integral Absolute Error is reduced in MRAC when compared to the IMC PI controller. The settling time is also reduced in MRAC compared IMC tuned PI which means it gives the faster response.

5. CONCLUSION

The nonlinearity of the conical tank is analyzed .Conventional PI and MRAC is implemented in MATLAB simulation. IMC tuned PI controller and MRAC Tuned PI controller is implemented in simulation IMC tuned PI Controller are compared with MRAC tuned Controller. MRAC Tuned PI controller gives the better performance.The controlling of nonlinear process is a challenging task. The IMC controllers are designed in such a way that the system is physically reliable. But due to the presence of dead time, the performance of the system is affected. To avoid that advanced control schemes such as Model Reference Adaptive Controller is implemented in simulation.

In future Model Reference Adaptive Controller is to be implemented for Real time to control the Level of Conical Tank system without Piecewise Linearization. Adaptation Gain in MRAC is to be Optimized using Optimization Techniques.

REFERENCES

1. Abhishek Sharma and Nithya Venkatesan (2013), "Comparing PI controller Performance for Non Linear Process Model", International Journal of Engineering Trends and Technology, Vol.4, No.3, pp.242-245.
2. Anand, S., Aswin, V. and Kumar, S.R. (2011), "Simple Tuned Adaptive PI Controller for Conical Tank Process", Recent Advancements in Electrical, Electronics and Control Engineering, pp.263 – 267.
3. Angeline Vijula, D., Devarajan, N., (2014), "Design of Decentralized PI Controller using Model Reference Adaptive Control for Quadruple Tank Process", International Journal of Engineering and Technology, Vol.5, No.6, pp 5057-5066.
4. Bhuvaneshwari, N.S., Uma, G. and Rangaswamy, T.R. (2009), "Adaptive and optimal Control of a Non-Linear Process using Intelligent Controllers", Applied soft computing, Vol.9, No.1, pp.182-19.
5. Boonsrimuang, P., Numsomran, A., Kangwanrat, S., (2009), "Design of PI Controller using MRAC Techniques for Couple-Tank Process", International Science Index, Vol.3, No.11, pp 63-68.
6. Ganesh Ram, A., Abraham Lincoln, S. (2013), "A Model Reference-based Fuzzy Adaptive PI Controller for Nonlinear Level Process System", International Journal of Research and Reviews in Applied Sciences Vol.14, No.2, pp.477-486.
7. George Stephanopoulos (1984) "Chemical Process Control", Prentice-Hall publication, New Jersey, Eastern Economy Edition.
8. Kala, H., Aravind, P. and Valluvan, M. (2013), "Comparative Analysis of different Controller for a Nonlinear Level Control Process" Proceedings of IEEE Conference on Information and Communication Technologies, pp.724-729
9. Kesavan, E. and Rakesh kumar, S. (2013), "PLC based Adaptive PID Control of Non Linear Liquid Tank System using Online Estimation of Linear Parameters by Difference Equations" International Journal of Engineering and Technology, Vol.5, No.2, pp.910-916
10. Marshiana, D. and Thirusakthimurugan, P. (2012), "Design of Ziegler Nichols Tuning Controller for a Non-linear System", Proceedings of International Conference on Computing and Control Engineering, pp.121-124.
11. Nithya, S., Sivakumaran, N., Balasubramanian, T. and Anantharaman, N. (2008), "Model based Controller Design for a Spherical Tank Process in Real Time", International Journal of Simulation, Systems, Science and Technology, Vol. 9, No.3, pp. 247-252.